

Introducing **EZ limo**, the New Linear-Motion System That's Much Easier to Use



EZ limo
easy linear motion





EZ limo

— Easy to use linear motion

*Oriental Motor began by thinking from the user's point of view and a commitment to do whatever it takes to achieve what our users have requested. Oriental Motor then combined a number of advanced functions needed to obtain the high level of easy to use functionality that the **EZ limo** series includes today. Oriental Motor also worked to create a visual design that has never been seen in a factory automation environment. Based on the principles of making a product that was both easy to use and pleasing to look at, Oriental Motor is pleased to introduce the **EZ limo** series of linear motion products.*



E a s y t o U s e

EZlimo: Series Line-Up

- Motorized Linear Slides
 - EZS Series**
 - EZHS Series**
- Motorized Cylinders
 - EZC Series**
 - EZHC Series**
 - EZHP Series**



Index

LIMO

Features	4~5
Functions	6~9
Selection	10~11
Line-Up · Conformance with EC Directives/Safety Standards and CE Marking	12~15
System Configuration	16~19
Motorized Linear Slides	20~35
Motorized Cylinders	36~51
Controller	52~55
Connection Diagrams	56~61
Installation	62~64
Optional Parts	65~73
Linear Motion Products	74~75

Employing Ideals that are Distinctive to Oriental Motor

EZ limo is a linear-motion system that combines Oriental Motor's pledge of "ultimate user-friendliness", "utilization of the latest motor technology", "pursuit of mechanical design excellence" and "consideration for safety and the environment".

Motorized Linear Slides

EZS Series

EZHS Series

Fastest



Motorized Cylinders

EZC Series

EZHC Series

Fastest

EZHP Series

Highest Thrust



Useful

Ultimate User-Friendliness

●Offering a Wide Range of Utilities

Up to 63 motion profiles can be set. The system provides a full range of utilities such as a teaching function, push function, area output function, selection of home detection modes and absolute feedback type. **EZ limo** also supports external pulse input, which means you can combine your existing controller with the **EZ limo** system.

●Pleasant, User-Friendly Operation

An optional teaching pendant facilitates data setting and operation. The LCD monitor is easy to see, and the user-friendly controls ensure pleasant, trouble-free operation.



You can set or edit various data on your personal computer using optional data editing software.

Technical

Incorporating Proprietary Technologies from Oriental Motor, an Industry Leader

●New Closed-Loop Control

The motor part houses a stepping motor with a position feedback device. When a condition presenting the possibility of a misstep is detected, the motor performs closed-loop control, thereby ensuring stable operation.

●Prevention of Hunting at Standstill

Unlike conventional servomotors, the motor used in the **EZ limo** system is free from hunting.

●Low Vibration/Low Noise Even During Low-Speed Operation

The new **EZHS/EZHC/EZHP** series adopts a software-based smooth drive control to suppress vibration and noise even during low-speed operation, such as the return-to-home operation.

Mechanical

Pursuit of Mechanical Design Excellence

●Easy Combination of Multiple Axes

If necessary, such as when palletizing the work, two axes can be combined using an optional dual axis mounting bracket. X-Y configuration (4 patterns) and X-Z configuration (4 patterns) can be implemented with ease.



Installation example:
X-Y configuration



Installation example:
X-Z configuration

●Maintenance-Free for Long-Term Performance

The drive mechanism uses THK's ball screw, while the guide mechanism adopts THK's LM Guide®.

The ball screw employs the QZ™ lubrication system, while the LM Guide® uses the Ball Retainer® to retain the coupled rolling elements. These mechanisms give the system a considerable duration of maintenance-free performance.

* QZ™ lubrication system (THK): High-density fiber net supplies appropriate amounts of oil, thereby preventing oil wastage and reducing environmental burden.

* Ball Retainer®(THK): Individual balls are retained in a manner allowing smooth rotation while preventing contact with adjacent balls. Use of the Ball Retainer® provides long-term, maintenance-free operating conditions and other benefits.

* Ball Retainer and LM Guide are registered trademarks of THK Co., Ltd.

●Thin, Compact Linear Slide

The linear slide is only 31.5 mm high (**EZS4·EZHS4**). The ultra thin body helps save space at the installation site.



Safety

Consideration for Safety and the Environment

●Environmentally Friendly

The **EZ limo** system is constructed from carefully selected parts that exert a minimum burden on the environment.

●UL/CSA Standards

The **EZHS/EZHC/EZHP** series adopt a motor and controller certified by UL/CSA standards.

●CE Marking

All **EZ limo** products bear the CE mark to indicate their conformance with the Low-Voltage and EMC directives.

* See "Conformance with EC Directives" on p.13 & p.15 for details.



EZ limo : The Ultimate Combination of User-Friendliness, High Reliability and High Functionality

Common

Space-Saving Cable Outlet Orientation

The cable outlet is facing downward, which contributes to the overall space savings by reducing the space needed to wire the cables.



EZS EZHS

Positioning Pinholes on the Table

These holes help maintain positional repeatability when the work must be removed and then installed again for the purpose of maintenance, etc.

EZS EZHS

Stainless Sheet

The mechanical parts of the linear slide are covered with a stainless sheet to keep out foreign particles.
(The stainless sheet is also available as a spare part.)

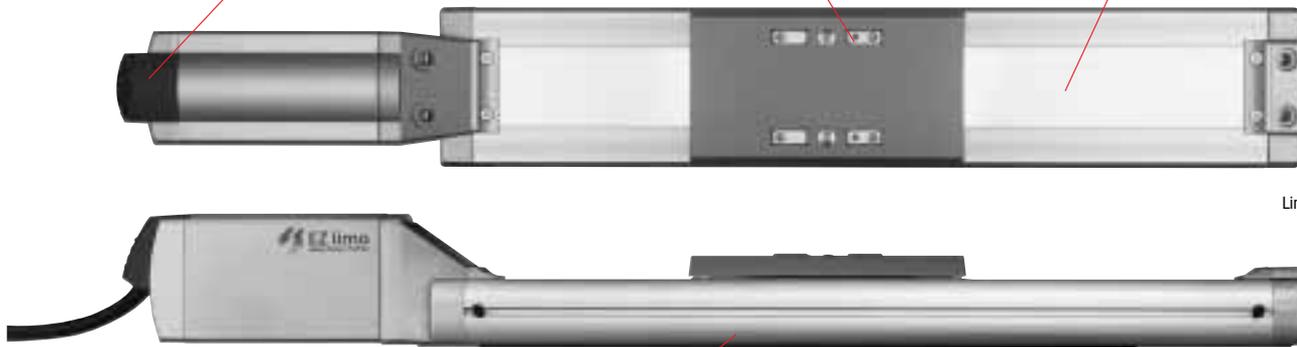

Linear slide height
31.5 mm
EZS4
EZHS4

Common

Drive method : THK's ball screw

(The QZ™ lubrication system provides a considerable duration of maintenance-free performance.)

EZS EZHS

Guide mechanism: THK's LM Guide®

(Ball Retainer® provides long-term, maintenance-free operating conditions.)

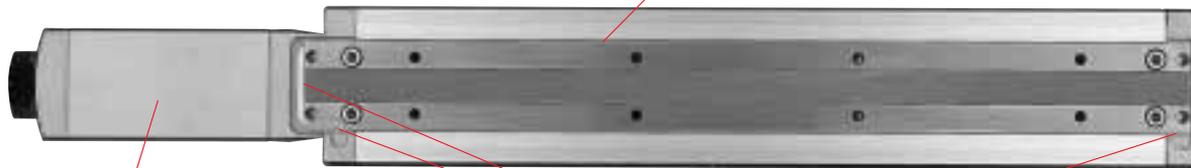

Common

Easy Connection

A connector provides a simple, one-touch connection to the controller.
A power cable is also supplied for ease of connection.

EZS EZHS

Mounting Reference Surface

These surfaces help maintain positional repeatability when the linear slide must be removed and then installed again for the purpose of maintenance, etc.

Common

Easy Installation

Both the mechanical parts and controller can be installed easily.

Linear Slide: The linear slide body can be affixed directly from the top and bottom with screws.
(EZS3 and EZHS3 can be affixed only from the bottom.)

Cylinder: The cylinder can be installed through the dedicated mounting holes, or via a flange connection using an optional mounting bracket.

Controller: The EZS/EZC series controllers can be installed with mounting screws or using a DIN rail. The EZHS/EZHC/EZHP series controllers come with dedicated mounting brackets.

* See p.62 to p.64 for details on the installation.

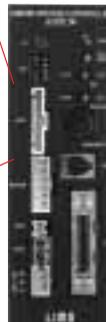

Common

Real-Time Monitoring

Information such as set data, current position and I/O status can be monitored in real time using an optional teaching pendant (sold separately).



Choice of Incremental Type or Absolute Type Feedback Common

As long as power is supplied, the **EZ limo** system can proceed to the next operation without executing home detection, even given the occurrence of an overload or emergency stop error.

Choose the incremental type if you want to execute home detection each time the power is turned on. The absolute type would be your choice if you want to start operation from the current position rather than the home position, when the power is turned on.

Absolute Type

The absolute type allows the movement of the table or rod to be followed and backed up, even when the power is cut off.

EZS/EZC Series

Two types of backup modes are available. Select the mode that best suits your application.

- Standard backup — Provides a longer backup period
- Optional backup — Provides better speed-follow-up capability

EZHS/EZHC/EZHP Series

These models provide a long backup period of around 15 days (approx. 360 hours).

Teaching Function Common

You can move the table to a desired position manually or by using the teaching pendant and store that position.

Direct Teaching:

Turn off the excitation of the motor and move the table or rod manually to the target position, then store that position in the motion profile.

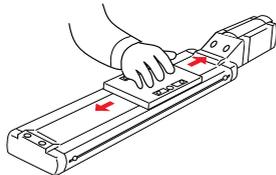

Direct teaching

Remote Teaching:

Use the keys on the teaching pendant to move the table or rod to the target position, then store that position in the motion profile.

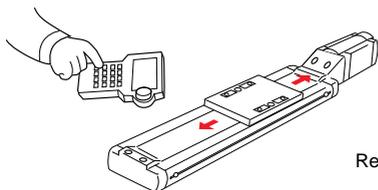

Remote teaching

Choice of Home Detection Methods Common

You can choose the sensorless mode if you want to simplify the mechanical layout, or the sensor mode if you want to use sensors to detect home.

Sensorless Home Detection

Home detection is performed without the use of a home sensor. The home position can be adjusted. For the linear slides, the direction of home detection can also be changed.

Home Detection Using Sensors

Home detection is performed using home sensors. The sensors are available as options. (See p. 68 for the sensor set.)

Operation Using External Pulse Input Common

The **EZ limo** can be combined with your existing controller to serve as a driver.

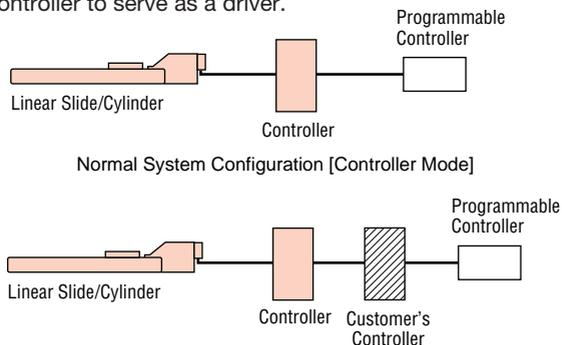

When Combined with the Customer's Controller [Driver Mode]

	Controller Mode	Driver Mode
Push Function	●	×
Teaching Function	●	×
Monitoring Function	●	×
Pause Function *1	●	×
Area Output Function	●	×
Absolute Type	●	●*2
Sensorless Home Detection	●	×

● = Available × = Not available

Notes:

- Certain functions cannot be used in the driver mode.
- Provide HOME, +LS and -LS sensors (optional) and connect them to the controller you want to use.

*1 Only for **EZS** and **EZC** Series

*2 Only for **EZHS**, **EZHC** and **EZHP** Series

Push Function EZC EZHC EZHP

The rod can be held in a state of being pushed against the work or similar object, as with an air cylinder.

The force used to push the work (push force) can be changed. The **EZHC/EZHP** series handles up to 63 push width/force profiles.

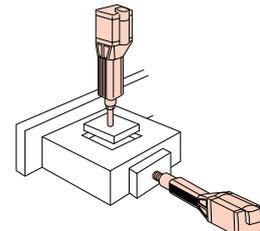
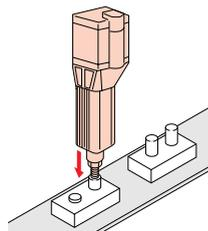

Area Output Function

Common

A signal is output when the linear slide table or cylinder rod enters a set range during operation.

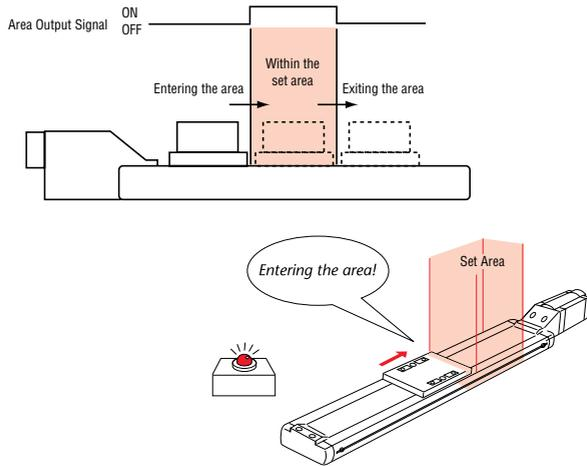

Easy Data Editing

EZS EZC

You can set and edit various data on a personal computer (PC) using the optional data editing software. The software comes with a PC interface cable (five meters in length) used to connect the controller and PC. The software also provides various monitoring functions.

* See p.16 and p.65 for details.

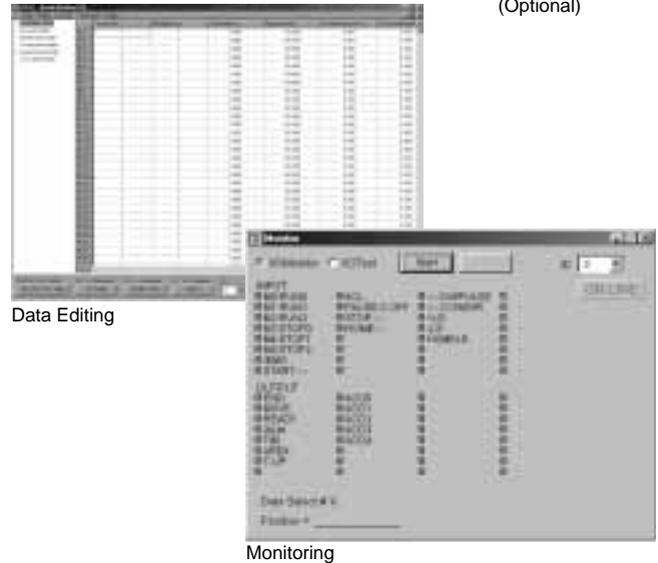
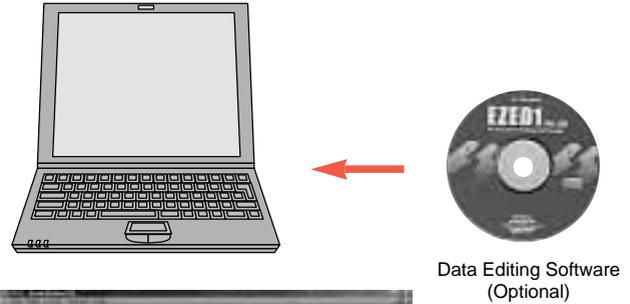

Pause Function

EZS EZC

The linear slide/cylinder can be stopped temporarily during operation, using an external signal. When the pause input signal (PAUSE) is turned ON, the linear slide/cylinder decelerates to a stop. When the START signal is turned ON again after the (PAUSE) signal is turned OFF, the linear slide/cylinder resumes operation from the position at which it had stopped.

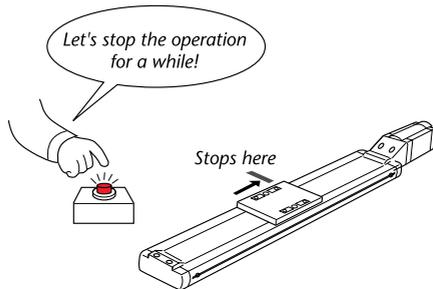

Connection of Multiple Axes

Common

A maximum of 16 controllers can be connected, with data set separately for each of the controllers. There is no need to connect the teaching pendant to each of the controllers.

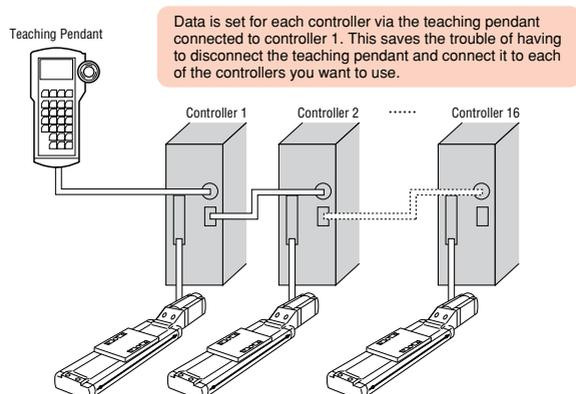

Multifunction Controller (Stored-Data Type)

● A Maximum of 63 Motion Profiles

Common

Up to 63 motion profiles can be set by the controller.

● Two Motion Profile Setting Modes: Absolute Mode and Incremental Mode

Common

You can set motion profiles in the absolute mode or incremental mode, depending on your preferred movement of the equipment.

Absolute Mode (Absolute-Position Specification) :

Each position is set as the absolute position with respect to the reference point. This is suitable when you want to move the work directly from an arbitrary position to the specified position.

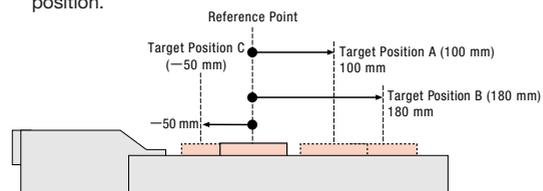

Incremental Mode (Relative-Position Specification) :

Each position is relative, being set as an amount of travel from the current position or another target position for the work. This is suitable in a regular feed or other operation where the same pattern is used repeatedly.

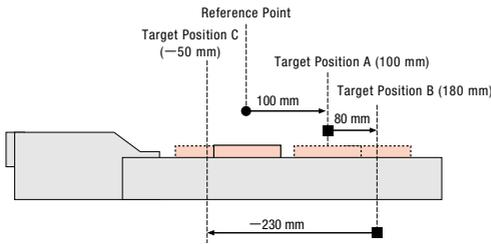

Simple Unit Setting Common

Travel amount, operating speed and acceleration/deceleration can be set directly as mm, mm/s and m/s² values, respectively. There is no need for pulse conversion, which allows for more efficient operation of a linear-motion product.

Continuous Operation via External Signal EZHS EZHC EZHP

Continuous operation can be performed while an external signal (FWD, RVS) is ON. This mode is ideal when you want to move the work via external control without using the teaching pendant.

Output of Current Position and Error Code EZHS EZHC EZHP

The current position, error code and certain other data can be output to an external device.

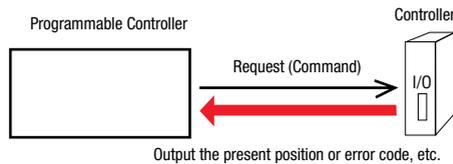

Table/Rod Position Monitor EZHS EZHC EZHP

A counter or similar device can be connected to monitor the position of the linear slide table or cylinder rod using phase-A/B pulse signal outputs.

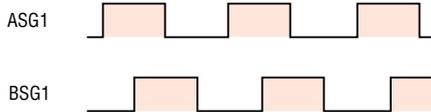

(When the slider table or cylinder rod is moving to the counter-motor side)

Notes:

- The phase difference between A and B is 90° electrical.
- The pulse output accuracy is within ±0.01 mm.
- Pulse output is subject to a maximum delay of 1 ms with respect to the actual movement of the linear slide table or cylinder rod.
- Use this function to check the stop position.
- Pulse output is possible at up to the maximum operating speed of each series. When counting the number of pulses, use a frequency counter that can count frequencies of at least twice the frequency level of the applicable maximum speed.

- Maximum speed and frequency
EZHS Series : 800 mm/s (80 kHz)
EZHC Series : 600 mm/s (60 kHz)
EZHP Series : 300 mm/s (60 kHz)

- When a line-driver output is used, connect a 150 Ω terminal resistor between the line-receiver inputs.
- When an open-collector output is used, keep the cable length to 2 m or shorter. With an open-collector output, the output waveform changes depending on the load condition. Check the operation of the connected equipment.

Two Data Execution Modes: Selective Positioning and Sequential Positioning Common

Selective positioning mode:

The set data can be selected at random.

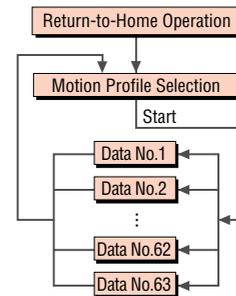

Sequential positioning mode:

Positioning operations are performed sequentially from the desired data.

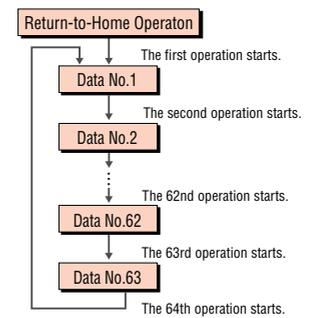

Separate Acceleration and Deceleration Settings Common

Acceleration and deceleration can be set separately for each motion profile. This feature is useful in a quick acceleration/slow deceleration operation where the motor rises quickly and then decelerates slowly to a stop. [The opposite pattern (slow acceleration/quick deceleration) is also supported.]

EZS/EZC Series: Each motion profile has its own acceleration and deceleration settings.

EZHS/EZHC/EZHP Series: One common acceleration and deceleration setting for all motion profiles

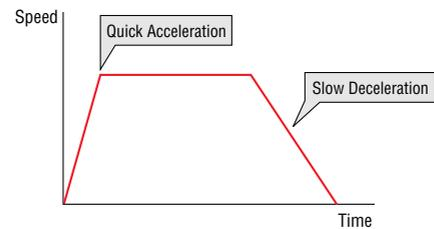

Linked Operation Common

Up to 63 motion profiles (for **EZS/EZC** Series) or 4 motion profiles (for **EZHS/EZHC/EZHP** Series) can be linked, thereby allowing the motor to change speeds without stopping.

Note: The motion profiles must create a motion in the same direction in order to be linked.

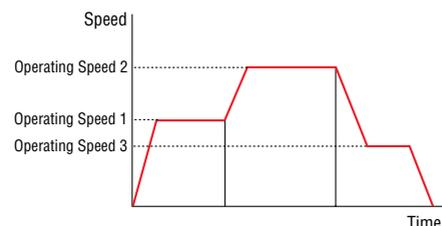

To select an **EZ limo** product that best suits your application, check the required specifications using the following procedure:

[1] Check the required operation.

[2] Check the direction of installation.

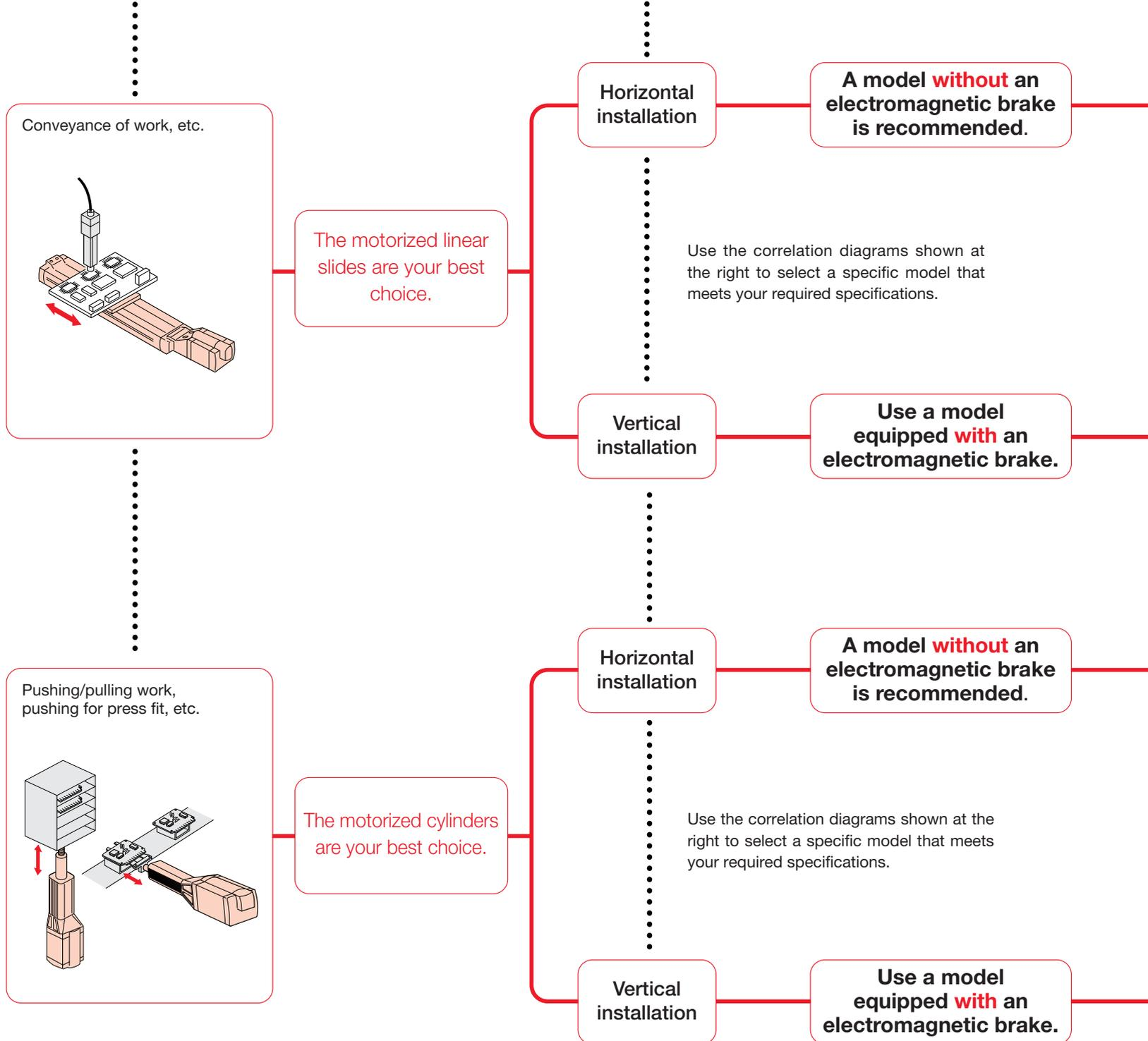

Correlation of Speed and Load Weight for Linear Slide Horizontal Direction

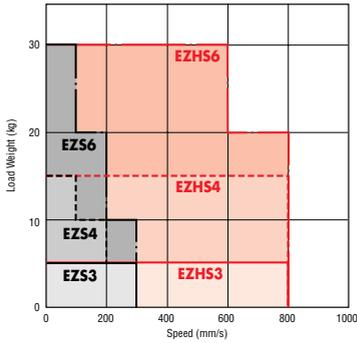

Correlation of Speed and Load Weight for Linear Slide Vertical Direction

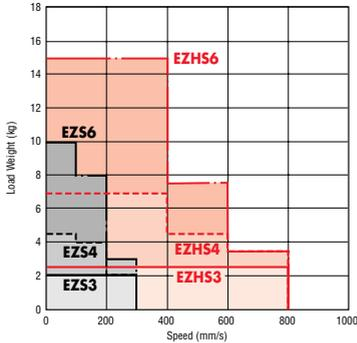

Correlation of Speed and Thrust Force for Cylinder Horizontal Direction

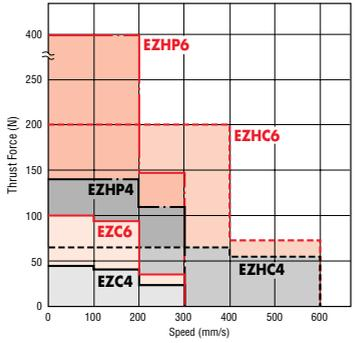

Correlation of Speed and Thrust Force for Cylinder Vertical Direction

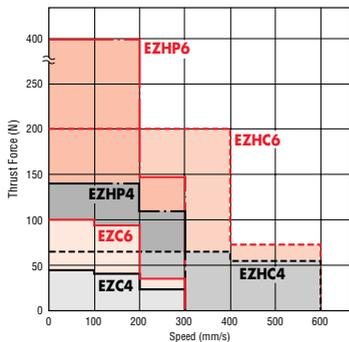

Correlation of Speed and Load Weight for Cylinder Vertical Direction

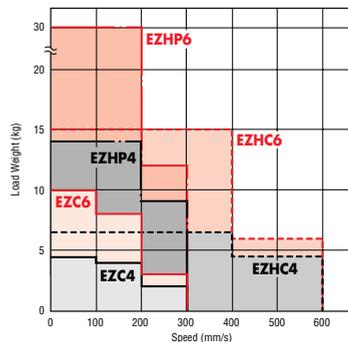

Motorized Linear Slides EZS Series



EZHS Series

Line-Up Page 12~15

EZS Series Specifications & Characteristics Page 24~29

EZHS Series Specifications & Characteristics ... Page 30~35

Note: If the object to be installed to the linear slides has a large overhung from the center of the table, consider the length of overhung.
(See the allowable overhung lengths specified on p. 24 to p. 34.)

Motorized Cylinders EZC Series



EZHC Series EZHP Series

Line-Up Page 12~15

EZC Series Specifications & Characteristics Page 40~43

EZHC Series Specifications & Characteristics ... Page 44~47

EZHP Series Specifications & Characteristics ... Page 48~51

Motorized Linear Slides

EZS Series

Model	Power Supply	Electromagnetic Brake	Type	Stroke mm	Maximum Speed mm/s	Max. Transportable Mass kg		Max. Thrust Force N	CE Marking	Page
						Horizontal Direction	Vertical Direction			
EZS3-□CI	24 VDC	Not equipped	Incremental	50 100 150 200 250 300 400 500	300	5	—	23	○	24
EZS3-□CA			Absolute							
EZS3-□MCI		Equipped	Incremental		300	5	2	23		
EZS3-□MCA			Absolute							
EZS4-□CI		Not equipped	Incremental		100	15	—	45		
EZS4-□CA			Absolute		200	10	—	40		
EZS4-□MCI		Equipped	Incremental	300	5	—	23			
EZS4-□MCA			Absolute	100	15	4.5	45			
EZS6-□CI		Not equipped	Incremental	200	10	4	40			
EZS6-□CA			Absolute	300	5	2	23			
EZS6-□MCI		Equipped	Incremental	100	30	—	100			
EZS6-□MCA			Absolute	150	20	—	94			
EZS6-□MCI	Equipped	Incremental	200	10	—	35				
EZS6-□MCA		Absolute	250	100	30	10	100			
EZS6-□MCI	Equipped	Incremental	300	20	8	94				
EZS6-□MCA		Absolute	400	10	3	35				
EZS6-□MCI	Equipped	Incremental	500	300	10	3	35			
EZS6-□MCA		Absolute	500	300	10	3	35			

*The box in the model name represents the code for stroke length.

Motorized Cylinders

EZC Series

Model	Power Supply	Electromagnetic Brake	Type	Stroke mm	Maximum Speed mm/s	Max. Transportable Mass kg		Max. Thrust Force N	CE Marking	Page
						Horizontal Direction	Vertical Direction			
EZC4-□CI	24 VDC	Not equipped	Incremental	50 100 200 300	100	—	—	45	○	40
EZC4-□CA			Absolute		200	—	—	40		
EZC4-□MCI		Equipped	Incremental		300	—	—	23		
EZC4-□MCA			Absolute		100	—	4.5	45		
EZC6-□CI		Not equipped	Incremental		200	—	4	40		
EZC6-□CA			Absolute		300	—	2	23		
EZC6-□MCI		Equipped	Incremental	100	—	—	100			
EZC6-□MCA			Absolute	200	—	—	94			
EZC6-□MCI		Equipped	Incremental	300	—	—	35			
EZC6-□MCA			Absolute	100	—	10	100			
EZC6-□MCI		Equipped	Incremental	200	—	8	94			
EZC6-□MCA			Absolute	300	—	3	35			

*The box in the model name represents the code for stroke length.

■ Conformance with EC Directives (EVS and EZC series)

The linear slides, cylinders, controllers and teaching pendant bear the CE mark to indicate their conformance with the EMC directives.

● Compliance Conditions

- Incorporation in equipment
- Overvoltage Category: I
- Pollution Degree: Class 2
- Class III equipment

● EMC Directives (89/336/EEC, 92/31/EEC)

See the instructions in the "EVS/EZC Series Controller User Manual" for the installation and wiring methods.

◇ Applicable Standards

- EMI Emission Tests: EN 50081-2
- Radiated Emission Test: EN 55011
- EMS Immunity Tests: EN 61000-6-2
- Radiation Field Immunity Test: IEC 61000-4-3
- Electrostatic Discharge Immunity Test: IEC 61000-4-2
- Fast Transient/Burst Immunity Test: IEC 61000-4-4
- Conductive Noise Immunity Test: IEC 61000-4-6

● Emergency Stop

The emergency stop function cuts off the motor current, leaving the motor in a free state.

◇ Emergency Stop Function

The stop action actuated by the emergency stop switch or EMG input conforms to "Stop Category 0 (non-controlled stop)" under EN 60204-1.

◇ Emergency Stop Circuit

The safety parts in the emergency stop circuit are selected in accordance with the requirements of EN 954-1, category 1.



Motorized Linear Slides **EZHS** Series

Model	Power Supply Single-Phase	Electromagnetic Brake	Type	Stroke mm	Maximum Speed mm/s	Max. Transportable Mass kg		Max. Thrust Force N	CE Marking	Page
						Horizontal Direction	Vertical Direction			
EZHS3A-□I	100-115V	Not equipped	Incremental	50 100 150 200	800	5	—	30	×	30
EZHS3A-□A			Absolute							
EZHS3A-□MI		Equipped	Incremental							
EZHS3A-□MA			Absolute							
EZHS4A-□I		Not equipped	Incremental	250	400	15	—	70		32
EZHS4A-□A				Absolute						
EZHS4A-□MI		Equipped	Incremental	300	600	15	—	55		
EZHS4A-□MA				Absolute						
EZHS4A-□MI	Equipped	Incremental	400	800	15	7	70			
EZHS4A-□MA			Absolute							
EZHS4A-□MA	Equipped	Incremental	500	800	15	4.5	55			
EZHS4A-□MA			Absolute							
EZHS6A-□I	100-115V	Not equipped	Incremental	100 150	400 600 800	30 30 20	— — —	184 92 50	○	34
EZHS6C-□I	200-230V		Absolute							
EZHS6A-□A	100-115V		Absolute							
EZHS6C-□A	200-230V	Equipped	Incremental	200 250 300 400 500	400 600 800	30 30 20	15 7.5 3.5	184 92 50		
EZHS6A-□MI	100-115V									
EZHS6C-□MI	200-230V		Absolute							
EZHS6A-□MA	100-115V		Absolute							
EZHS6C-□MA	200-230V	Absolute								

*The box in the model name represents the code for stroke length.

Motorized Cylinders **EZHC** Series

Model	Power Supply Single-Phase	Electromagnetic Brake	Type	Stroke mm	Maximum Speed mm/s	Max. Transportable Mass kg		Max. Thrust Force N	CE Marking	Page
						Horizontal Direction	Vertical Direction			
EZHC4A-□I	100-115V	Not equipped	Incremental	50 100 200 300	400 600	— —	— —	65 55	×	44
EZHC4A-□A			Absolute							
EZHC4A-□MI		Equipped	Incremental							
EZHC4A-□MA			Absolute							
EZHC6A-□I	100-115V	Not equipped	Incremental	50 100 200 300	400 600	— —	— —	200 73	○	46
EZHC6C-□I	200-230V		Absolute							
EZHC6A-□A	100-115V		Absolute							
EZHC6C-□A	200-230V	Equipped	Incremental	400 600	— —	15 6	200 73			
EZHC6A-□MI	100-115V							Absolute		
EZHC6C-□MI	200-230V		Absolute							
EZHC6A-□MA	100-115V		Absolute							
EZHC6C-□MA	200-230V	Absolute								

*The box in the model name represents the code for stroke length.

Motorized Cylinders **EZHP** Series

Model	Power Supply Single-Phase	Electromagnetic Brake	Type	Stroke mm	Maximum Speed mm/s	Max. Transportable Mass kg		Max. Thrust Force N	CE Marking	Page
						Horizontal Direction	Vertical Direction			
EZHP4A-□I	100-115V	Not equipped	Incremental	50 100 200 300	200 300	— —	— —	140 110	×	48
EZHP4A-□A			Absolute							
EZHP4A-□MI		Equipped	Incremental							
EZHP4A-□MA			Absolute							
EZHP6A-□I	100-115V	Not equipped	Incremental	50 100 200 300	200 300	— —	— —	400 147	○	50
EZHP6C-□I	200-230V		Absolute							
EZHP6A-□A	100-115V		Absolute							
EZHP6C-□A	200-230V	Equipped	Incremental	200 300	— —	30 12	400 147			
EZHP6A-□MI	100-115V							Absolute		
EZHP6C-□MI	200-230V		Absolute							
EZHP6A-□MA	100-115V		Absolute							
EZHP6C-□MA	200-230V	Absolute								

*The box in the model name represents the code for stroke length.



■ Safety Standards and CE Marking (EZHS/EZHC/EZHP series)

● UL/CSA Standards

The **EZHS/EZHC/EZHP** series adopt a motor and controller certified by the UL/CSA standards.

The motors and controllers are certified under the model names listed below.

Model	Certified Products	Standards	Certification Body	File No.
EZHS3A -□□	Motor (Built into linear slide/cylinder)	EZHM46AA	UL 1004, UL 2111	UL E64199
EZHS4A -□□		EZHM46MA *2		
EZHC4A -□□	Controller	EZMC13I-A	UL 508C *1 CSA C22.2 No.14	UL E171462
EZHP4A -□□		EZMC13A-A		
EZHS6 □□□□	Motor (Built into linear slide/cylinder)	EZHM66A	UL 1004, UL 2111 CSA C22.2 No.100 CSA C22.2 No.77	UL E64199
EZHC6 □□□□		EZHM66MA *2		
EZHP6 □□□□		EZHM66AC *2 *3		
		EZHM66MC *2 *3		
	Controller	EZMC24I-A EZMC24A-A EZMC12I-C EZMC12A-C	UL 508C *1 CSA C22.2 No.14	UL E171462

*1 For UL standard (UL 508C), the product is recognized for the condition of Maximum Surrounding Air Temperature 40°C.

*2 With electromagnetic brake

*3 200 VAC input

- The teaching pendant is not certified by the UL standards.

● CE Marking

Product	CE Marking
Linear slide	Low Voltage directive
Controller	EMC directive

The EMC value changes according to the wiring and layout. Therefore, the final EMC level must be checked with the motor/driver incorporated in the user's equipment.

If you require EMC data of Linear Slides or Controllers, please contact your nearest Oriental Motor office.

◇ Machinery Directive (98/37/EC)

The linear slides, cylinders, controllers and teaching pendants are designed and manufactured for use in general industrial equipment as an internal component, and therefore need not comply with the Machinery Directive. However, each product has been evaluated under the following standards to ensure proper operation:

EN 292-1, EN 292-2, EN 954-1, EN 418, EN 60204-1

• Emergency Stop Function

The emergency stop button of the teaching pendant uses an EN-certified product. See page 58 for a connection example that conforms to Stop Category 0 (non-controlled stop) under EN 60204-1.

• Emergency Stop Circuit

The safety parts in the emergency stop circuit are selected in accordance with the requirements of EN 954-1.

■ If you already have a teaching pendant;

Please check its conformance to EC Directives on the nameplate attached on the back of the teaching pendant.

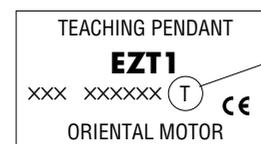

T : Conforming to the Low-Voltage and EMC Directives

J : Conforming to only the EMC Directives

If the nameplate on your teaching pendant shows "J" and your application requires conformance to the Low-Voltage Directives, purchase a new teaching pendant that ensures the required conformance.

■ EZS Series · EZC Series

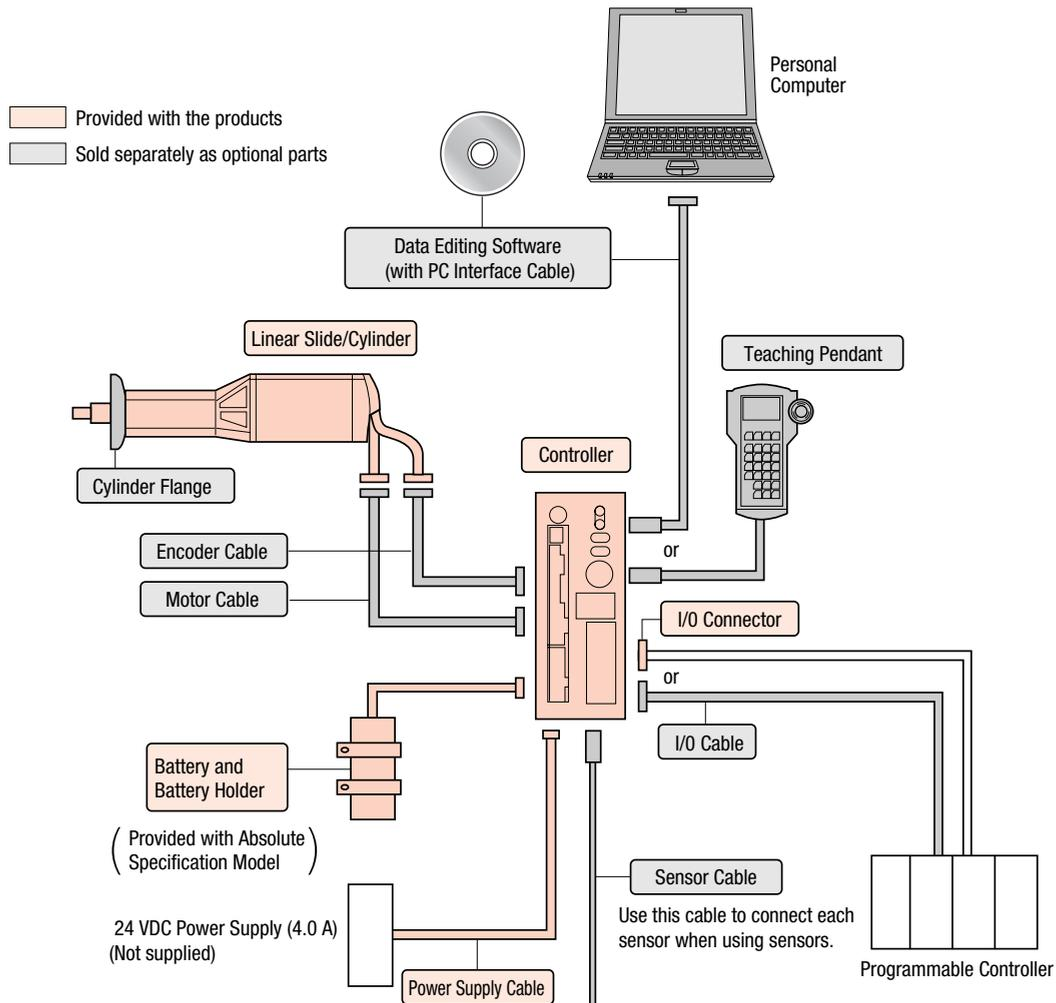

■ Optional Parts (sold separately)

- EZS For use with the **EZS** series
- EZC For use with the **EZC** series

● Teaching Pendant EZS EZC ————— P.65

The teaching pendant allows you to set and execute motion profiles already stored, as well as to monitor the set data, current position and I/O status in real time.



● Data Editing Software EZS EZC ————— P.65

With this software you can set and edit various data on a PC. It comes with a PC interface cable for connecting the controller and PC. The software also provides various monitoring functions.



● **Cable Set** — **EZS** **EZC** — P.66

A set of dedicated cables is used to connect the **EZ limo** linear slide/cylinder with the controller. The cable set consists of a motor cable and an encoder cable. The cable length can be selected from 2 m, 5 m and 10 m. Each of the cables can be purchased individually.



Motor cable



Encoder cable

● **Controller Link Cable** — **EZS** **EZC** — P.67

Use this dedicated cable to link the **EZ limo** controllers. A maximum of 16 controllers can be connected, with data set separately for each of the controllers.

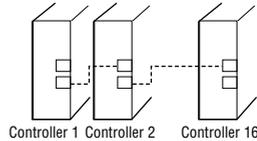

● **I/O Cable** — **EZS** **EZC** — P.67

This cable is used exclusively for connection between the **EZ limo** controller and the host controller. A half-pitch connector allowing one-touch connection to the controller is attached at one end of the flat cable.



● **Sensor Cable** — **EZS** **EZC** — P.67

Use this cable to connect each sensor used in the controller mode to the controller.



● **Sensor Set** — **EZS** **EZC** — P.68

These sensors can be used in the controller mode or driver mode. The sensor set comes with the necessary mounting hardware.



● **Dual Axis Mounting Bracket** — **EZS** — P.69

This dual axis mounting bracket allows easy installation of a pair of axes (**EZS6/EZS4** linear slides). Various types of brackets are available to support combinations of X-Y and X-Z axes.

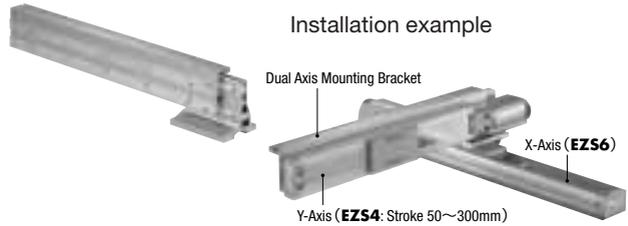

● **Cable Holder** — **EZS** — P.73

This low-noise cable holder protects and guides cables in multi-axis configurations. It can be easily installed on a dual axis mounting bracket using the supplied brackets.

Installation example



● **Cylinder Flange** — **EZC** — P.73

This special mounting bracket is used to install the cylinder from the body side. The flange comes with the mounting screws for affixing the cylinder to the flange. (The customer must provide the mounting screws for affixing the flange to the equipment.)



● **DIN Rail Mounting Plate** — **EZS** **EZC** — P.73

This plate is used to install the **EZ limo** controller to a DIN rail. The plate comes with the mounting screws.

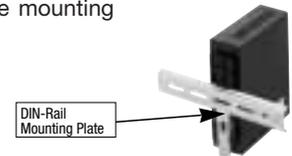

The following spare parts are also available:

● **Stainless Sheet (for linear slide)**
— **EZS** — P.73

● **Battery (for absolute type)**
— **EZS** **EZC** — P.73



* Battery holder not supplied with a spare battery

■ EZHS Series • EZHC Series • EZHP Series

- Provided with the products
- Sold separately as optional parts

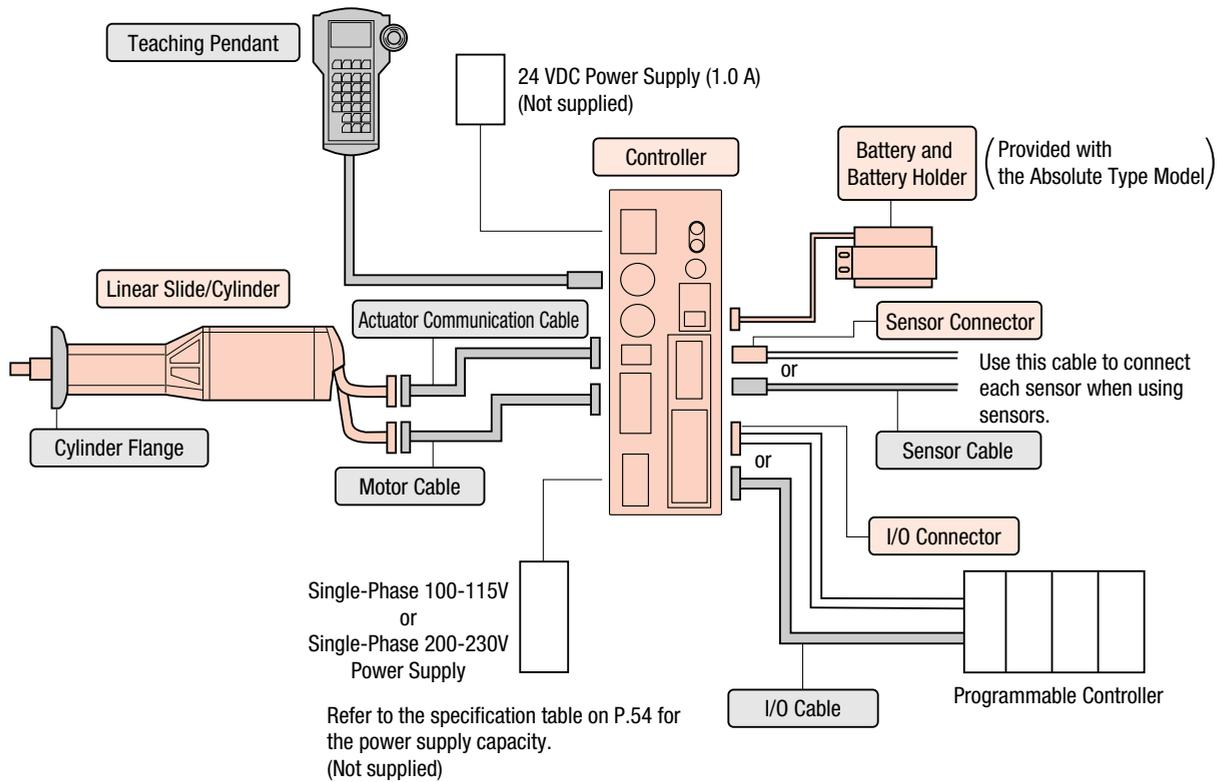

■ Optional Parts (sold separately)

- EZHS** For use with the **EZHS** series
- EZHC** For use with the **EZHC** series
- EZHP** For use with the **EZHP** series

● Teaching Pendant — **EZHS** **EZHC** **EZHP** — P.65

The teaching pendant allows you to set and execute motion profiles already stored, as well as to monitor the set data, current position and I/O status in real time.



● Cable Set — **EZHS** **EZHC** **EZHP** — P.66

A set of dedicated cables is used to connect the **EZ limo** linear slide/cylinder with the controller. The cable set consists of a motor cable and an actuator communication cable. The cable length can be selected from 2 m, 5 m and 10 m. Each of the cables can be purchased individually. Flexible cables are also available.



Motor cable



Actuator communication cable

● **Controller Link Cable** — **EZHS EZHC EZHP** — P.67

Use this dedicated cable to link the **EZ limo** controllers. A maximum of 16 controllers can be connected, with data set separately for each of the controllers.



● **I/O Cable** — **EZHS EZHC EZHP** — P.67

This cable is used exclusively for connection between the **EZ limo** controller and the host controller. A half-pitch connector allowing one-touch connection to the controller is attached at one end of the flat cable.



● **Sensor Cable** — **EZHS EZHC EZHP** — P.67

Use this cable to connect each sensor used in the controller mode to the controller.



● **Sensor Set** — **EZHS EZHC EZHP** — P.68

These sensors can be used in the controller mode or driver mode. The sensor set comes with the necessary mounting hardware.

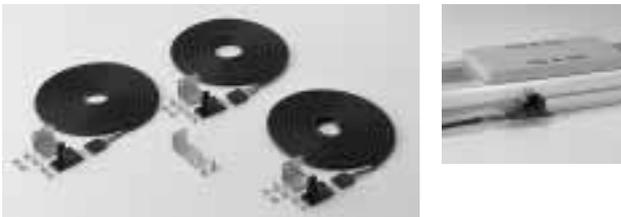

● **Dual Axis Mounting Bracket** — **EZHS** — P.69

This dual axis mounting bracket allows easy installation of a pair of axes (**EZH56/EZH54** linear slides). Various types of brackets are available to support combinations of X-Y and X-Z axes.



● **Cable Holder** — **EZHS** — P.73

This low-noise cable holder protects and guides cables in multi-axis configurations. It can be easily installed on a dual axis mounting bracket using the supplied brackets.

Installation example



● **Cylinder Flange** — **EZHC EZHP** — P.73

This special mounting bracket is used to install the cylinder from the body side. The flange comes with the mounting screws for affixing the cylinder to the flange. (The customer must provide the mounting screws for affixing the flange to the equipment.)



The following spare parts are also available:

● **Stainless Sheet (for linear slide)** — **EZHS** — P.73

● **Battery (for absolute type)** — **EZHS EZHC EZHP** — P.73

* Battery holder not supplied with a spare battery



EZS Series
EZHS Series

EZS Series

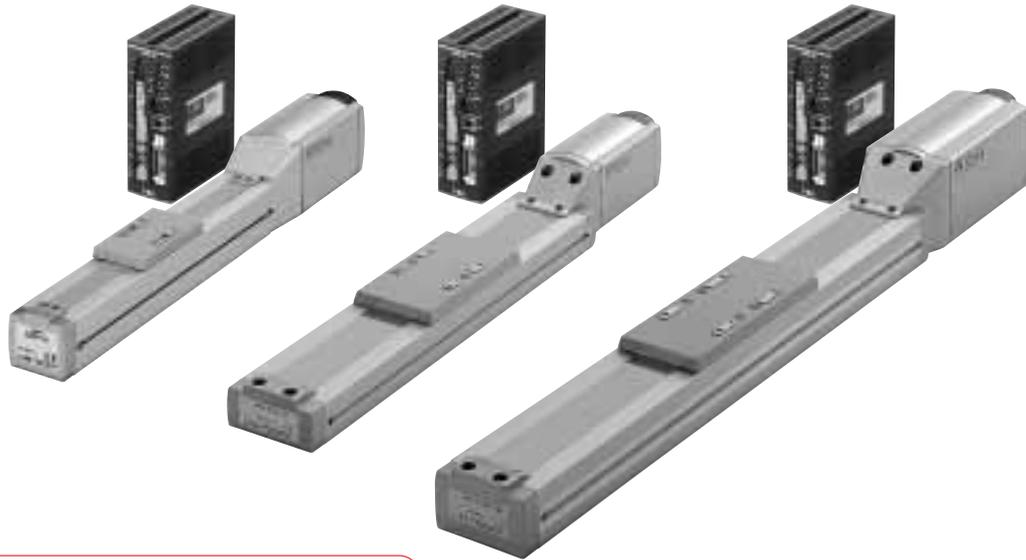

Names and Functions of the Linear Slide



Cable

The cable outlet is facing downward, which contributes to the overall space savings by reducing the space needed to wire the cables.

Stainless Sheet

The mechanical parts of the linear slide are covered with stainless sheet to keep out foreign particles.

Mounting Hole
(Except for EZS3 and EZHS3)

Table

Positioning Pinhole

Mounting Hole
(Except for EZS3 and EZHS3)

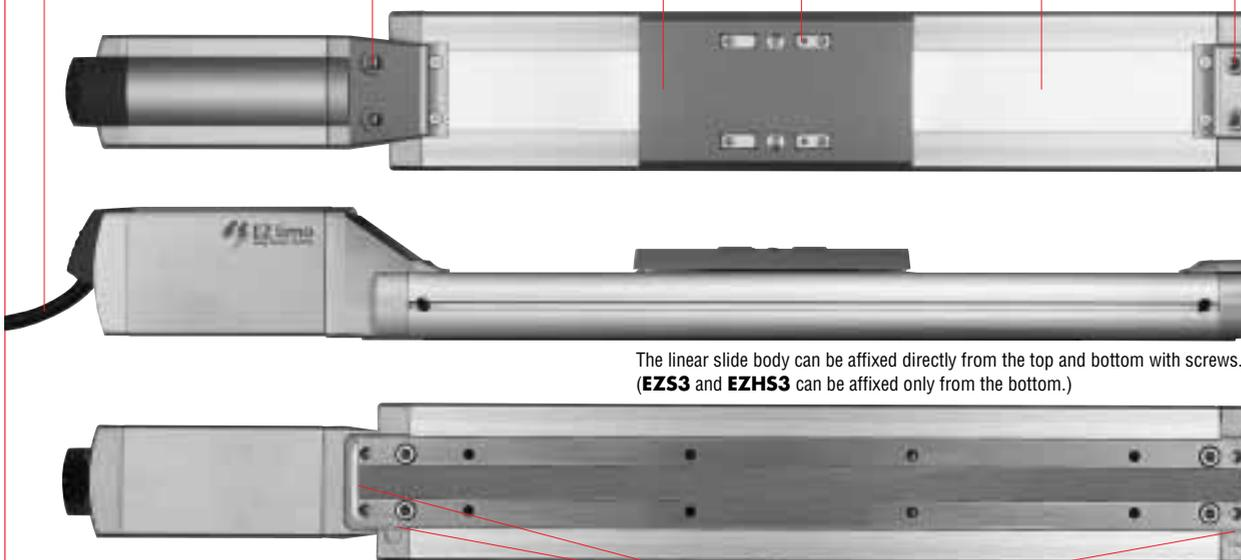

The linear slide body can be affixed directly from the top and bottom with screws. (EZS3 and EZHS3 can be affixed only from the bottom.)

Mounting Reference Surface

EZHS Series

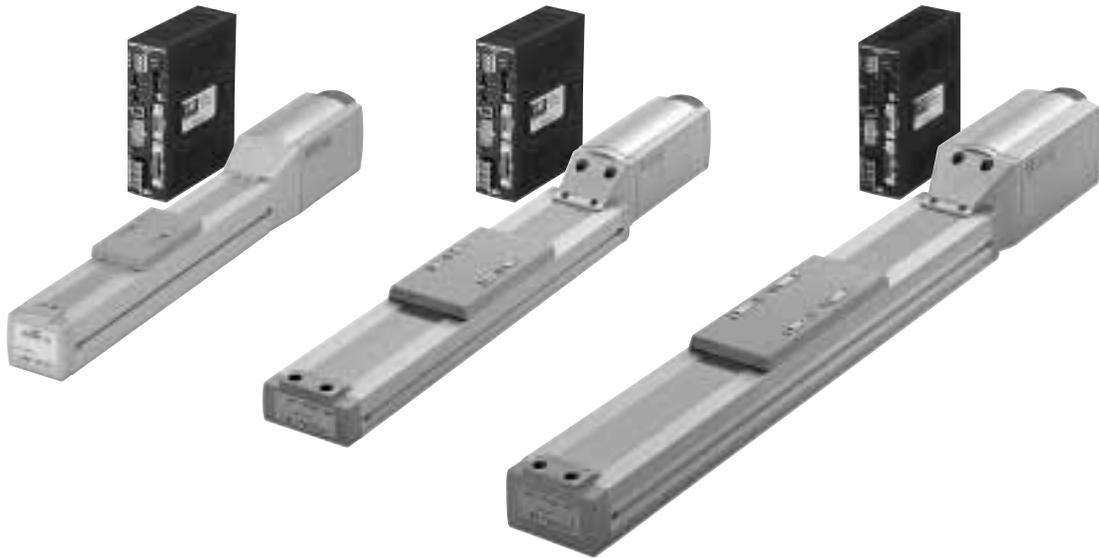

Motorized Linear Slide Speed – Load Weight Characteristics

EZS3/EZHS3

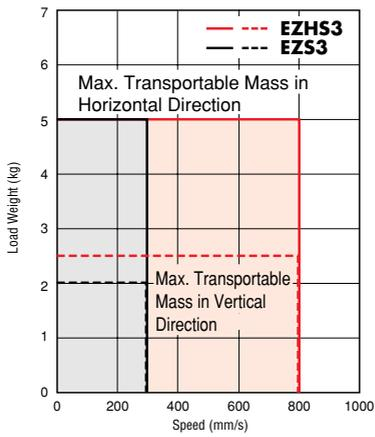

EZS4/EZHS4

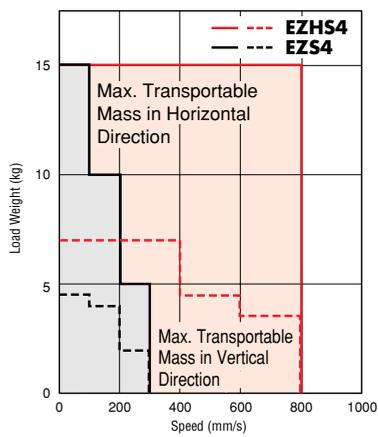

EZS6/EZHS6

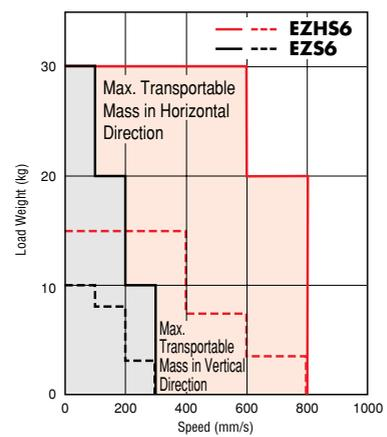

■ Models

●EZS Series

◇ Incremental Type

Without Electromagnetic Brake 24 VDC Input

Stroke	Model		
50mm	EZS3-05CI	EZS4-05CI	—
100mm	EZS3-10CI	EZS4-10CI	EZS6-10CI
150mm	EZS3-15CI	EZS4-15CI	EZS6-15CI
200mm	EZS3-20CI	EZS4-20CI	EZS6-20CI
250mm	EZS3-25CI	EZS4-25CI	EZS6-25CI
300mm	EZS3-30CI	EZS4-30CI	EZS6-30CI
400mm	EZS3-40CI	EZS4-40CI	EZS6-40CI
500mm	EZS3-50CI	EZS4-50CI	EZS6-50CI

With Electromagnetic Brake 24 VDC Input

Stroke	Model		
50mm	EZS3-05MCI	EZS4-05MCI	—
100mm	EZS3-10MCI	EZS4-10MCI	EZS6-10MCI
150mm	EZS3-15MCI	EZS4-15MCI	EZS6-15MCI
200mm	EZS3-20MCI	EZS4-20MCI	EZS6-20MCI
250mm	EZS3-25MCI	EZS4-25MCI	EZS6-25MCI
300mm	EZS3-30MCI	EZS4-30MCI	EZS6-30MCI
400mm	EZS3-40MCI	EZS4-40MCI	EZS6-40MCI
500mm	EZS3-50MCI	EZS4-50MCI	EZS6-50MCI

◇ Absolute Type

Without Electromagnetic Brake 24 VDC Input

Stroke	Model		
50mm	EZS3-05CA	EZS4-05CA	—
100mm	EZS3-10CA	EZS4-10CA	EZS6-10CA
150mm	EZS3-15CA	EZS4-15CA	EZS6-15CA
200mm	EZS3-20CA	EZS4-20CA	EZS6-20CA
250mm	EZS3-25CA	EZS4-25CA	EZS6-25CA
300mm	EZS3-30CA	EZS4-30CA	EZS6-30CA
400mm	EZS3-40CA	EZS4-40CA	EZS6-40CA
500mm	EZS3-50CA	EZS4-50CA	EZS6-50CA

With Electromagnetic Brake 24 VDC Input

Stroke	Model		
50mm	EZS3-05MCA	EZS4-05MCA	—
100mm	EZS3-10MCA	EZS4-10MCA	EZS6-10MCA
150mm	EZS3-15MCA	EZS4-15MCA	EZS6-15MCA
200mm	EZS3-20MCA	EZS4-20MCA	EZS6-20MCA
250mm	EZS3-25MCA	EZS4-25MCA	EZS6-25MCA
300mm	EZS3-30MCA	EZS4-30MCA	EZS6-30MCA
400mm	EZS3-40MCA	EZS4-40MCA	EZS6-40MCA
500mm	EZS3-50MCA	EZS4-50MCA	EZS6-50MCA

■ Product Number Code

●EZS Series

EZS **4** - **10** **M** **C** **I**

① ② ③ ④ ⑤ ⑥

①	EZS Series	④	None : Without Electromagnetic Brake M : With Electromagnetic Brake
②	Size of Linear Slide	⑤	With Controller
③	Stroke 05 : 50mm 10 : 100mm 15 : 150mm 20 : 200mm 25 : 250mm 30 : 300mm 40 : 400mm 50 : 500mm	⑥	I : Incremental Type A : Absolute Type

●EZHS Series

◇Incremental Type

Without Electromagnetic Brake Single-Phase 100-115 V Input

Stroke	Model		
50mm	EZHS3A-05I	EZHS4A-05I	—
100mm	EZHS3A-10I	EZHS4A-10I	EZHS6A-10I
150mm	EZHS3A-15I	EZHS4A-15I	EZHS6A-15I
200mm	EZHS3A-20I	EZHS4A-20I	EZHS6A-20I
250mm	EZHS3A-25I	EZHS4A-25I	EZHS6A-25I
300mm	EZHS3A-30I	EZHS4A-30I	EZHS6A-30I
400mm	EZHS3A-40I	EZHS4A-40I	EZHS6A-40I
500mm	EZHS3A-50I	EZHS4A-50I	EZHS6A-50I

Single-Phase 200-230 V Input

Stroke	Model
50mm	—
100mm	EZHS6C-10I
150mm	EZHS6C-15I
200mm	EZHS6C-20I
250mm	EZHS6C-25I
300mm	EZHS6C-30I
400mm	EZHS6C-40I
500mm	EZHS6C-50I

With Electromagnetic Brake Single-Phase 100-115 V Input

Stroke	Model		
50mm	EZHS3A-05MI	EZHS4A-05MI	—
100mm	EZHS3A-10MI	EZHS4A-10MI	EZHS6A-10MI
150mm	EZHS3A-15MI	EZHS4A-15MI	EZHS6A-15MI
200mm	EZHS3A-20MI	EZHS4A-20MI	EZHS6A-20MI
250mm	EZHS3A-25MI	EZHS4A-25MI	EZHS6A-25MI
300mm	EZHS3A-30MI	EZHS4A-30MI	EZHS6A-30MI
400mm	EZHS3A-40MI	EZHS4A-40MI	EZHS6A-40MI
500mm	EZHS3A-50MI	EZHS4A-50MI	EZHS6A-50MI

Single-Phase 200-230 V Input

Stroke	Model
50mm	—
100mm	EZHS6C-10MI
150mm	EZHS6C-15MI
200mm	EZHS6C-20MI
250mm	EZHS6C-25MI
300mm	EZHS6C-30MI
400mm	EZHS6C-40MI
500mm	EZHS6C-50MI

◇Absolute Type

Without Electromagnetic Brake Single-Phase 100-115 V Input

Stroke	Model		
50mm	EZHS3A-05A	EZHS4A-05A	—
100mm	EZHS3A-10A	EZHS4A-10A	EZHS6A-10A
150mm	EZHS3A-15A	EZHS4A-15A	EZHS6A-15A
200mm	EZHS3A-20A	EZHS4A-20A	EZHS6A-20A
250mm	EZHS3A-25A	EZHS4A-25A	EZHS6A-25A
300mm	EZHS3A-30A	EZHS4A-30A	EZHS6A-30A
400mm	EZHS3A-40A	EZHS4A-40A	EZHS6A-40A
500mm	EZHS3A-50A	EZHS4A-50A	EZHS6A-50A

Single-Phase 200-230 V Input

Stroke	Model
50mm	—
100mm	EZHS6C-10A
150mm	EZHS6C-15A
200mm	EZHS6C-20A
250mm	EZHS6C-25A
300mm	EZHS6C-30A
400mm	EZHS6C-40A
500mm	EZHS6C-50A

With Electromagnetic Brake Single-Phase 100-115 V Input

Stroke	Model		
50mm	EZHS3A-05MA	EZHS4A-05MA	—
100mm	EZHS3A-10MA	EZHS4A-10MA	EZHS6A-10MA
150mm	EZHS3A-15MA	EZHS4A-15MA	EZHS6A-15MA
200mm	EZHS3A-20MA	EZHS4A-20MA	EZHS6A-20MA
250mm	EZHS3A-25MA	EZHS4A-25MA	EZHS6A-25MA
300mm	EZHS3A-30MA	EZHS4A-30MA	EZHS6A-30MA
400mm	EZHS3A-40MA	EZHS4A-40MA	EZHS6A-40MA
500mm	EZHS3A-50MA	EZHS4A-50MA	EZHS6A-50MA

Single-Phase 200-230 V Input

Stroke	Model
50mm	—
100mm	EZHS6C-10MA
150mm	EZHS6C-15MA
200mm	EZHS6C-20MA
250mm	EZHS6C-25MA
300mm	EZHS6C-30MA
400mm	EZHS6C-40MA
500mm	EZHS6C-50MA

■ Product Number Code

●EZHS Series

EZHS 4 A - 10 M I
 ① ② ③ ④ ⑤ ⑥

①	EZHS Series		Stroke 05 : 50mm 10 :100mm 15 :150mm 20 :200mm 25 :250mm 30 :300mm 40 :400mm 50 :500mm
②	Size of Linear Slide	④	
③	Power Supply A : Single-Phase 100-115V C : Single-Phase 200-230V	⑤	None : Without Electromagnetic Brake M : With Electromagnetic Brake
		⑥	I : Incremental Type A : Absolute Type

EZS Series

EZS3

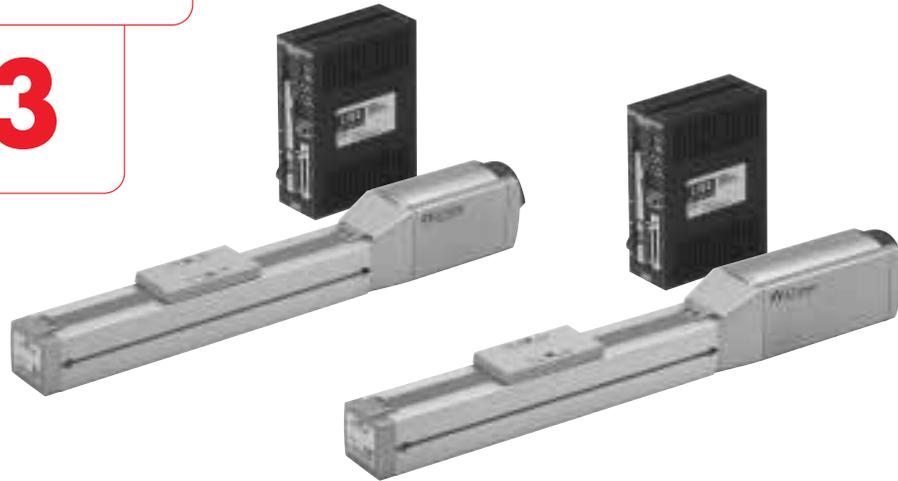

Specifications

Model	Incremental Type		EZS3-□CI		EZS3-□MCI			
	Absolute Type		EZS3-□CA		EZS3-□MCA			
Motor Type	Stepping Motor with Encoder							
Drive Method	Ball Screw							
Electromagnetic Brake	Not equipped				Equipped			
Speed Range	mm/s		~300		~300			
Max. Transportable Mass	kg	Horizontal Direction	5		5			
		Vertical Direction	—		2			
Max. Acceleration	m/s ²	Horizontal Direction	2		2			
		Vertical Direction	—		2			
Max. Thrust Force	N kgf			23	2.3	23	2.3	
		Power ON			23	2.3	23	2.3
Max. Holding Brake Force	N kgf	Power OFF	—		—			
		Electromagnetic Brake	—		23	2.3		
Repetitive Positioning Accuracy	mm		±0.02					
Resolution	mm		0.015					
Lead	mm		12					
Stroke	mm		50, 100, 150, 200, 250, 300, 400, 500					
Mass of Linear Slide	Figure in the parentheses shows the mass of the model with electromagnetic brake.		kg	Stroke	50 : 1.5 (1.7)	100 : 1.6 (1.8)	150 : 1.7 (1.9)	200 : 1.8 (2.0)
					250 : 1.9 (2.1)	300 : 2.0 (2.2)	400 : 2.2 (2.4)	500 : 2.4 (2.6)
Ambient Temperature	°C		0~+40 (Nonfreezing)					

● See page 52 for the specification and dimensions of the controller.

General Specifications

Item	Specification
Insulation Resistance	100 MΩ minimum when measured by a DC 500 V megger between the following places. <ul style="list-style-type: none"> • Windings — Case • Case — Windings of electromagnetic brake (Only for electromagnetic brake equipped model)
Dielectric Strength	Sufficient to withstand the following for one minute. <ul style="list-style-type: none"> • Windings — Case AC 0.5 kV 50 Hz • Case — Windings of electromagnetic brake AC 0.5 kV 50 Hz (Only for electromagnetic brake equipped model)

Linear Slide/Controller Combinations

Type	Electromagnetic Brake	Model	Linear Slide Model	Controller Model
Incremental Type	Not equipped	EZS3-□CI	EZS3-□	EZMC36I
	Equipped	EZS3-□MCI	EZS3-□M	
Absolute Type	Not equipped	EZS3-□CA	EZS3-□	EZMC36A
	Equipped	EZS3-□MCA	EZS3-□M	

*The box (□) in the model name and linear slide model name represents the code for stroke length.

Allowable Overhung Length (mm)

* The length from the center of load's mounting surface to the center of gravity of the object being carried.

- Horizontal Installation
- Wall Mount Installation
- Vertical Installation

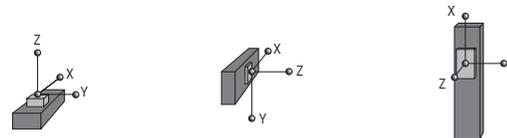

Carried Weight	Horizontal Installation			Carried Weight	Wall Mount Installation			Carried Weight	Vertical Installation		
	X	Y	Z		X	Y	Z		X	Y	Z
1kg	205	300	300	1kg	155	300	300	0.5kg	300	257	300
2.5kg	75	136	300	2.5kg	62	300	105	1kg	142	129	142
5kg	32	58	157	5kg	22	106	31	2kg	62	62	52

The values shown in the tables are for uni-axial loading. For multi-axis loading please contact an Oriental Motor representative for assistance.

Correlation Diagram of Speed and Load Weight

● Horizontal Direction

● Vertical Direction

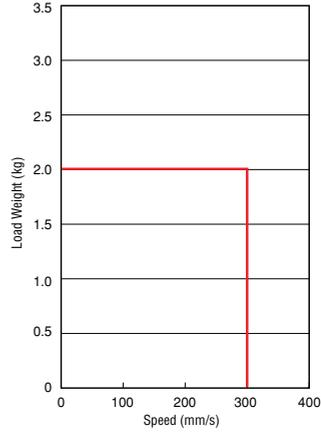
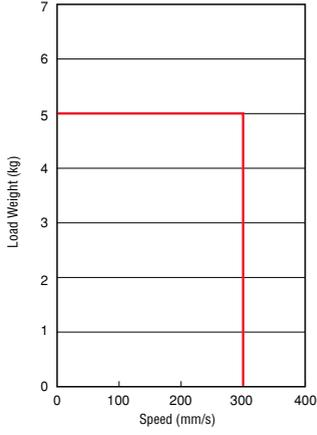

Minimum Positioning Time

Acceleration: 2 m/s² Starting Speed: 6 mm/s

● Horizontal Direction/ Vertical Direction

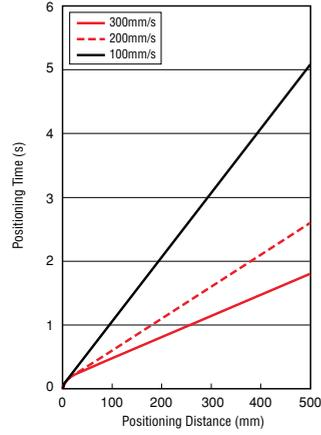

Enlargement of Positioning Distance under 100 mm

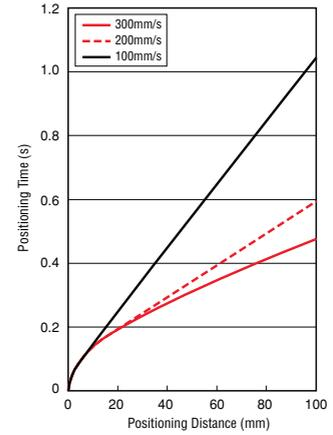

Dimensions unit: mm

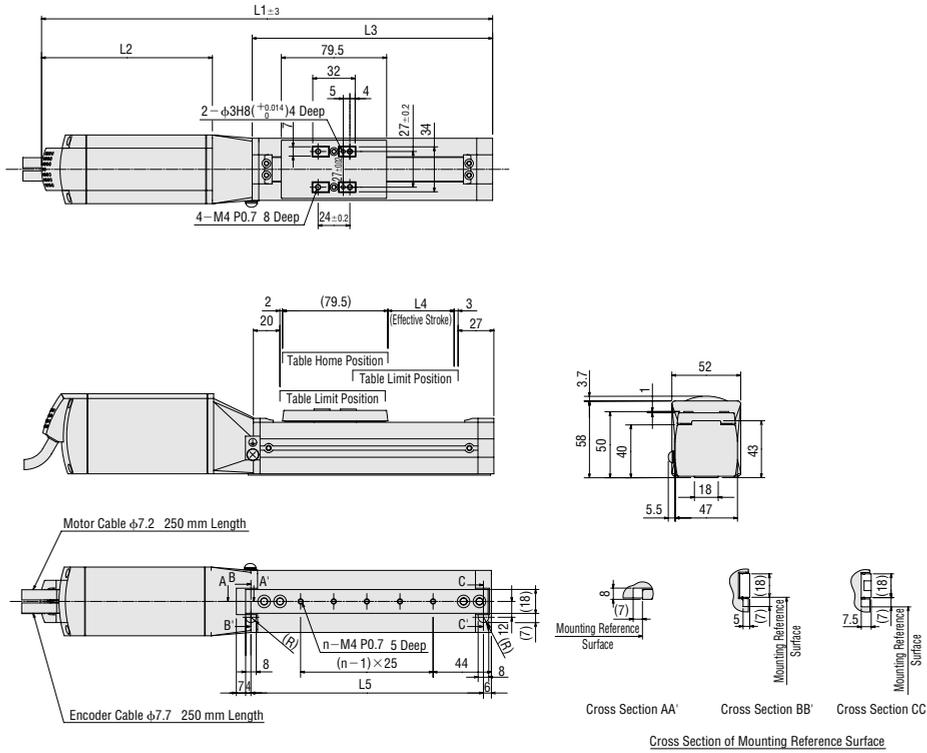

Linear Slide Model	L1	L2	L3	L4	L5	n
EZS3-05	340.5	129	181.5	50	175.5	5
EZS3-05M	370.5	159				
EZS3-10	390.5	129	231.5	100	225.5	7
EZS3-10M	420.5	159				
EZS3-15	440.5	129	281.5	150	275.5	9
EZS3-15M	470.5	159				
EZS3-20	490.5	129	331.5	200	325.5	11
EZS3-20M	520.5	159				
EZS3-25	540.5	129	381.5	250	375.5	13
EZS3-25M	570.5	159				
EZS3-30	590.5	129	431.5	300	425.5	15
EZS3-30M	620.5	159				
EZS3-40	690.5	129	531.5	400	525.5	19
EZS3-40M	720.5	159				
EZS3-50	790.5	129	631.5	500	625.5	23
EZS3-50M	820.5	159				

EZS Series

EZS4



Specifications

Model	Incremental Type	EZS4-□CI				EZS4-□MCI							
	Absolute Type	EZS4-□CA				EZS4-□MCA							
Motor Type	Stepping Motor with Encoder												
Drive Method	Ball Screw												
Electromagnetic Brake	Not equipped												
Speed Range	mm/s	~100			~200			~300					
Max. Transportable Mass	kg	Horizontal Direction	15		10		5		4.5				
		Vertical Direction	—		—		—		2				
Max. Acceleration	m/s ²	Horizontal Direction	2		—		—		2				
		Vertical Direction	—		—		—		—				
Max. Thrust Force	N kgf	45	4.5	40	4	23	2.3	45	4.5	40	4	23	2.3
		Power ON		45		4.5		—		45		4.5	
Max. Holding Brake Force	N kgf	Power OFF		—		—		—		—		—	
		Electromagnetic Brake		—		—		—		45		4.5	
Repetitive Positioning Accuracy	mm	±0.02											
Resolution	mm	0.015											
Lead	mm	12											
Stroke	mm	50, 100, 150, 200, 250, 300, 400, 500											
Mass of Linear Slide	kg	Stroke	50 : 2.3 (2.5)		100 : 2.5 (2.7)		150 : 2.7 (2.9)		200 : 2.9 (3.1)				
			250 : 3.1 (3.3)		300 : 3.3 (3.5)		400 : 3.7 (3.9)		500 : 4.1 (4.3)				
Ambient Temperature	°C	0~+40 (Nonfreezing)											

● See page 52 for the specification and dimensions of the controller.

General Specifications

Item	Specification
Insulation Resistance	100 MΩ minimum when measured by a DC 500 V megger between the following places. <ul style="list-style-type: none"> Windings — Case Case — Windings of electromagnetic brake (Only for electromagnetic brake equipped model)
Dielectric Strength	Sufficient to withstand the following for one minute. <ul style="list-style-type: none"> Windings — Case AC 0.5 kV 50 Hz Case — Windings of electromagnetic brake AC 0.5 kV 50 Hz (Only for electromagnetic brake equipped model)

Linear Slide/Controller Combinations

Type	Electromagnetic Brake	Model	Linear Slide Model	Controller Model
Incremental Type	Not equipped	EZS4-□CI	EZS4-□	EZMC36I
	Equipped	EZS4-□MCI	EZS4-□M	
Absolute Type	Not equipped	EZS4-□CA	EZS4-□	EZMC36A
	Equipped	EZS4-□MCA	EZS4-□M	

*The box (□) in the model name and linear slide model name represents the code for stroke length.

Allowable Overhung Length (mm)

* The length from the center of load's mounting surface to the center of gravity of the object being carried.

- Horizontal Installation
- Wall Mount Installation
- Vertical Installation

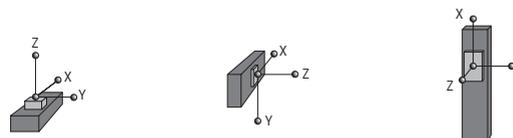

Carried Weight	Horizontal Installation			Wall Mount Installation			Vertical Installation		
	X	Y	Z	X	Y	Z	X	Y	Z
5kg	113	135	300	28	135	237	230	57	230
10kg	51	67	252	14	67	99	102	29	102
15kg	31	45	150	9	45	53	87	25	87

The values shown in the tables are for uni-axial loading. For multi-axis loading please contact an Oriental Motor representative for assistance.

Correlation Diagram of Speed and Load Weight

● Horizontal Direction

● Vertical Direction

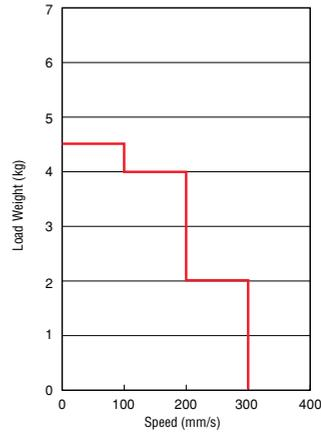
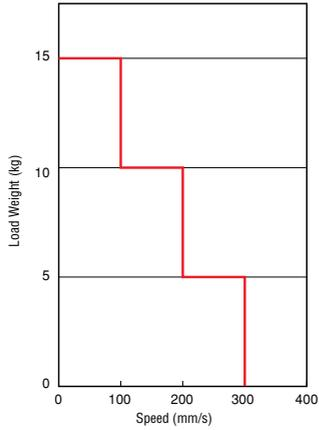

Minimum Positioning Time

Acceleration: 2 m/s² Starting Speed: 6 mm/s

● Horizontal Direction/ Vertical Direction

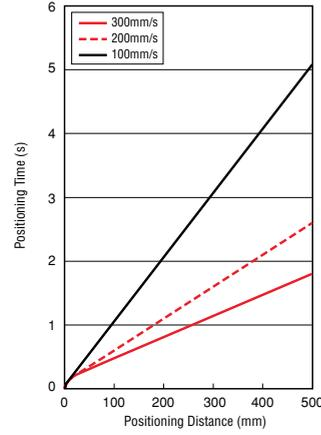

Enlargement of Positioning Distance under 100 mm

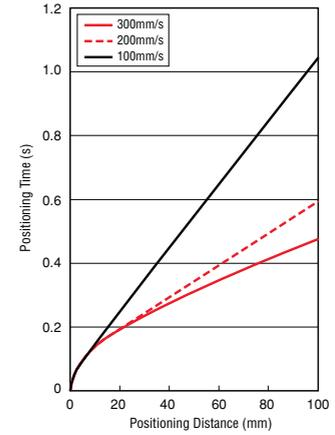

Dimensions unit: mm

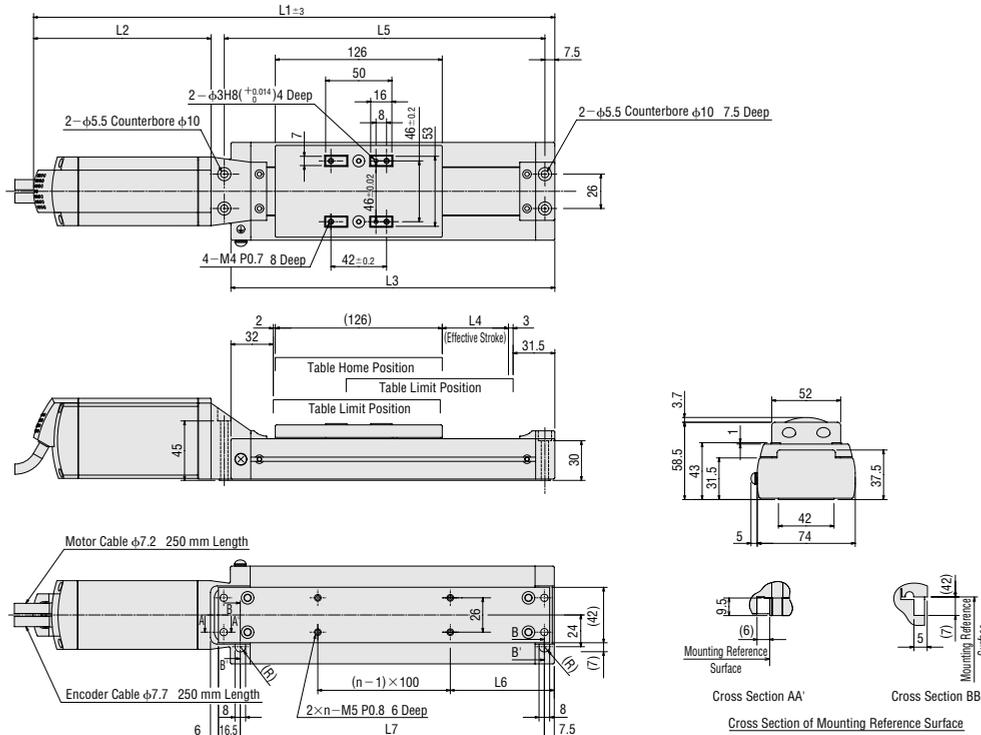

Linear Slide Model	L1	L2	L3	L4	L5	L6	L7	n
EZS4-05	393.5	134	244.5	50	242	78.5	229.5	2
EZS4-05M	423.5	164						
EZS4-10	443.5	134	294.5	100	292	53.5	279.5	3
EZS4-10M	473.5	164						
EZS4-15	493.5	134	344.5	150	342	78.5	329.5	3
EZS4-15M	523.5	164						
EZS4-20	543.5	134	394.5	200	392	53.5	379.5	4
EZS4-20M	573.5	164						
EZS4-25	593.5	134	444.5	250	442	78.5	429.5	4
EZS4-25M	623.5	164						
EZS4-30	643.5	134	494.5	300	492	53.5	479.5	5
EZS4-30M	673.5	164						
EZS4-40	743.5	134	594.5	400	592	53.5	579.5	6
EZS4-40M	773.5	164						
EZS4-50	843.5	134	694.5	500	692	53.5	679.5	7
EZS4-50M	873.5	164						

EZS Series

EZS6

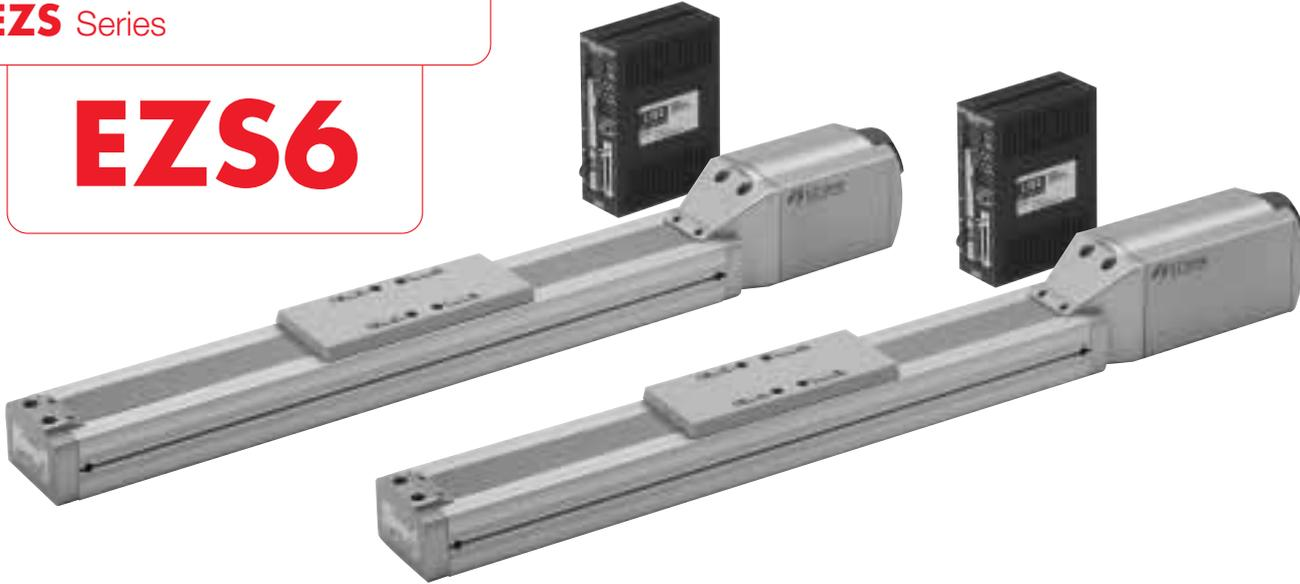

Specifications

Model	Incremental Type		EZS6-□CI				EZS6-□MCI				
	Absolute Type		EZS6-□CA				EZS6-□MCA				
Motor Type	Stepping Motor with Encoder										
Drive Method	Ball Screw										
Electromagnetic Brake	Not equipped										
Speed Range	mm/s		~100	~200	~300	~100	~200	~300			
Max. Transportable Mass	kg	Horizontal Direction	30	20	10	30	20	10			
		Vertical Direction	—	—	—	10	8	3			
Max. Acceleration	m/s ²	Horizontal Direction	2				2				
		Vertical Direction	—				2				
Max. Thrust Force	N kgf		100 10	94 9.4	35 3.5	100 10	94 9.4	35 3.5			
				100 10			100 10				
Max. Holding Brake Force	N kgf	Power ON	100 10				100 10				
		Power OFF	—				—				
		Electromagnetic Brake	—				100 10				
Repetitive Positioning Accuracy	mm	±0.02									
Resolution	mm	0.015									
Lead	mm	12									
Stroke	mm	100, 150, 200, 250, 300, 400, 500									
Mass of Linear Slide	kg	Figure in the parentheses shows the mass of the model with electromagnetic brake.	Stroke	100 : 4.0 (4.4)	150 : 4.3 (4.7)	200 : 4.5 (4.9)	250 : 4.7 (5.1)				
				300 : 5.0 (5.4)	400 : 5.5 (5.9)	500 : 5.9 (6.3)					
Ambient Temperature	°C	0~+40 (Nonfreezing)									

● See page 52 for the specification and dimensions of the controller.

General Specifications

Item	Specification
Insulation Resistance	100 MΩ minimum when measured by a DC 500 V megger between the following places. • Windings — Case • Case — Windings of electromagnetic brake (Only for electromagnetic brake equipped model)
Dielectric Strength	Sufficient to withstand the following for one minute. • Windings — Case AC 1.0 kV 50 Hz • Case — Windings of electromagnetic brake AC 1.0 kV 50 Hz (Only for electromagnetic brake equipped model)

Linear Slide/Controller Combinations

Type	Electromagnetic Brake	Model	Linear Slide Model	Controller Model
Incremental Type	Not equipped	EZS6-□CI	EZS6-□	EZMC36I
	Equipped	EZS6-□MCI	EZS6-□M	
Absolute Type	Not equipped	EZS6-□CA	EZS6-□	EZMC36A
	Equipped	EZS6-□MCA	EZS6-□M	

*The box (□) in the model name and linear slide model name represents the code for stroke length.

Allowable Overhung Length (mm)

* The length from the center of load's mounting surface to the center of gravity of the object being carried.

• Horizontal Installation • Wall Mount Installation • Vertical Installation

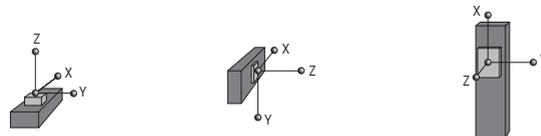

Carried Weight	X	Y	Z	Carried Weight	X	Y	Z	Carried Weight	X	Y	Z
10kg	500	414	500	10kg	100	490	414	3kg	500	277	500
20kg	386	207	500	20kg	50	245	179	8kg	500	104	500
30kg	257	137	500	30kg	33	163	100	10kg	500	83	500

The values shown in the tables are for uni-axial loading. For multi-axis loading please contact an Oriental Motor representative for assistance.

Correlation Diagram of Speed and Load Weight

● Horizontal Direction

● Vertical Direction

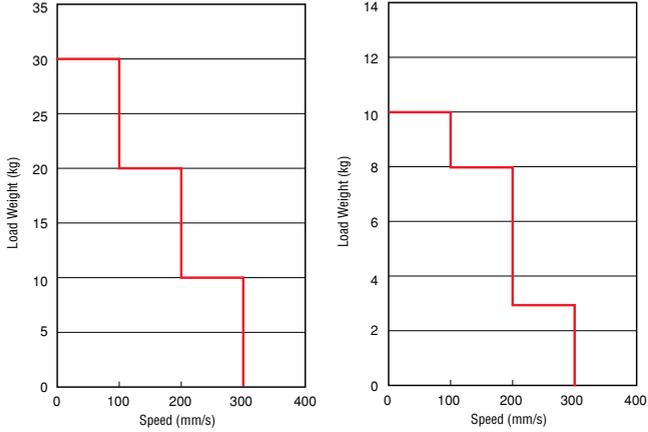

Minimum Positioning Time Acceleration: 2 m/s² Starting Speed: 6 mm/s

● Horizontal Direction/ Vertical Direction

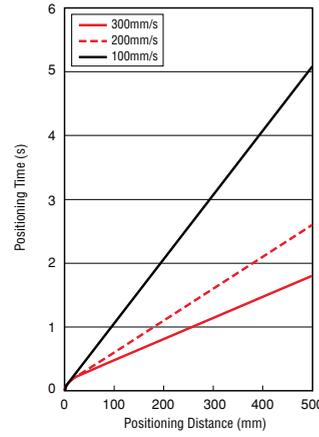

Enlargement of Positioning Distance under 100 mm

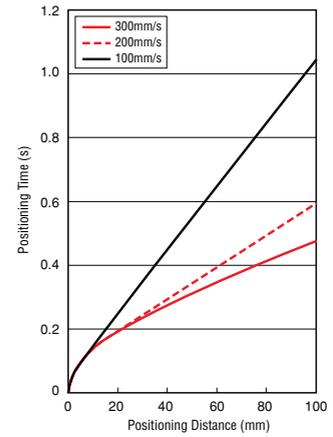

Dimensions unit: mm

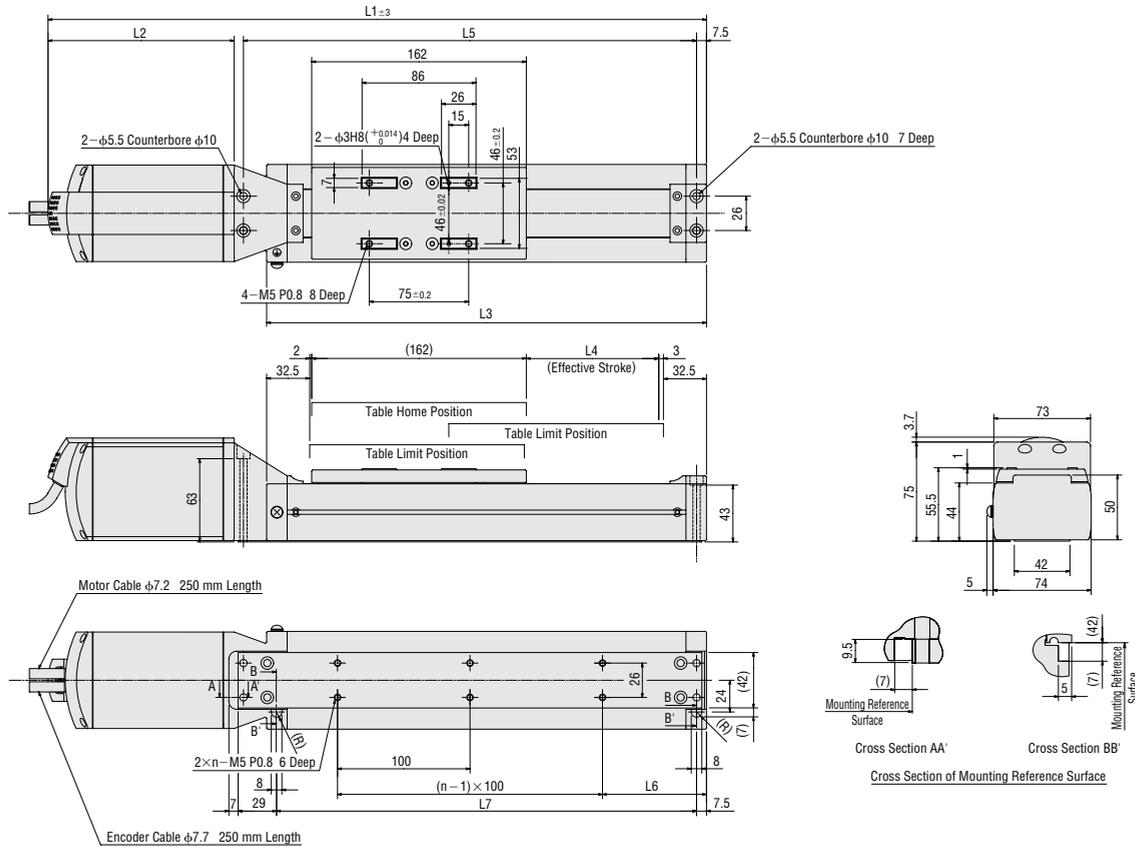

Linear Slide Model	L1	L2	L3	L4	L5	L6	L7	n
EZS6-10	497	140.5	332	100	342	78.5	317	3
EZS6-10M	532	175.5						
EZS6-15	547	140.5	382	150	392	53.5	367	4
EZS6-15M	582	175.5						
EZS6-20	597	140.5	432	200	442	78.5	417	4
EZS6-20M	632	175.5						
EZS6-25	647	140.5	482	250	492	53.5	467	5
EZS6-25M	682	175.5						
EZS6-30	697	140.5	532	300	542	78.5	517	5
EZS6-30M	732	175.5						
EZS6-40	797	140.5	632	400	642	78.5	617	6
EZS6-40M	832	175.5						
EZS6-50	897	140.5	732	500	742	78.5	717	7
EZS6-50M	932	175.5						

EZHS Series

EZHS3

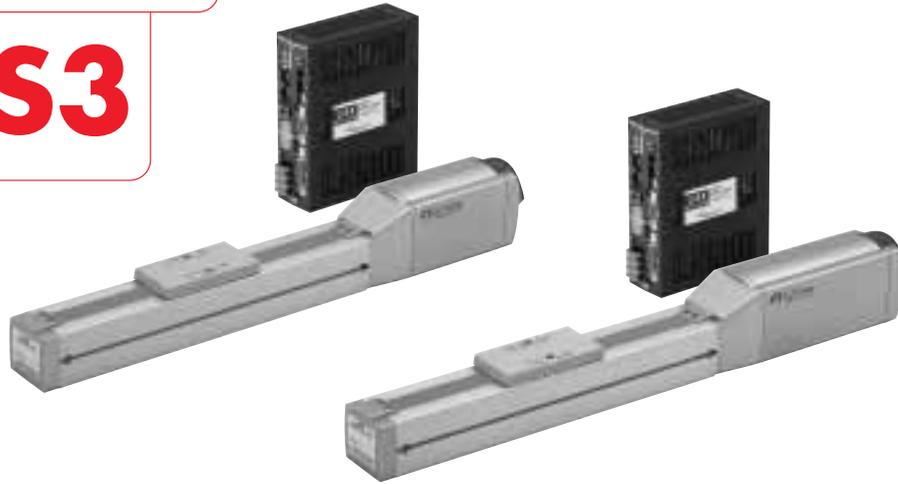

Specifications

Model	Incremental Type		EZHS3A-□I		EZHS3A-□MI		
	Absolute Type		EZHS3A-□A		EZHS3A-□MA		
Motor Type	Stepping Motor with Built-in Rotor-Position Sensor						
Drive Method	Ball Screw						
Electromagnetic Brake	Not equipped				Equipped		
Speed Range	mm/s		~800		~800		
Max. Transportable Mass	kg	Horizontal Direction	5		5		
		Vertical Direction	—		2.5		
Max. Acceleration	m/s ²	Horizontal Direction	2.5		2.5		
		Vertical Direction	—		2.5		
Max. Thrust Force	N kgf	30 3		30 3			
		Power ON	30 3		30 3		
Max. Holding Brake Force	N kgf	Power OFF	—		—		
		Electromagnetic Brake	—		30 3		
Repetitive Positioning Accuracy	mm		±0.02				
Resolution	mm		0.01				
Lead	mm		12				
Stroke	mm		50, 100, 150, 200, 250, 300, 400, 500				
Mass of Linear Slide	Figure in the parentheses shows the mass of the model with electromagnetic brake. kg		Stroke	50 : 1.6 (1.8)	100 : 1.7 (1.9)	150 : 1.8 (2.0)	200 : 1.9 (2.1)
				250 : 2.0 (2.2)	300 : 2.1 (2.3)	400 : 2.3 (2.5)	500 : 2.5 (2.7)
Ambient Temperature	°C		0~+40(Nonfreezing)				

● See page 54 for the specification and dimensions of the controller.

General Specifications

Item	Specification
Insulation Resistance	100 MΩ minimum when measured by a DC 500 V megger between the following places. • Windings — Case • Case — Windings of electromagnetic brake (Only for electromagnetic brake equipped model)
Dielectric Strength	Sufficient to withstand the following for one minute. • Windings — Case AC 1.0 kV 50 Hz • Case — Windings of electromagnetic brake AC 1.0 kV 50 Hz (Only for electromagnetic brake equipped model)

Linear Slide/Controller Combinations

Type	Electromagnetic Brake	Model	Linear Slide Model	Controller Model
Incremental Type	Not equipped	EZHS3A-□I	EZHS3A-□	EZMC13I-A
	Equipped	EZHS3A-□MI	EZHS3A-□M	
Absolute Type	Not equipped	EZHS3A-□A	EZHS3A-□	EZMC13A-A
	Equipped	EZHS3A-□MA	EZHS3A-□M	

*The box (□) in the model name and linear slide model name represents the code for stroke length.

Allowable Overhung Length (mm)

* The length from the center of load's mounting surface to the center of gravity of the object being carried.

• Horizontal Installation • Wall Mount Installation • Vertical Installation

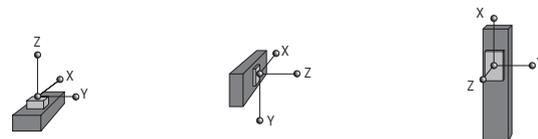

Carried Weight	Horizontal Installation			Wall Mount Installation			Vertical Installation		
	X	Y	Z	X	Y	Z	X	Y	Z
1kg	203	300	300	155	300	298	135	124	135
2.5kg	73	123	288	62	243	93	58	58	48
5kg	30	50	118	19	75	25	37	37	31

The values shown in the tables are for uni-axial loading. For multi-axis loading please contact an Oriental Motor representative for assistance.

Correlation Diagram of Speed and Load Weight

● Horizontal Direction

● Vertical Direction

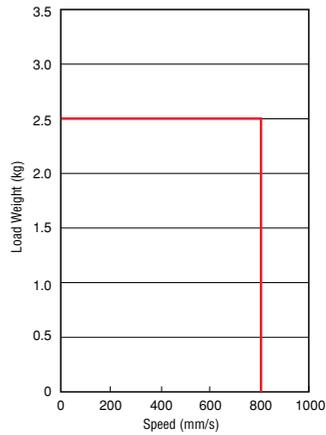
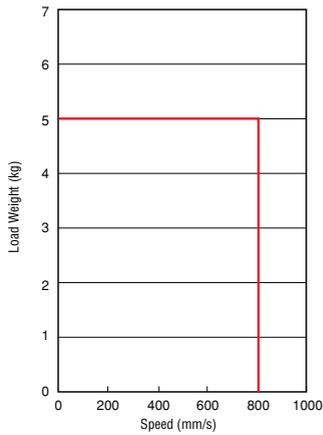

Minimum Positioning Time

Acceleration: 2.5 m/s² Starting Speed: 6 mm/s

● Horizontal Direction/ Vertical Direction

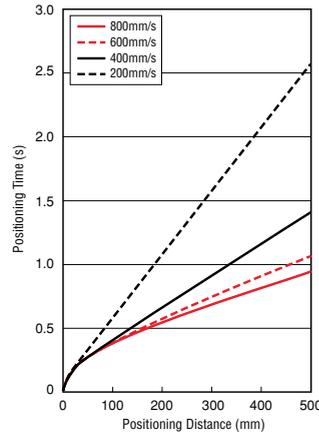

Enlargement of Positioning Distance under 100 mm

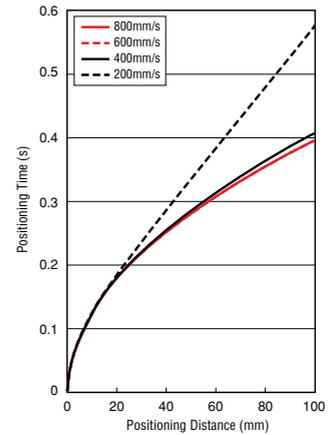

Dimensions unit: mm

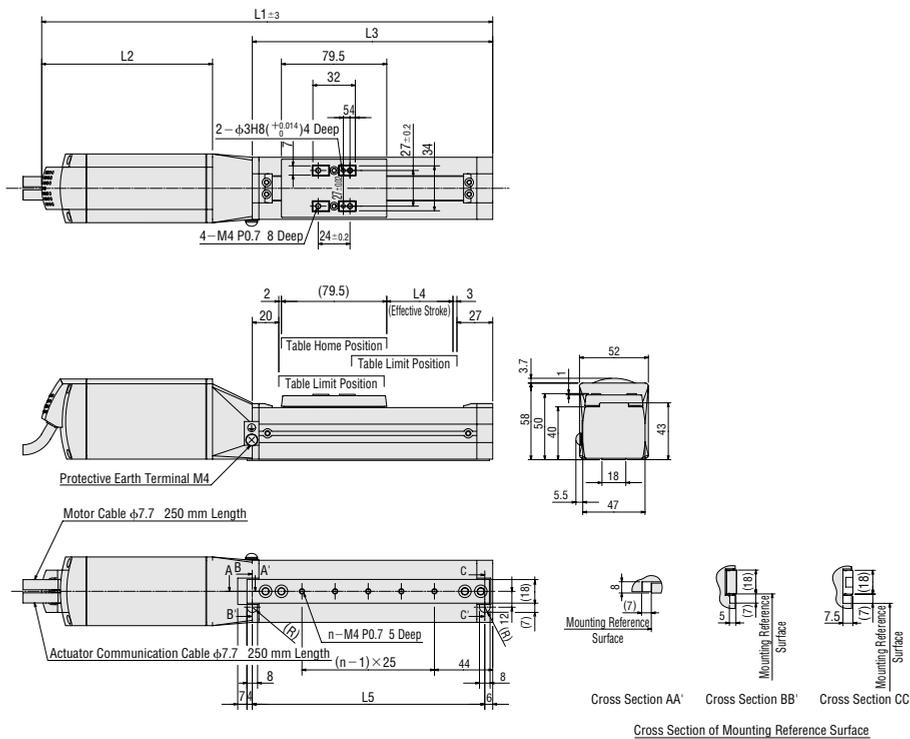

Linear Slide Model	L1	L2	L3	L4	L5	n
EZHS3A-05	340.5	129	181.5	50	175.5	5
EZHS3A-05M	370.5	159				
EZHS3A-10	390.5	129	231.5	100	225.5	7
EZHS3A-10M	420.5	159				
EZHS3A-15	440.5	129	281.5	150	275.5	9
EZHS3A-15M	470.5	159				
EZHS3A-20	490.5	129	331.5	200	325.5	11
EZHS3A-20M	520.5	159				
EZHS3A-25	540.5	129	381.5	250	375.5	13
EZHS3A-25M	570.5	159				
EZHS3A-30	590.5	129	431.5	300	425.5	15
EZHS3A-30M	620.5	159				
EZHS3A-40	690.5	129	531.5	400	525.5	19
EZHS3A-40M	720.5	159				
EZHS3A-50	790.5	129	631.5	500	625.5	23
EZHS3A-50M	820.5	159				

EZHS Series

EZHS4



Specifications

Model	Incremental Type	EZHS4A-□I				EZHS4A-□MI												
	Absolute Type	EZHS4A-□A				EZHS4A-□MA												
Motor Type	Stepping Motor with Built-in Rotor-Position Sensor																	
Drive Method	Ball Screw																	
Electromagnetic Brake	Not equipped / Equipped																	
Speed Range	mm/s	~400	~600	~800	~400	~600	~800											
Max. Transportable Mass	kg	Horizontal Direction		Vertical Direction		Horizontal Direction		Vertical Direction										
		15	—	7	4.5	3.5												
Max. Acceleration	m/s ²	Horizontal Direction		Vertical Direction		Horizontal Direction		Vertical Direction										
		2.5	—	2.5	2.5													
Max. Thrust Force	N kgf	70	7	55	5.5	43	4.3	70	7	55	5.5	43	4.3					
		Power ON		70		7		Power OFF		—		Electromagnetic Brake		70		7		
Repetitive Positioning Accuracy	mm	±0.02																
Resolution	mm	0.01																
Lead	mm	12																
Stroke	mm	50, 100, 150, 200, 250, 300, 400, 500																
Mass of Linear Slide	kg	Stroke	50		100		150		200		250		300		400		500	
			2.4 (2.6)	3.2 (3.4)	2.6 (2.8)	3.4 (3.6)	2.8 (3.0)	3.8 (4.0)	3.0 (3.2)	4.2 (4.4)								
Ambient Temperature	°C	0~+40 (Nonfreezing)																

● See page 54 for the specification and dimensions of the controller.

General Specifications

Item	Specification
Insulation Resistance	100 MΩ minimum when measured by a DC 500 V megger between the following places. <ul style="list-style-type: none"> Windings — Case Case — Windings of electromagnetic brake (Only for electromagnetic brake equipped model)
Dielectric Strength	Sufficient to withstand the following for one minute. <ul style="list-style-type: none"> Windings — Case AC 1.0 kV 50 Hz Case — Windings of electromagnetic brake AC 1.0 kV 50 Hz (Only for electromagnetic brake equipped model)

Linear Slide/Controller Combinations

Type	Electromagnetic Brake	Model	Linear Slide Model	Controller Model
Incremental Type	Not equipped	EZHS4A-□I	EZHS4A-□	EZMC13I-A
	Equipped	EZHS4A-□MI	EZHS4A-□M	
Absolute Type	Not equipped	EZHS4A-□A	EZHS4A-□	EZMC13A-A
	Equipped	EZHS4A-□MA	EZHS4A-□M	

*The box (□) in the model name and linear slide model name represents the code for stroke length.

Allowable Overhung Length (mm)

* The length from the center of load's mounting surface to the center of gravity of the object being carried.

- Horizontal Installation
- Wall Mount Installation
- Vertical Installation

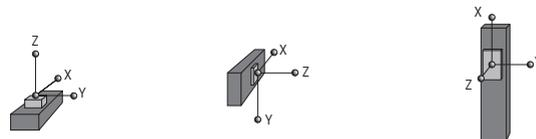

Carried Weight	X	Y	Z	Carried Weight	X	Y	Z	Carried Weight	X	Y	Z
5kg	158	108	300	5kg	28	108	300	3.5kg	166	31	166
10kg	73	54	286	10kg	14	54	132	4.5kg	123	24	123
15kg	45	36	175	15kg	9	36	76	7kg	69	16	69

The values shown in the tables are for uni-axial loading. For multi-axis loading please contact an Oriental Motor representative for assistance.

Correlation Diagram of Speed and Load Weight

● Horizontal Direction

● Vertical Direction

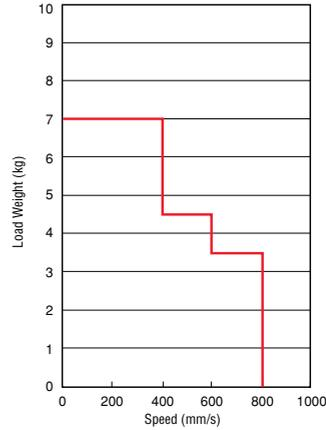
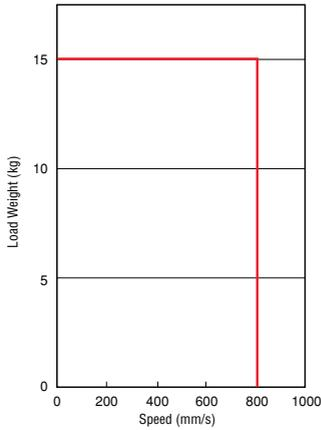

Minimum Positioning Time

Acceleration: 2.5 m/s² Starting Speed: 6 mm/s

● Horizontal Direction/ Vertical Direction

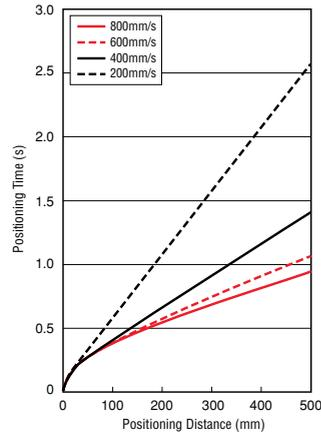

Enlargement of Positioning Distance under 100 mm

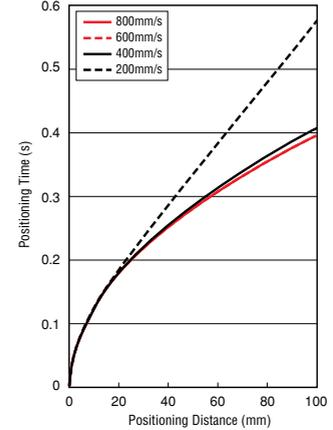

Dimensions unit: mm

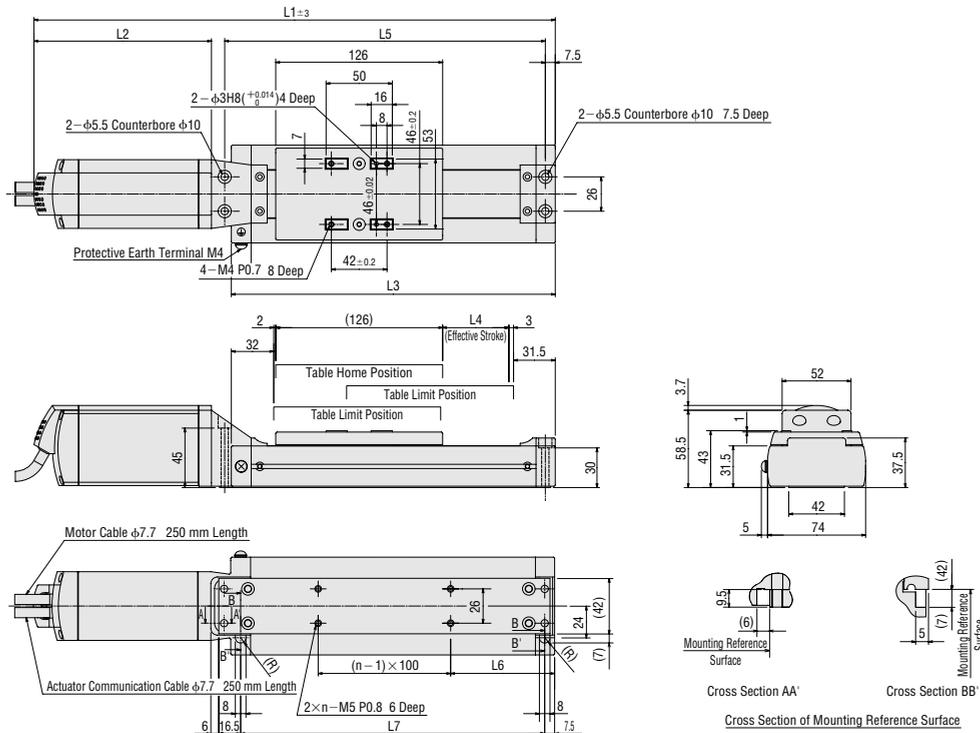

Linear Slide Model	L1	L2	L3	L4	L5	L6	L7	n
EZHS4A-05	393.5	134	244.5	50	242	78.5	229.5	2
EZHS4A-05M	423.5	164						
EZHS4A-10	443.5	134	294.5	100	292	53.5	279.5	3
EZHS4A-10M	473.5	164						
EZHS4A-15	493.5	134	344.5	150	342	78.5	329.5	3
EZHS4A-15M	523.5	164						
EZHS4A-20	543.5	134	394.5	200	392	53.5	379.5	4
EZHS4A-20M	573.5	164						
EZHS4A-25	593.5	134	444.5	250	442	78.5	429.5	4
EZHS4A-25M	623.5	164						
EZHS4A-30	643.5	134	494.5	300	492	53.5	479.5	5
EZHS4A-30M	673.5	164						
EZHS4A-40	743.5	134	594.5	400	592	53.5	579.5	6
EZHS4A-40M	773.5	164						
EZHS4A-50	843.5	134	694.5	500	692	53.5	679.5	7
EZHS4A-50M	873.5	164						

EZHS Series

EZHS6



Specifications

Model	Incremental Type		EZHS6A-□I, EZHS6C-□I						EZHS6A-□MI, EZHS6C-□MI								
	Absolute Type		EZHS6A-□A, EZHS6C-□A						EZHS6A-□MA, EZHS6C-□MA								
Motor Type	Stepping Motor with Built-in Rotor-Position Sensor																
Drive Method	Ball Screw																
Electromagnetic Brake	Not equipped						Equipped										
Speed Range	mm/s		~400		~600		~800		~400		~600		~800				
Max. Transportable Mass	kg	Horizontal Direction	30		20		15		30		7.5		3.5				
		Vertical Direction	—		—		—		—		—		—				
Max. Acceleration	m/s ²	Horizontal Direction	2.5						2.5								
		Vertical Direction	—						2.5								
Max. Thrust Force	N kgf	184 18.4		92 9.2		50 5		184 18.4		92 9.2		50 5					
		Power ON	184 18.4						184 18.4								
Max. Holding Brake Force	N kgf	Power OFF	—						—								
		Electromagnetic Brake	—						184 18.4		—						
Repetitive Positioning Accuracy	mm		±0.02														
Resolution	mm		0.01														
Lead	mm		12														
Stroke	mm		100, 150, 200, 250, 300, 400, 500														
Mass of Linear Slide	kg	Figure in the parentheses shows the mass of the model with electromagnetic brake.	Stroke	100 : 4.1 (4.5)		150 : 4.4 (4.8)		200 : 4.6 (5.0)		250 : 4.8 (5.2)		300 : 5.1 (5.5)		400 : 5.6 (6.0)		500 : 6.0 (6.4)	
				Ambient Temperature		°C		0~+40 (Nonfreezing)									

● See page 54 for the specification and dimensions of the controller.

General Specifications

Item	Specification
Insulation Resistance	100 MΩ minimum when measured by a DC 500 V megger between the following places. • Windings — Case • Case — Windings of electromagnetic brake (Only for electromagnetic brake equipped model)
Dielectric Strength	Sufficient to withstand the following for one minute. • Windings — Case AC 1.5 kV 50 Hz • Case — Windings of electromagnetic brake AC 1.0 kV 50 Hz (Only for electromagnetic brake equipped model)

Allowable Overhung Length (mm)

* The length from the center of load's mounting surface to the center of gravity of the object being carried.

• Horizontal Installation

• Wall Mount Installation

• Vertical Installation

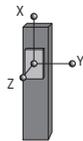

Carried Weight	X			Y			Z				
	10kg	500	392	500	10kg	100	392	414	3.5kg	500	228
20kg	386	196	500	20kg	50	196	207	7.5kg	500	106	500
30kg	257	131	500	30kg	33	131	138	15kg	410	53	410

The values shown in the tables are for uni-axial loading. For multi-axis loading please contact an Oriental Motor representative for assistance.

Linear Slide/Controller Combinations

Type	Electromagnetic Brake	Model	Linear Slide Model	Controller Model
Incremental Type	Not equipped	EZHS6A-□I	EZHS6A-□	EZMC24I-A
		EZHS6C-□I	EZHS6C-□	EZMC12I-C
	Equipped	EZHS6A-□MI	EZHS6A-□M	EZMC24I-A
		EZHS6C-□MI	EZHS6C-□M	EZMC12I-C

Type	Electromagnetic Brake	Model	Linear Slide Model	Controller Model
Absolute Type	Not equipped	EZHS6A-□A	EZHS6A-□	EZMC24A-A
		EZHS6C-□A	EZHS6C-□	EZMC12A-C
	Equipped	EZHS6A-□MA	EZHS6A-□M	EZMC24A-A
		EZHS6C-□MA	EZHS6C-□M	EZMC12A-C

*The box (□) in the model name and linear slide model name represents the code for stroke length.

Correlation Diagram of Speed and Load Weight

● Horizontal Direction ● Vertical Direction

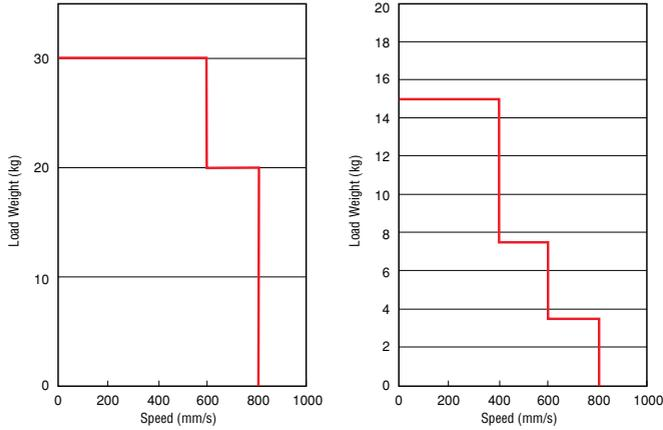

Minimum Positioning Time

Acceleration: 2.5 m/s² Starting Speed: 6 mm/s

● Horizontal Direction/ Vertical Direction

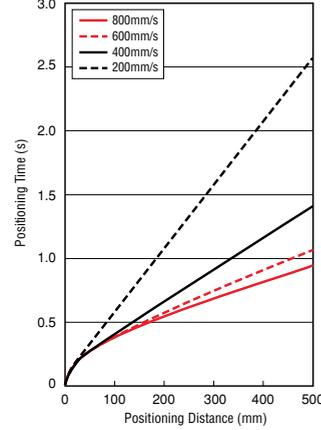

Enlargement of Positioning Distance under 100 mm

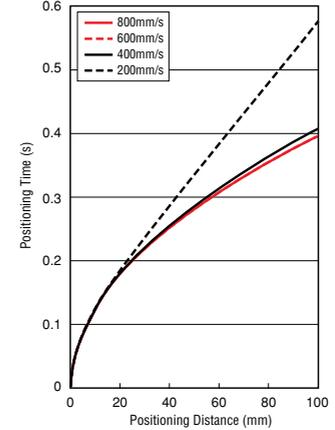

Dimensions unit: mm

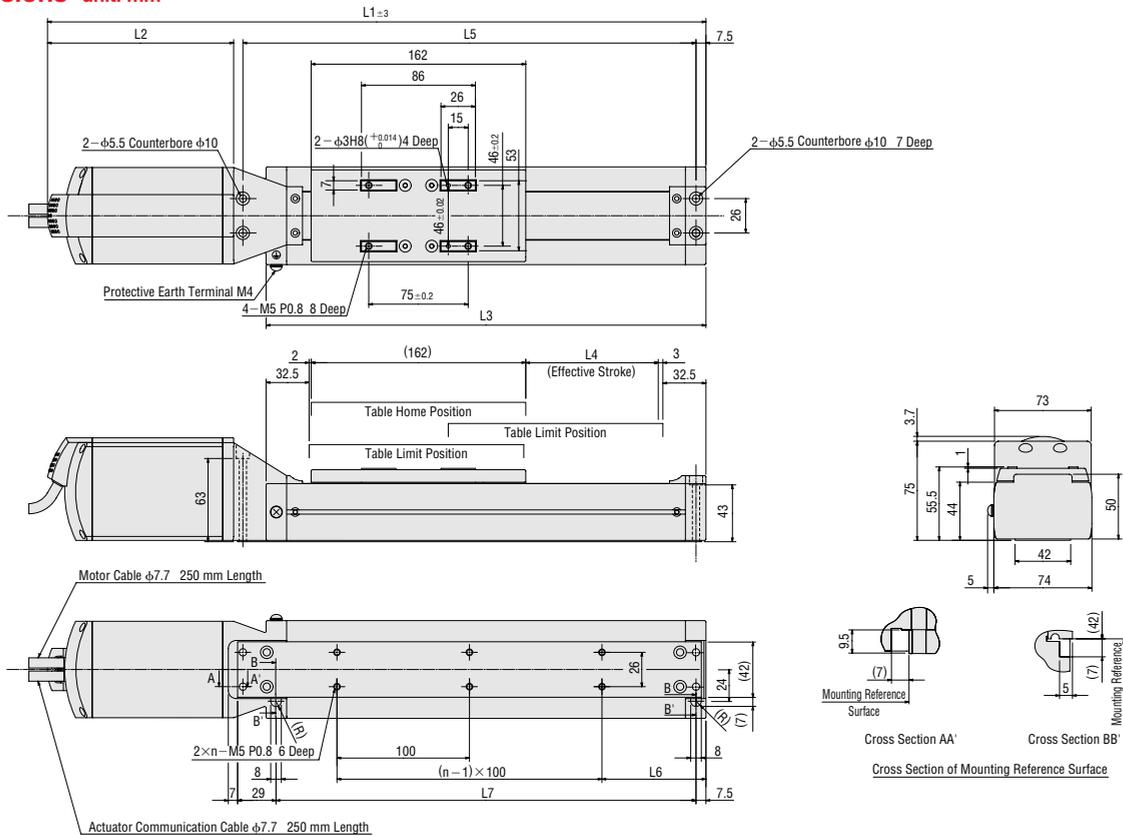

Linear Slide Model	L1	L2	L3	L4	L5	L6	L7	n
EZHS6□-10	497	140.5						
EZHS6□-10M	532	175.5	332	100	342	78.5	317	3
EZHS6□-15	547	140.5						
EZHS6□-15M	582	175.5	382	150	392	53.5	367	4
EZHS6□-20	597	140.5						
EZHS6□-20M	632	175.5	432	200	442	78.5	417	4
EZHS6□-25	647	140.5						
EZHS6□-25M	682	175.5	482	250	492	53.5	467	5
EZHS6□-30	697	140.5						
EZHS6□-30M	732	175.5	532	300	542	78.5	517	5
EZHS6□-40	797	140.5						
EZHS6□-40M	832	175.5	632	400	642	78.5	617	6
EZHS6□-50	897	140.5						
EZHS6□-50M	932	175.5	732	500	742	78.5	717	7

* Enter the power supply voltage **A** or **C** in the box (□) within the linear slide model name.

EZC Series
EZHC Series
EZHP Series

EZC Series

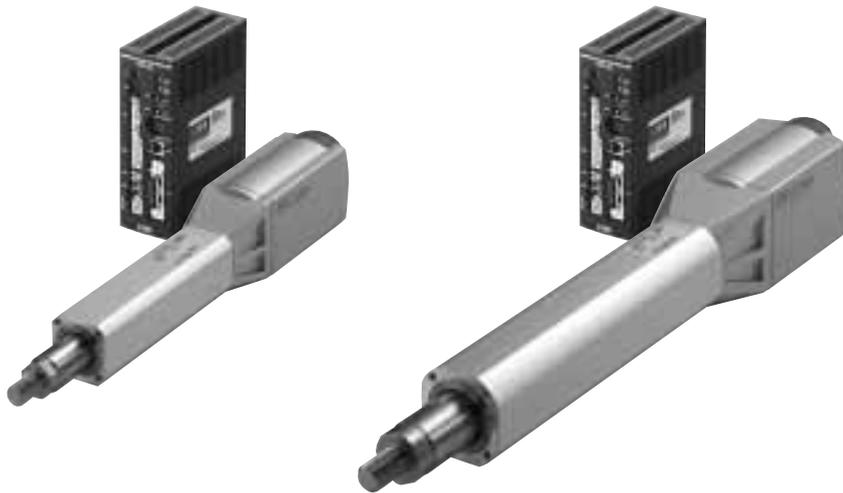

Names and Functions of the Cylinder



Mounting holes

The cylinder can be installed through the dedicated mounting holes, or via flange connection using an optional mounting bracket.

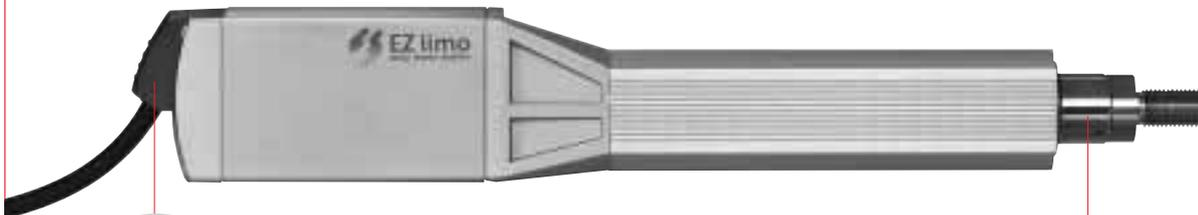

Cable

The cable outlet is facing downward, which contributes to the overall space savings by reducing the space needed to wire the cables.

Rod

EZHC Series
EZHP Series

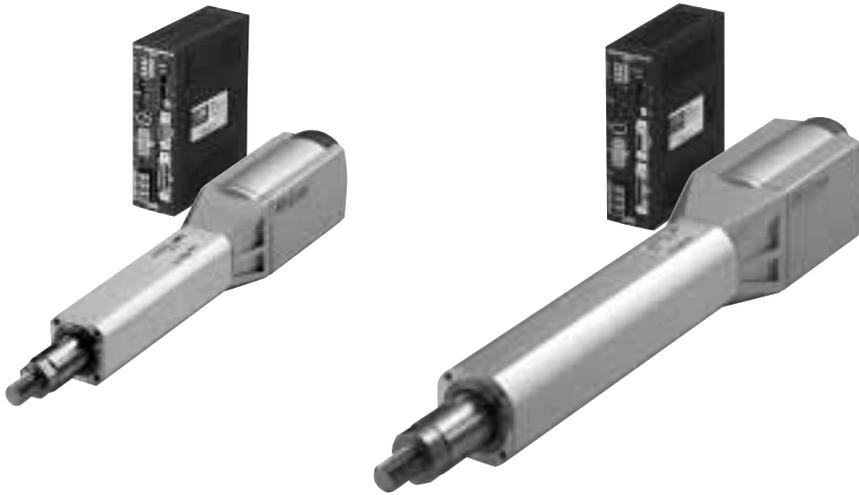

■ **Motorized Cylinder Speed – Thrust Force Characteristics**

EZC4/EZHC4/EZHP4

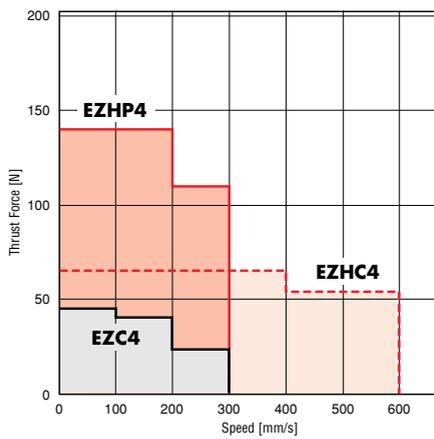

EZC6/EZHC6/EZHP6

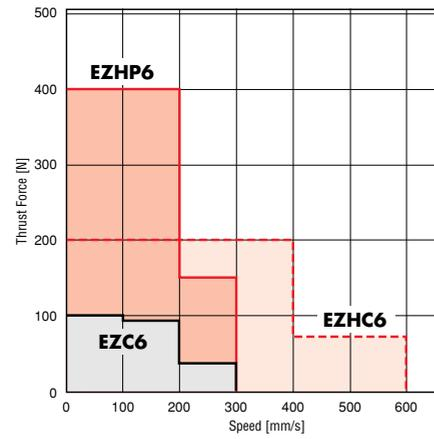

■ Models

●EZC Series

◇Incremental Type

Without Electromagnetic Brake 24 VDC Input

Stroke	Model	
50mm	EZC4-05CI	EZC6-05CI
100mm	EZC4-10CI	EZC6-10CI
200mm	EZC4-20CI	EZC6-20CI
300mm	EZC4-30CI	EZC6-30CI

With Electromagnetic Brake 24 VDC Input

Stroke	Model	
50mm	EZC4-05MCI	EZC6-05MCI
100mm	EZC4-10MCI	EZC6-10MCI
200mm	EZC4-20MCI	EZC6-20MCI
300mm	EZC4-30MCI	EZC6-30MCI

◇Absolute Type

Without Electromagnetic Brake 24 VDC Input

Stroke	Model	
50mm	EZC4-05CA	EZC6-05CA
100mm	EZC4-10CA	EZC6-10CA
200mm	EZC4-20CA	EZC6-20CA
300mm	EZC4-30CA	EZC6-30CA

With Electromagnetic Brake 24 VDC Input

Stroke	Model	
50mm	EZC4-05MCA	EZC6-05MCA
100mm	EZC4-10MCA	EZC6-10MCA
200mm	EZC4-20MCA	EZC6-20MCA
300mm	EZC4-30MCA	EZC6-30MCA

■ Product Number Code

●EZC Series

EZC **4** - **10** **M** **C** **I**

① ② ③ ④ ⑤ ⑥

①	EZC Series	④	None : Without Electromagnetic Brake M : With Electromagnetic Brake
②	Cylinder Size	⑤	With Controller
③	Stroke 05 : 50mm 10 : 100mm 20 : 200mm 30 : 300mm	⑥	I : Incremental Type A : Absolute Type

●EZHC Series、EZHP Series

EZHC **4** **A** - **10** **M** **I**

① ② ③ ④ ⑤ ⑥

①	EZHC : EZHC Series EZHP : EZHP Series	④	Stroke 05 : 50mm 10 : 100mm 20 : 200mm 30 : 300mm
②	Cylinder Size	⑤	None : Without Electromagnetic Brake M : With Electromagnetic Brake
③	Power Supply A : Single-Phase 100-115V C : Single-Phase 200-230V	⑥	I : Incremental Type A : Absolute Type

●EZHC Series

◇Incremental Type

Without Electromagnetic Brake Single-Phase 100-115 V Input

Stroke	Model	
50mm	EZHC4A-05I	EZHC6A-05I
100mm	EZHC4A-10I	EZHC6A-10I
200mm	EZHC4A-20I	EZHC6A-20I
300mm	EZHC4A-30I	EZHC6A-30I

With Electromagnetic Brake Single-Phase 100-115 V Input

Stroke	Model	
50mm	EZHC4A-05MI	EZHC6A-05MI
100mm	EZHC4A-10MI	EZHC6A-10MI
200mm	EZHC4A-20MI	EZHC6A-20MI
300mm	EZHC4A-30MI	EZHC6A-30MI

◇Absolute Type

Without Electromagnetic Brake Single-Phase 100-115 V Input

Stroke	Model	
50mm	EZHC4A-05A	EZHC6A-05A
100mm	EZHC4A-10A	EZHC6A-10A
200mm	EZHC4A-20A	EZHC6A-20A
300mm	EZHC4A-30A	EZHC6A-30A

With Electromagnetic Brake Single-Phase 100-115 V Input

Stroke	Model	
50mm	EZHC4A-05MA	EZHC6A-05MA
100mm	EZHC4A-10MA	EZHC6A-10MA
200mm	EZHC4A-20MA	EZHC6A-20MA
300mm	EZHC4A-30MA	EZHC6A-30MA

●EZHP Series

◇Incremental Type

Without Electromagnetic Brake Single-Phase 100-115V Input

Stroke	Model	
50mm	EZHP4A-05I	EZHP6A-05I
100mm	EZHP4A-10I	EZHP6A-10I
200mm	EZHP4A-20I	EZHP6A-20I
300mm	EZHP4A-30I	EZHP6A-30I

With Electromagnetic Brake Single-Phase 100-115V Input

Stroke	Model	
50mm	EZHP4A-05MI	EZHP6A-05MI
100mm	EZHP4A-10MI	EZHP6A-10MI
200mm	EZHP4A-20MI	EZHP6A-20MI
300mm	EZHP4A-30MI	EZHP6A-30MI

◇Absolute Type

Without Electromagnetic Brake Single-Phase 100-115V Input

Stroke	Model	
50mm	EZHP4A-05A	EZHP6A-05A
100mm	EZHP4A-10A	EZHP6A-10A
200mm	EZHP4A-20A	EZHP6A-20A
300mm	EZHP4A-30A	EZHP6A-30A

With Electromagnetic Brake Single-Phase 100-115V Input

Stroke	Model	
50mm	EZHP4A-05MA	EZHP6A-05MA
100mm	EZHP4A-10MA	EZHP6A-10MA
200mm	EZHP4A-20MA	EZHP6A-20MA
300mm	EZHP4A-30MA	EZHP6A-30MA

Single-Phase 200-230 V Input

Stroke	Model
50mm	EZHC6C-05I
100mm	EZHC6C-10I
200mm	EZHC6C-20I
300mm	EZHC6C-30I

Single-Phase 200-230 V Input

Stroke	Model
50mm	EZHC6C-05MI
100mm	EZHC6C-10MI
200mm	EZHC6C-20MI
300mm	EZHC6C-30MI

Single-Phase 200-230 V Input

Stroke	Model
50mm	EZHC6C-05A
100mm	EZHC6C-10A
200mm	EZHC6C-20A
300mm	EZHC6C-30A

Single-Phase 200-230 V Input

Stroke	Model
50mm	EZHC6C-05MA
100mm	EZHC6C-10MA
200mm	EZHC6C-20MA
300mm	EZHC6C-30MA

Single-Phase 200-230V Input

Stroke	Model
50mm	EZHP6C-05I
100mm	EZHP6C-10I
200mm	EZHP6C-20I
300mm	EZHP6C-30I

Single-Phase 200-230V Input

Stroke	Model
50mm	EZHP6C-05MI
100mm	EZHP6C-10MI
200mm	EZHP6C-20MI
300mm	EZHP6C-30MI

Single-Phase 200-230V Input

Stroke	Model
50mm	EZHP6C-05A
100mm	EZHP6C-10A
200mm	EZHP6C-20A
300mm	EZHP6C-30A

Single-Phase 200-230V Input

Stroke	Model
50mm	EZHP6C-05MA
100mm	EZHP6C-10MA
200mm	EZHP6C-20MA
300mm	EZHP6C-30MA

EZC Series

EZC4



Specifications

Model	Incremental Type		EZC4-□CI				EZC4-□MCI				
	Absolute Type		EZC4-□CA				EZC4-□MCA				
Motor Type	Stepping Motor with Encoder										
Drive Method	Ball Screw										
Electromagnetic Brake	Not equipped										
Speed Range	mm/s		~100	~200	~300	~100	~200	~300			
Max. Transportable Mass	kg	Horizontal Direction*	—	—	—	—	—	—			
		Vertical Direction	—	—	—	4.5	4	2			
Max. Acceleration	m/s ²	Horizontal Direction	—				—				
		Vertical Direction	—				2				
Max. Thrust Force	N kgf	45 4.5	40 4	23 2.3	45 4.5	40 4	23 2.3				
Push Force	N kgf	45 4.5 (Speed: 6 mm/s or less)									
Max. Holding Brake Force	N kgf	Power ON	45 4.5				45 4.5				
		Power OFF	—				—				
		Electromagnetic Brake	—				45 4.5				
Repetitive Positioning Accuracy	mm	±0.02									
Resolution	mm	0.015									
Lead	mm	12									
Stroke	mm	50, 100, 200, 300									
Cylinder Mass	kg	Figure in the parentheses shows the mass of the model with electromagnetic brake.	Stroke	50 : 1.6 (1.8)	100 : 1.9 (2.1)	200 : 2.4 (2.6)	300 : 2.9 (3.1)				
Ambient Temperature	°C	0~+40 (Nonfreezing)									

*In a horizontal direction, the value cannot be shown because it varies by frictional resistance of the sliding surface.

●See page 52 for the specification and dimensions of the controller.

General Specifications

Item	Specification
Insulation Resistance	100 MΩ minimum when measured by a DC 500 V megger between the following places. • Windings — Case • Case — Windings of electromagnetic brake (Only for electromagnetic brake equipped model)
Dielectric Strength	Sufficient to withstand the following for one minute. • Windings — Case AC 0.5 kV 50 Hz • Case — Windings of electromagnetic brake AC 0.5 kV 50 Hz (Only for electromagnetic brake equipped model)

Cylinder/Controller Combinations

Type	Electromagnetic Brake	Model	Cylinder Model	Controller Model
Incremental Type	Not equipped	EZC4-□CI	EZC4-□	EZMC36I
	Equipped	EZC4-□MCI	EZC4-□M	
Absolute Type	Not equipped	EZC4-□CA	EZC4-□	EZMC36A
	Equipped	EZC4-□MCA	EZC4-□M	

*The box (□) in the model name and cylinder model name represents the code for stroke length.

Push Force

Push force can be set through "Push current setting" in the parameter mode.

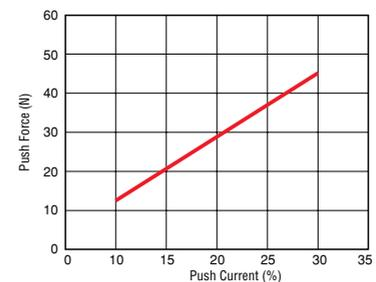

Notes:

• The above value is a reference, not guaranteed.

• When the cylinder is used in a vertical direction, an external force calculated by multiplying the weight of the carried object by the rate of gravitational acceleration is applied. Therefore, the cylinder push force must be set so as to accommodate this external force. Measure the push force using an actual load, and set an appropriate push current.

Correlation Diagram of Speed and Thrust Force

● Horizontal Direction/
Vertical Direction

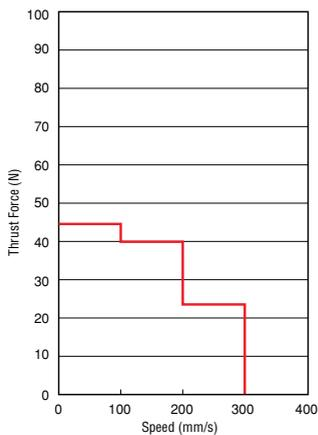

Correlation Diagram of Speed and Load Weight

● Vertical Direction

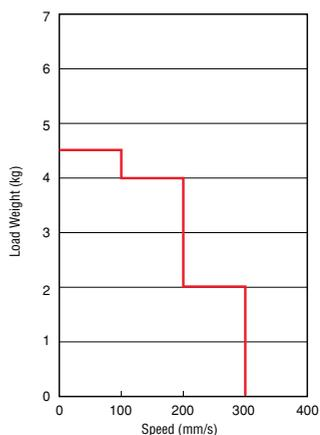

Minimum Positioning Time

Acceleration: 2 m/s² Starting Speed: 6 mm/s

● Horizontal Direction/ Vertical Direction

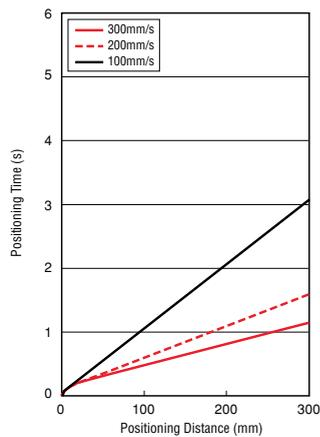

Enlargement of Positioning Distance under 100 mm

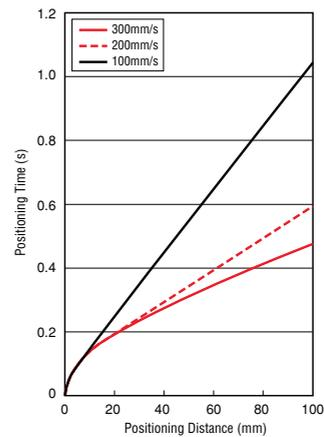

Dimensions unit: mm

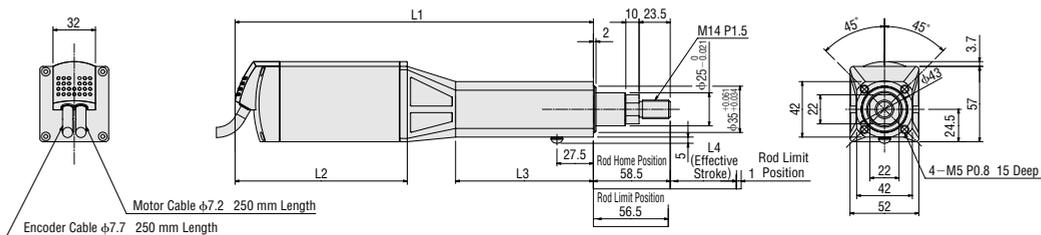

● Nut (included) 1 piece

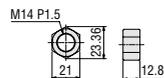

Cylinder Model	L1	L2	L3	L4
EZC4-05	270.5	130	104	50
EZC4-05M	300.5	160		
EZC4-10	320.5	130	154	100
EZC4-10M	350.5	160		
EZC4-20	420.5	130	254	200
EZC4-20M	450.5	160		
EZC4-30	520.5	130	354	300
EZC4-30M	550.5	160		

EZC Series

EZC6

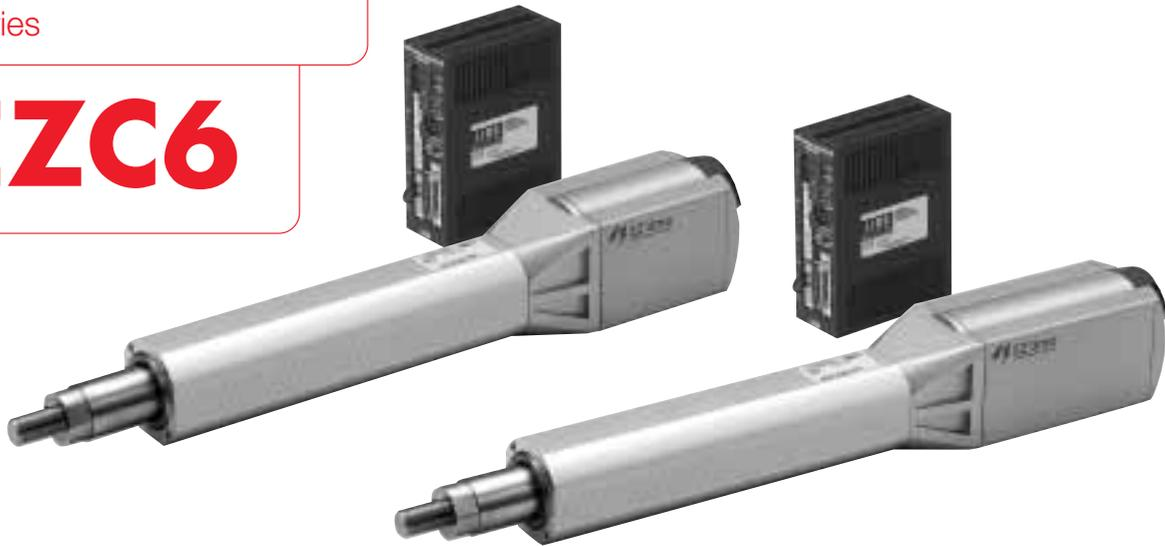

Specifications

Model	Incremental Type		EZC6-□CI				EZC6-□MCI							
	Absolute Type		EZC6-□CA				EZC6-□MCA							
Motor Type	Stepping Motor with Encoder													
Drive Method	Ball Screw													
Electromagnetic Brake	Not equipped					Equipped								
Speed Range	mm/s		~100	~200	~300	~100	~200	~300						
Max. Transportable Mass	kg	Horizontal Direction*	—	—	—	—	—	—						
		Vertical Direction	—	—	—	10	8	3						
Max. Acceleration	m/s ²	Horizontal Direction	—				—							
		Vertical Direction	—				2							
Max. Thrust Force	N	kgf	100	10	94	9.4	35	3.5	100	10	94	9.4	35	3.5
Push Force	N	kgf	100 10 (Speed: 6 mm/s or less)											
Max. Holding Brake Force	N	kgf	Power ON		100		10		100		10			
			Power OFF		—		—		—		—			
			Electromagnetic Brake		—		—		100		10			
Repetitive Positioning Accuracy	mm		±0.02											
Resolution	mm		0.015											
Lead	mm		12											
Stroke	mm		50, 100, 200, 300											
Cylinder Mass	kg		Stroke	50 : 3.2 (3.6)		100 : 3.6 (4.0)		200 : 4.5 (4.9)		300 : 5.5 (5.9)				
Ambient Temperature	°C		0~+40(Nonfreezing)											

*In a horizontal direction, the value cannot be shown because it varies by frictional resistance of the sliding surface.

●See page 52 for the specification and dimensions of the controller.

General Specifications

Item	Specification
Insulation Resistance	100 MΩ minimum when measured by a DC 500 V megger between the following places. • Windings — Case • Case — Windings of electromagnetic brake (Only for electromagnetic brake equipped model)
Dielectric Strength	Sufficient to withstand the following for one minute. • Windings — Case AC 1.0 kV 50 Hz • Case — Windings of electromagnetic brake AC 1.0 kV 50 Hz (Only for electromagnetic brake equipped model)

Cylinder/Controller Combinations

Type	Electromagnetic Brake	Model	Cylinder Model	Controller Model
Incremental Type	Not equipped	EZC6-□CI	EZC6-□	EZMC36I
	Equipped	EZC6-□MCI	EZC6-□M	
Absolute Type	Not equipped	EZC6-□CA	EZC6-□	EZMC36A
	Equipped	EZC6-□MCA	EZC6-□M	

*The box (□) in the model name and cylinder model name represents the code for stroke length.

Push Force

Push force can be set through "Push current setting" in the parameter mode.

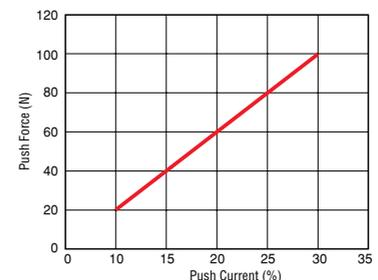

Notes:

• The above value is a reference, not guaranteed.

• When the cylinder is used in a vertical direction, an external force calculated by multiplying the weight of the carried object by the rate of gravitational acceleration is applied. Therefore, the cylinder push force must be set so as to accommodate this external force. Measure the push force using an actual load, and set an appropriate push current.

Correlation Diagram of Speed and Thrust Force

● Horizontal Direction/
Vertical Direction

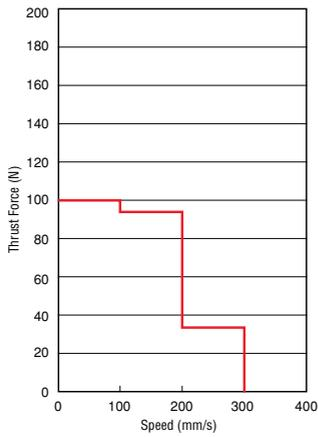

Correlation Diagram of Speed and Load Weight

● Vertical Direction

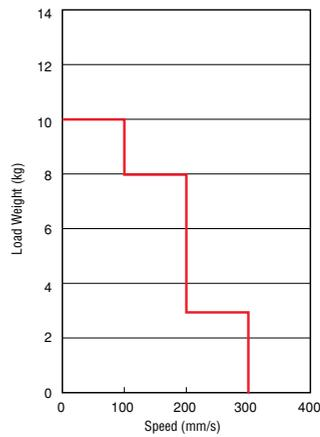

Minimum Positioning Time

Acceleration: 2 m/s² Starting Speed: 6 mm/s

● Horizontal Direction/ Vertical Direction

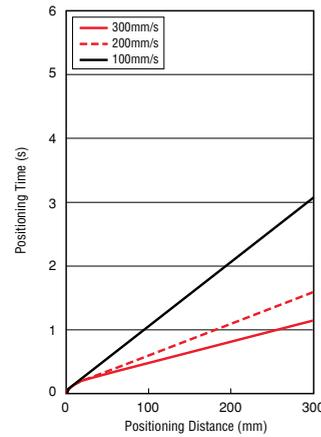

Enlargement of Positioning Distance under 100 mm

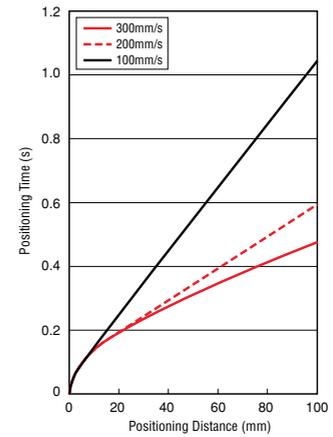

Dimensions unit: mm

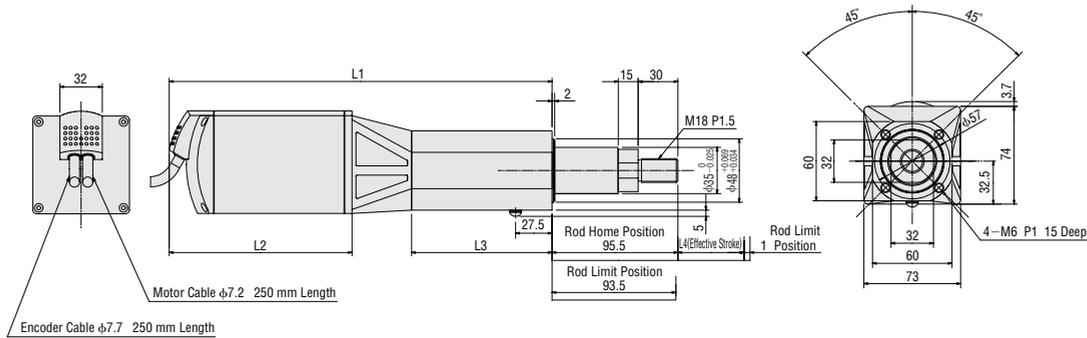

● Nut (included) 1 piece

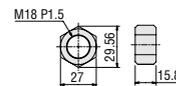

Cylinder Model	L1	L2	L3	L4
EZC6-05	289	138	106	50
EZC6-05M	324	173		
EZC6-10	339	138	156	100
EZC6-10M	374	173		
EZC6-20	439	138	256	200
EZC6-20M	474	173		
EZC6-30	539	138	356	300
EZC6-30M	574	173		

EZHC Series

EZHC4



Specifications

Model	Incremental Type		EZHC4A-□I				EZHC4A-□MI					
	Absolute Type		EZHC4A-□A				EZHC4A-□MA					
Motor Type	Stepping Motor with Built-in Rotor-Position Sensor											
Drive Method	Ball Screw											
Electromagnetic Brake	Not equipped					Equipped						
Speed Range	mm/s		~400		~600		~400		~600			
Max. Transportable Mass	kg	Horizontal Direction*	—		—		—		—			
		Vertical Direction	—		—		6.5		4.5			
Max. Acceleration	m/s ²	Horizontal Direction	—		—		—		—			
		Vertical Direction	—		—		2.5		—			
Max. Thrust Force	N	kgf	65	6.5	55	5.5	65	6.5	55	5.5		
Push Force	N	kgf	65		6.5		(Speed: 6 mm/s or less)					
Max. Holding Brake Force	N	kgf	Power ON		65		6.5		65		6.5	
			Power OFF		—		—		—		—	
		Electromagnetic Brake		—		65		6.5				
Repetitive Positioning Accuracy	mm		±0.02									
Resolution	mm		0.01									
Lead	mm		12									
Stroke	mm		50, 100, 200, 300									
Cylinder Mass	kg		Stroke	50 : 1.7 (1.9)		100 : 2.0 (2.2)		200 : 2.5 (2.7)		300 : 3.0 (3.2)		
Ambient Temperature		°C	0~+40 (Nonfreezing)									

*In a horizontal direction, the value cannot be shown because it varies by frictional resistance of the sliding surface.

●See page 54 for the specification and dimensions of the controller.

General Specifications

Item	Specification
Insulation Resistance	100 MΩ minimum when measured by a DC 500 V megger between the following places. <ul style="list-style-type: none"> Windings — Case Case — Windings of electromagnetic brake (Only for electromagnetic brake equipped model)
Dielectric Strength	Sufficient to withstand the following for one minute. <ul style="list-style-type: none"> Windings — Case AC 1.0 kV 50 Hz Case — Windings of electromagnetic brake AC 1.0 kV 50 Hz (Only for electromagnetic brake equipped model)

Cylinder/Controller Combinations

Type	Electromagnetic Brake	Model	Cylinder Model	Controller Model
Incremental Type	Not equipped	EZHC4A-□I	EZHC4A-□	EZMC13I-A
	Equipped	EZHC4A-□MI	EZHC4A-□M	
Absolute Type	Not equipped	EZHC4A-□A	EZHC4A-□	EZMC13A-A
	Equipped	EZHC4A-□MA	EZHC4A-□M	

*The box (□) in the model name and cylinder model name represents the code for stroke length.

Push Force

Push force can be set through "Push current setting" in the program mode.

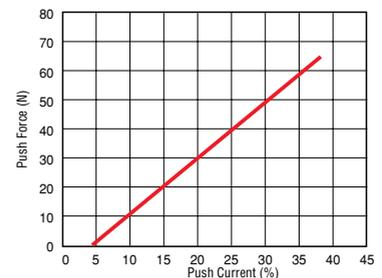

Notes:

• The above value is a reference, not guaranteed.

• When the cylinder is used in a vertical direction, an external force calculated by multiplying the weight of the carried object by the rate of gravitational acceleration is applied. Therefore, the cylinder push force must be set so as to accommodate this external force. Measure the push force using an actual load, and set an appropriate push current.

Correlation Diagram of Speed and Thrust Force

● Horizontal Direction/
Vertical Direction

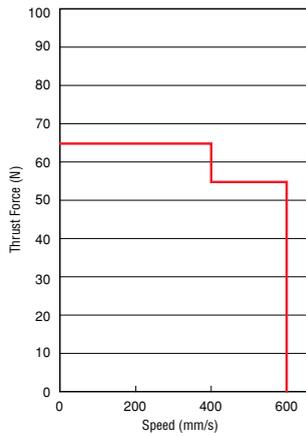

Correlation Diagram of Speed and Load Weight

● Vertical Direction

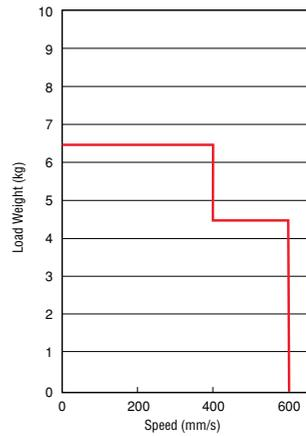

Minimum Positioning Time

Acceleration: 2.5 m/s² Starting Speed: 6 mm/s

● Horizontal Direction/ Vertical Direction

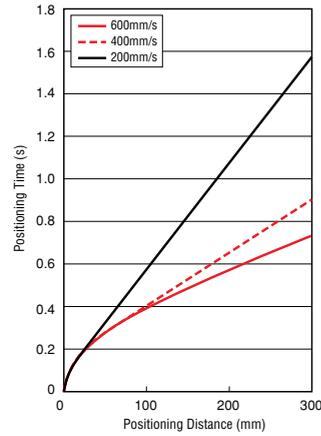

Enlargement of Positioning Distance under 100 mm

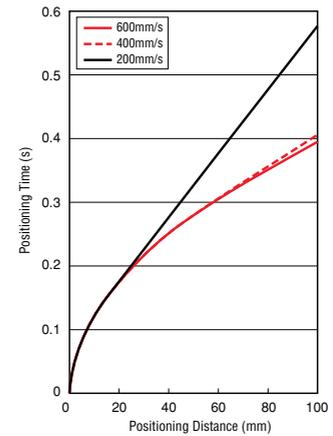

Dimensions unit: mm

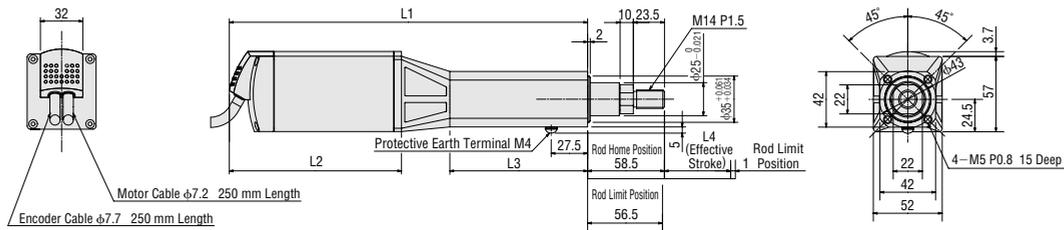

● Nut (included) 1 piece

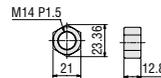

Cylinder Model	L1	L2	L3	L4
EZHC4A-05	270.5	130	104	50
EZHC4A-05M	300.5	160		
EZHC4A-10	320.5	130	154	100
EZHC4A-10M	350.5	160		
EZHC4A-20	420.5	130	254	200
EZHC4A-20M	450.5	160		
EZHC4A-30	520.5	130	354	300
EZHC4A-30M	550.5	160		

EZHC Series

EZHC6



Specifications

Model	Incremental Type		EZHC6A-□I, EZHC6C-□I				EZHC6A-□MI, EZHC6C-□MI				
	Absolute Type		EZHC6A-□A, EZHC6C-□A				EZHC6A-□MA, EZHC6C-□MA				
Motor Type	Stepping Motor with Built-in Rotor-Position Sensor										
Drive Method	Ball Screw										
Electromagnetic Brake	Not equipped					Equipped					
Speed Range	mm/s		~400		~600		~400		~600		
Max. Transportable Mass	kg	Horizontal Direction*	—		—		—		—		
		Vertical Direction	—		—		15		6		
Max. Acceleration	m/s ²	Horizontal Direction	—		—		—		—		
		Vertical Direction	—		—		2.5		—		
Max. Thrust Force	N	kgf	200	20	73	7.3	200	20	73	7.3	
Push Force	N	kgf	200 20 (Speed: 6 mm/s or less)								
Max. Holding Brake Force	N	kgf	Power ON	200		20		200		20	
			Power OFF	—		—		—		—	
			Electromagnetic Brake	—		—		200		20	
Repetitive Positioning Accuracy	mm		±0.02								
Resolution	mm		0.01								
Lead	mm		12								
Stroke	mm		50, 100, 200, 300								
Cylinder Mass	kg		Stroke	50 : 3.3 (3.7)		100 : 3.7 (4.1)		200 : 4.6 (5.0)		300 : 5.6 (6.0)	
Ambient Temperature	°C		0 ~ +40 (Nonfreezing)								

*In a horizontal direction, the value cannot be shown because it varies by frictional resistance of the sliding surface.

●See page 54 for the specification and dimensions of the controller.

General Specifications

Item	Specification
Insulation Resistance	100 MΩ minimum when measured by a DC 500 V megger between the following places. • Windings — Case • Case — Windings of electromagnetic brake (Only for electromagnetic brake equipped model)
Dielectric Strength	Sufficient to withstand the following for one minute. • Windings — Case AC 1.5 kV 50 Hz • Case — Windings of electromagnetic brake AC 1.0 kV 50 Hz (Only for electromagnetic brake equipped model)

Cylinder/Controller Combinations

Type	Electromagnetic Brake	Model	Cylinder Model	Controller Model
Incremental Type	Not equipped	EZHC6A-□I	EZHC6A-□	EZMC24I-A
		EZHC6C-□I	EZHC6C-□	EZMC12I-C
	Equipped	EZHC6A-□MI	EZHC6A-□M	EZMC24I-A
		EZHC6C-□MI	EZHC6C-□M	EZMC12I-C
Absolute Type	Not equipped	EZHC6A-□A	EZHC6A-□	EZMC24A-A
		EZHC6C-□A	EZHC6C-□	EZMC12A-C
	Equipped	EZHC6A-□MA	EZHC6A-□M	EZMC24A-A
		EZHC6C-□MA	EZHC6C-□M	EZMC12A-C

*The box (□) in the model name and cylinder model name represents the code for stroke length.

Push Force

Push force can be set through "Push current setting" in the program mode.

Notes:
 • The above value is a reference, not guaranteed.
 • When the cylinder is used in a vertical direction, an external force calculated by multiplying the weight of the carried object by the rate of gravitational acceleration is applied. Therefore, the cylinder push force must be set so as to accommodate this external force. Measure the push force using an actual load, and set an appropriate push current.

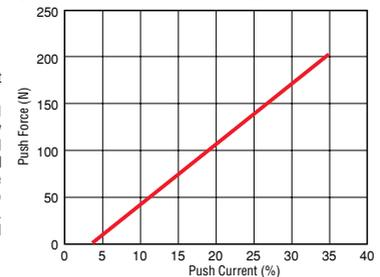

Correlation Diagram of Speed and Thrust Force

● Horizontal Direction/
Vertical Direction

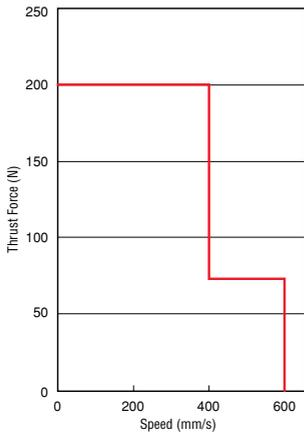

Correlation Diagram of Speed and Load Weight

● Vertical Direction

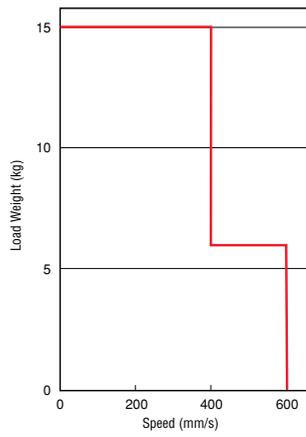

Minimum Positioning Time

Acceleration: 2.5 m/s² Starting Speed: 6 mm/s

● Horizontal Direction/ Vertical Direction

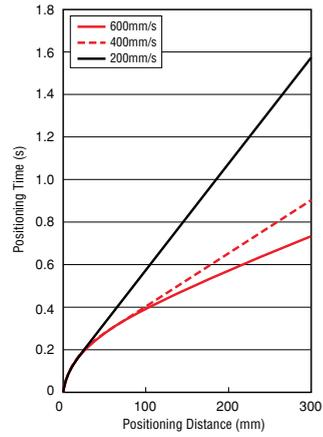

Enlargement of Positioning Distance under 100 mm

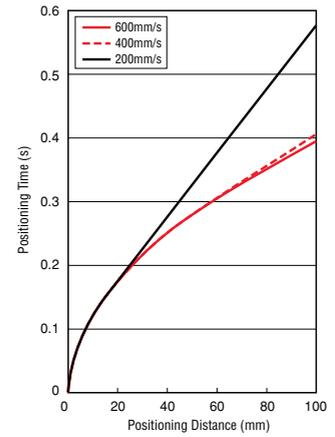

Dimensions unit: mm

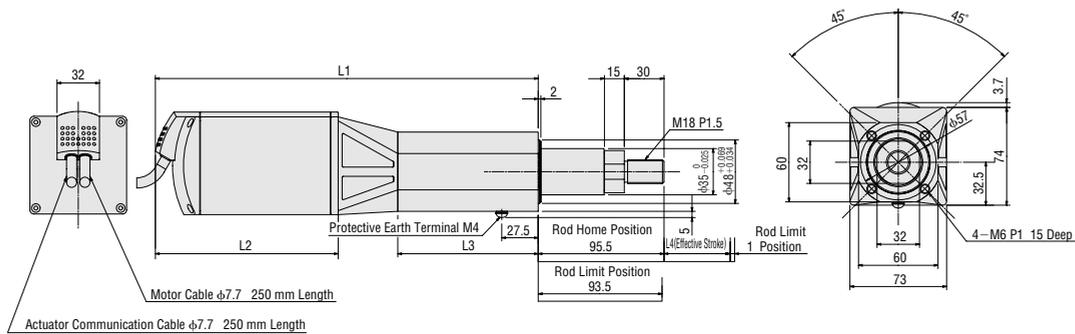

● Nut (included) 1 piece

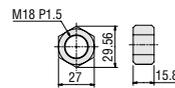

Cylinder Model	L1	L2	L3	L4
EZHC6□-05	289	138	106	50
EZHC6□-05M	324	173		
EZHC6□-10	339	138	156	100
EZHC6□-10M	374	173		
EZHC6□-20	439	138	256	200
EZHC6□-20M	474	173		
EZHC6□-30	539	138	356	300
EZHC6□-30M	574	173		

* Enter the power supply voltage **A** or **C** in the box (□) within the cylinder model name.

EZHP Series

EZHP4



Specifications

Model	Incremental Type		EZHP4A-□I				EZHP4A-□MI				
	Absolute Type		EZHP4A-□A				EZHP4A-□MA				
Motor Type	Stepping Motor with Built-in Rotor-Position Sensor										
Drive Method	Ball Screw										
Electromagnetic Brake	Not equipped					Equipped					
Speed Range	mm/s		~200		~300		~200		~300		
Max. Transportable Mass	kg	Horizontal Direction*	—		—		—		—		
		Vertical Direction	—		—		14		9		
Max. Acceleration	m/s ²	Horizontal Direction	—		—		—		—		
		Vertical Direction	—		—		2.5		—		
Max. Thrust Force	N	kgf	140	14	110	11	140	14	110	11	
Push Force	N	kgf	140 14 (Speed: 6 mm/s or less)								
Max. Holding Brake Force	N	kgf	Power ON		140 14		140 14		—		
			Power OFF		—		—		—		
			Electromagnetic Brake		—		140 14		—		
Repetitive Positioning Accuracy	mm		±0.02								
Resolution	mm		0.01								
Lead	mm		6								
Stroke	mm		50, 100, 200, 300								
Cylinder Mass	kg		Stroke	50 : 1.7 (1.9)		100 : 2.0 (2.2)		200 : 2.5 (2.7)		300 : 3.0 (3.2)	
Ambient Temperature	°C		0 ~ +40 (Nonfreezing)								

*In a horizontal direction, the value cannot be shown because it varies by frictional resistance of the sliding surface.

●See page 54 for the specification and dimensions of the controller.

General Specifications

Item	Specification
Insulation Resistance	100 MΩ minimum when measured by a DC 500 V megger between the following places. • Windings — Case • Case — Windings of electromagnetic brake (Only for electromagnetic brake equipped model)
Dielectric Strength	Sufficient to withstand the following for one minute. • Windings — Case AC 1.0 kV 50 Hz • Case — Windings of electromagnetic brake AC 1.0 kV 50 Hz (Only for electromagnetic brake equipped model)

Cylinder/Controller Combinations

Type	Electromagnetic Brake	Model	Cylinder Model	Controller Model
Incremental Type	Not equipped	EZHP4A-□I	EZHP4A-□	EZMC13I-A
	Equipped	EZHP4A-□MI	EZHP4A-□M	
Absolute Type	Not equipped	EZHP4A-□A	EZHP4A-□	EZMC13A-A
	Equipped	EZHP4A-□MA	EZHP4A-□M	

*The box (□) in the model name and cylinder model name represents the code for stroke length.

Push Force

Push force can be set through "Push current setting" in the program mode.

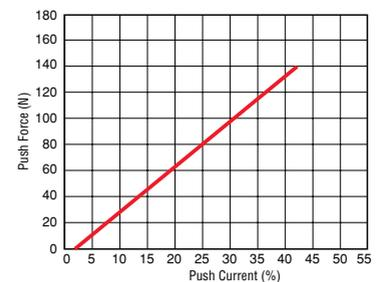

Notes:

• The above value is a reference, not guaranteed.

• When the cylinder is used in a vertical direction, an external force calculated by multiplying the weight of the carried object by the rate of gravitational acceleration is applied. Therefore, the cylinder push force must be set so as to accommodate this external force. Measure the push force using an actual load, and set an appropriate push current.

Correlation Diagram of Speed and Thrust Force

● Horizontal Direction/
Vertical Direction

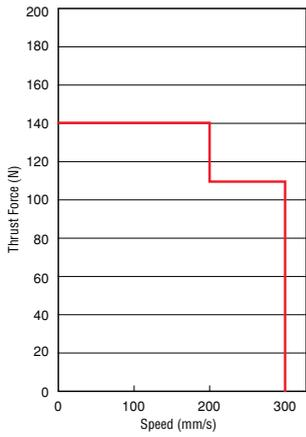

Correlation Diagram of Speed and Load Weight

● Vertical Direction

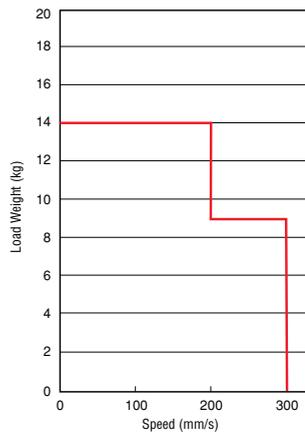

Minimum Positioning Time

Acceleration: 2.5 m/s² Starting Speed: 3 mm/s

● Horizontal Direction/ Vertical Direction

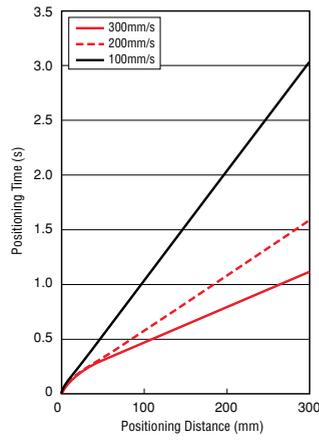

Enlargement of Positioning Distance under 100 mm

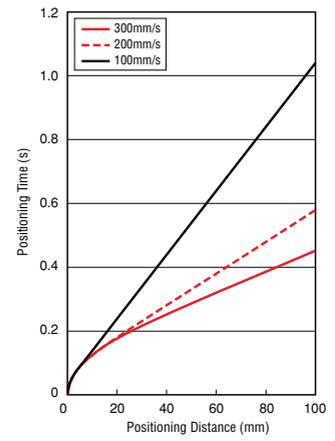

Dimensions unit: mm

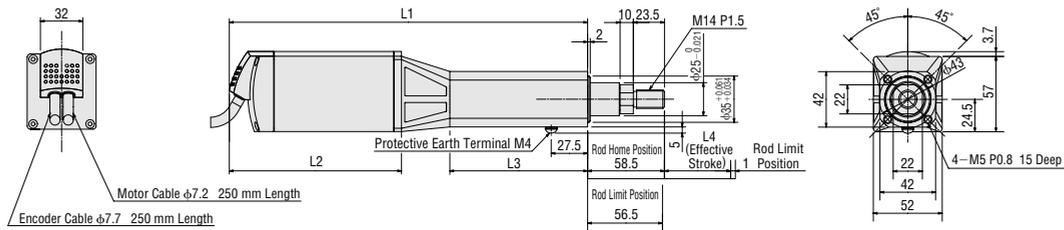

● Nut (included) 1 piece

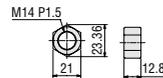

Cylinder Model	L1	L2	L3	L4
EZHP4A-05	270.5	130	104	50
EZHP4A-05M	300.5	160		
EZHP4A-10	320.5	130	154	100
EZHP4A-10M	350.5	160		
EZHP4A-20	420.5	130	254	200
EZHP4A-20M	450.5	160		
EZHP4A-30	520.5	130	354	300
EZHP4A-30M	550.5	160		

EZHP Series

EZHP6



Specifications

Model	Incremental Type		EZHP6A-□I, EZHP6C-□I				EZHP6A-□MI, EZHP6C-□MI				
	Absolute Type		EZHP6A-□A, EZHP6C-□A				EZHP6A-□MA, EZHP6C-□MA				
Motor Type	Stepping Motor with Built-in Rotor-Position Sensor										
Drive Method	Ball Screw										
Electromagnetic Brake	Not equipped					Equipped					
Speed Range	mm/s		~200		~300		~200		~300		
Max. Transportable Mass	kg	Horizontal Direction*	—		—		—		—		
		Vertical Direction	—		—		30		12		
Max. Acceleration	m/s ²	Horizontal Direction	—		—		—		—		
		Vertical Direction	—		—		2.5		—		
Max. Thrust Force	N kgf			400 40		147 14.7		400 40		147 14.7	
		Push Force		N kgf		400 40		400 40		(Speed: 6 mm/s or less)	
Max. Holding Brake Force	N kgf	Power ON		400 40		400 40		400 40		—	
		Power OFF		—		—		—		—	
		Electromagnetic Brake		—		—		400 40		—	
Repetitive Positioning Accuracy	mm				±0.02						
Resolution	mm				0.01						
Lead	mm				6						
Stroke	mm				50, 100, 200, 300						
Cylinder Mass	Figure in the parentheses shows the mass of the model with electromagnetic brake. kg		Stroke	50 : 3.3 (3.7)	100 : 3.7 (4.1)	200 : 4.6 (5.0)	300 : 5.6 (6.0)				
Ambient Temperature	°C				0~+40 (Nonfreezing)						

*In a horizontal direction, the value cannot be shown because it varies by frictional resistance of the sliding surface.

●See page 54 for the specification and dimensions of the controller.

General Specifications

Item	Specification
Insulation Resistance	100 MΩ minimum when measured by a DC 500 V megger between the following places. • Windings — Case • Case — Windings of electromagnetic brake (Only for electromagnetic brake equipped model)
Dielectric Strength	Sufficient to withstand the following for one minute. • Windings — Case AC 1.5 kV 50 Hz • Case — Windings of electromagnetic brake AC 1.0 kV 50 Hz (Only for electromagnetic brake equipped model)

Cylinder/Controller Combinations

Type	Electromagnetic Brake	Model	Cylinder Model	Controller Model
Incremental Type	Not equipped	EZHP6A-□I	EZHP6A-□	EZMC24I-A
		EZHP6C-□I	EZHP6C-□	EZMC12I-C
	Equipped	EZHP6A-□MI	EZHP6A-□M	EZMC24I-A
		EZHP6C-□MI	EZHP6C-□M	EZMC12I-C

*The box (□) in the model name and cylinder model name represents the code for stroke length.

Push Force

Push force can be set through "Push current setting" in the program mode.

Notes:
 • The above value is a reference, not guaranteed.
 • When the cylinder is used in a vertical direction, an external force calculated by multiplying the weight of the carried object by the rate of gravitational acceleration is applied. Therefore, the cylinder push force must be set so as to accommodate this external force. Measure the push force using an actual load, and set an appropriate push current.

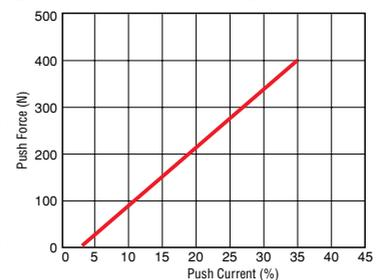

Type	Electromagnetic Brake	Model	Cylinder Model	Controller Model
Absolute Type	Not equipped	EZHP6A-□A	EZHP6A-□	EZMC24A-A
		EZHP6C-□A	EZHP6C-□	EZMC12A-C
	Equipped	EZHP6A-□MA	EZHP6A-□M	EZMC24A-A
		EZHP6C-□MA	EZHP6C-□M	EZMC12A-C

Correlation Diagram of Speed and Thrust Force

● Horizontal Direction/
Vertical Direction

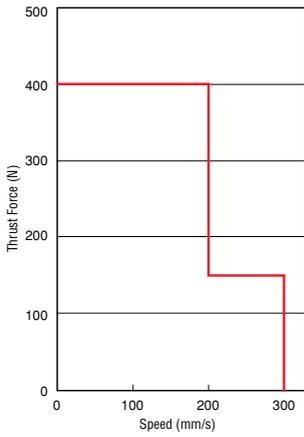

Correlation Diagram of Speed and Load Weight

● Vertical Direction

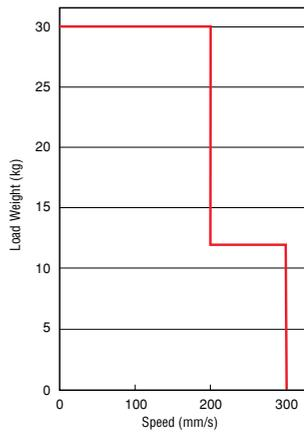

Minimum Positioning Time

Acceleration: 2.5 m/s² Starting Speed: 3 mm/s

● Horizontal Direction/ Vertical Direction

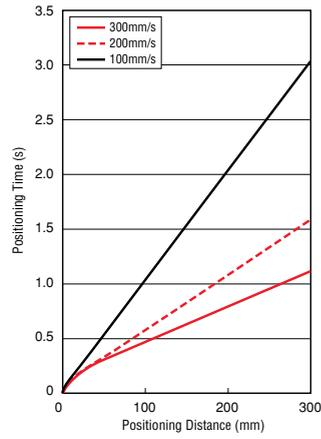

Enlargement of Positioning Distance under 100 mm

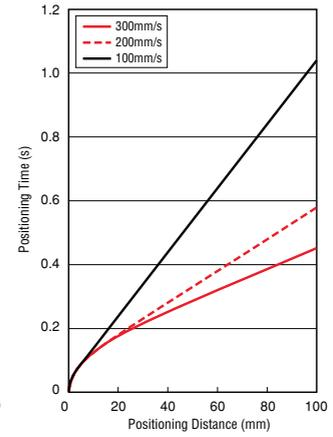

Dimensions unit: mm

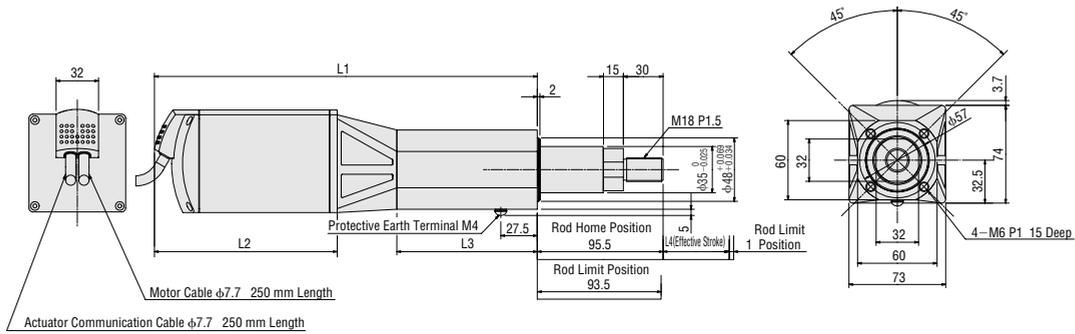

● Nut (included) 1 piece

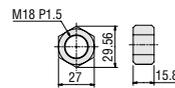

Cylinder Model	L1	L2	L3	L4
EZHP6□-05	289	138	106	50
EZHP6□-05M	324	173		
EZHP6□-10	339	138	156	100
EZHP6□-10M	374	173		
EZHP6□-20	439	138	256	200
EZHP6□-20M	474	173		
EZHP6□-30	539	138	356	300
EZHP6□-30M	574	173		

* Enter the power supply voltage **A** or **C** in the box (□) within the cylinder model name.

EZS and EZC Series

Specifications

Controller Mode

Item	Specification
Type	Stored-data type
Number of Control Axes	1 axis
Maximum Speed	300.000 mm/s
Number of Motion Profiles	63
Positioning Mode	Absolute mode (absolute-position specification) Incremental mode (relative-position specification)
Motion Profile Setting Method	Data is set using the teaching pendant (EZT1) or data editing software (EZED1).
Data Execution Mode	Selective execution / Sequential execution
Travel Amount Setting Range	Absolute mode: -9999.990 to +9999.990 mm (value set in units of 0.015 mm) Incremental mode: -9999.990 to +9999.990 mm (value set in units of 0.015 mm)
Starting Speed	0.015 to 250.000 mm/s (value set in units of 0.015 mm/s) *Data can be set using the teaching pendant or data editing software.
Operating Speed	0.015 to 300.000 mm/s (value set in units of 0.015 mm/s) *Data can be set using the teaching pendant or data editing software.
Acceleration/Deceleration	0.015 to 150.000 m/s ² (value set in units of 0.015 m/s ²) *Data can be set using the teaching pendant or data editing software.
Control Mode	External input mode (EXT) Program mode (PRG) Parameter mode (PAR) Test mode (TST)
Operation Mode	Positioning operation Return-to-home operation Linked operation (a max of 63 profiles) Push-motion operation
Input Signal	24 VDC photocoupler isolated input Input resistance 4.7 Ω
Output Signal	Photocoupler-connected transistor output 24 VDC, 25 mA or less
Power Supply Input	24 VDC ±10% 4.0 A (Controller only: 3.5 A) *Take into account safety margin of +0.2 A for the teaching pendant, and/or +0.3 A for the electromagnetic brake type.
Program Backup	EEPROM

Driver Mode

Item	Specification
Maximum Response Frequency	20 kHz (Pulse Duty 50%)
Pulse-Input Mode mode	Switchable between 1-pulse input mode and 2-pulse input mode (switching via DIP switches on front panel)
Input Signal	5 VDC photocoupler isolated input, input resistance 220 Ω negative logic pulse input (CW Pulse, CCW Pulse) 24 VDC photocoupler isolated input, input resistance 4.7 k Ω (ACL, RUN0~RUN2, STOPO~STOP2, C.OFF)
● CW Pulse Signal	Pulse width 2 μs or more, rise/fall time 2 μs or less (The operation command pulse is input in the 1-pulse input mode.)
● CCW Pulse Signal	Pulse width 2 μs or more, rise/fall time 2 μs or less (The direction of movement is input in the 1-pulse input mode.)
Output Signal	Photocoupler-connected transistor output (The TIM signal uses a photocoupler output.) 24 VDC, 25 mA or less
Power Supply Input	24 VDC ±10% 4.0 A (Controller only: 3.5 A) *Take into account safety margin of +0.2 A for the teaching pendant, and/or +0.3 A for the electromagnetic brake type.

General Specifications

Item	Specification
Insulation Resistance	100 MΩ minimum when measured by a 500 V DC megger between the following places; ● Protective earth terminal – Power input terminal ● Protective earth terminal – Signal input terminal
Dielectric Strength	Sufficient to withstand the following for one minute; ● Protective earth terminal – Power input terminal AC 0.5 kV 50Hz ● Protective earth terminal – Signal input terminal AC 0.5 kV 50Hz
Ambient Temperature	0 °C to +40 °C (nonfreezing)
Ambient Humidity	85% or below (noncondensing)

Battery Specifications (for the absolute type only)

Item	Specification
Battery Type	Cylindrical sealed nickel-cadmium storage cell
Nominal Voltage	1.2 V
Rated Capacity	10000 mAh
Mass	430 g
Life	Approx. 4 years *1
Charge Time	48 hours *1
Data Retention Period *1 *2	Standard backup: Approx. 96 hours Optional backup: Approx. 70 hours
Ambient Temperature	0 °C to +40 °C (nonfreezing)
Ambient Humidity	20 to 85% (noncondensing)

*1 At an ambient temperature of 20°C

*2 After the power is cut off with the battery fully charged

Dimensions unit: mm

Mass: 0.43 kg

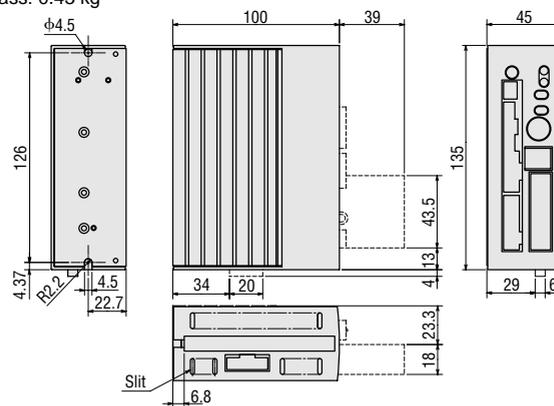

Accessories (common to incremental and absolute type)

I/O Connector Case (1 Piece) 54331-1361 (MOLEX)

I/O Connector (1 Piece) 54306-3619 (MOLEX)

Power Supply Cable (1 Piece) 600 mm

Name	Conductor
+24V	AWG20
GND	AWG20
FG	AWG18

Battery (Supplied with absolute type models. Battery holder provided.)

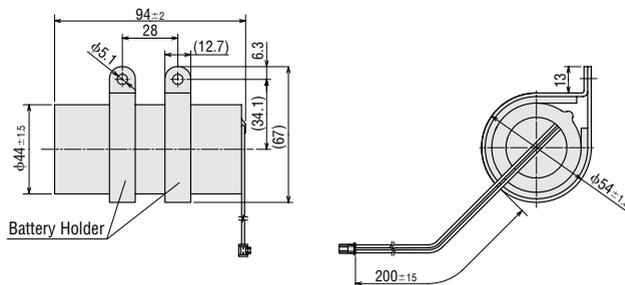

Names and Functions of Parts

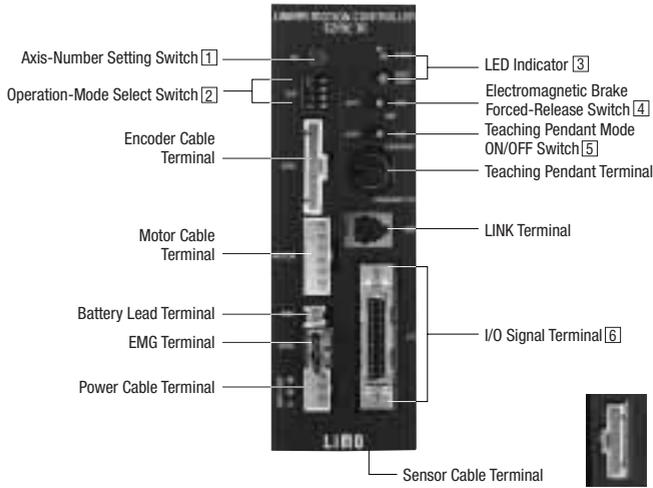

[1] Axis-Number Setting Switch

Display	Function
ID	Set controller axis number

[2] Operation-Mode Select Switch

Display	Function
1	Invalid (not used)
2	
3	Set Pulse Input Mode (in driver mode) ON: 1-Pulse Input Mode OFF: 2-Pulse Input Mode
4	Operation Modes ON: Driver Mode OFF: Controller Mode

ON	OFF
<input type="checkbox"/>	<input type="checkbox"/>
<input type="checkbox"/>	<input type="checkbox"/>
<input type="checkbox"/>	<input type="checkbox"/>
<input type="checkbox"/>	<input type="checkbox"/>

* The area in white indicates the switch position.

* All switches are factory-set to "OFF".

[3] LED Indicator

Display	Color	Name
PWR	Green	Power ON Indicator
RDY/ALM	Green/Red	Status Indicator

[4] Electromagnetic Brake Forced-Release Switch

Display	Function
MB	Switch electromagnetic brake operation modes ON : Actuation OFF: Release

Note: This switch becomes effective only when a protective function is actuated.

[5] Teaching Pendant Mode ON/OFF Switch

Display	Function
PENDANT	Set whether or not the teaching pendant is used ON: Teaching pendant used OFF: Teaching pendant not used

[6] I/O Signals

●Controller Mode

Display	I/O	Terminal Number	Terminal Name	Function		
I/O	Input Signal	23	+COM	Output signal power +24 V		
		25				
		27	COM		Input signal power +24 V	
		28				
		24	-COM			Output signal power GND
		26				
	Output Signal	1	READY	Turns ON when the START input can be received.		
		2	ALM	Turns ON when the EMG input is OFF or upon the occurrence of a controller alarm.		
		4	END	Turns ON when the operation has ended.		
		5	MOVE	Turns ON during operation		
		9	AREA	Turns ON when positioning is performed inside the set area or while the set area is being passed.		
		10	T-UP	Turns ON during push-motion operation (cylinder only).		
		31	ALM0	Alarm information is output in a five-bit code.		
		32	ALM1			
		33	ALM2			
		34	ALM3			
35		ALM4				
Input Signal		36	ACL	Clear an alarm.		
	11	M0	M0 through M5 input signals are combined to select a positioning point. (If all signals are OFF, the sequential positioning mode will be selected.)			
	12	M1				
	13	M2				
	14	M3				
	15	M4				
	16	M5				
	3	STOP	Stop the operation.			
6	START	Start the positioning operation.				
7	PAUSE	Stop the operation temporarily.				
8	HOME	Perform return-to-home operation.				

●Driver Mode

Display	I/O	Terminal Number	Terminal Name	Function		
I/O	Input Signal	23	+COM	Output signal power +24 V		
		25				
		27	COM		Input signal power +24 V	
		28				
		24	-COM			Output signal power GND
		26				
	Output Signal	2	ALM	Turns ON when the EMG input is OFF or upon the occurrence of a controller alarm.		
		4	END	Turns ON when the operation has ended.		
		31	ALM0	Alarm information is output in a five-bit code.		
		32	ALM1			
		33	ALM2			
		34	ALM3			
	35	ALM4				
	21	TIM+	Indicate that the motor is at the initial point of excitation (step [0]). This signal is output once each time the excitation sequence returns to step [0], in synchronism the input pulse. (The circuit is configured so that the excitation sequence completes one cycle when the linear slide table or cylinder rod has moved by 0.24 mm.)			
	22	TIM-				
	Input Signal	36	ACL	Clear an alarm.		
11		RUN0	RUN0 through RUN2 input signals are combined to set the motor operating current.			
12		RUN1				
13		RUN2				
14		STOP0	STOP0 through STOP2 input signals are combined to set the motor standstill current.			
15		STOP1				
16		STOP2				
17		CW+	Move the linear slide table or cylinder rod away from the motor.			
18		CW-				
19		CCW+	Move the linear slide table or cylinder rod toward the motor.			
20	CCW-					
7	C.OFF	When this signal is ON, the current flow to the motor cut off and the holding-brake force generated by the motor torque is lost. Switching this signal from ON to OFF does not change the motor's excitation sequence.				

EZHS, EZHC and EZHP Series

Specifications

Controller Mode

Item	Specification
Type	Stored-data type
Number of Control Axes	1 axis
Maximum Speed	EZHS Series : 800.00mm/s EZHC Series : 600.00mm/s EZHP Series : 300.00mm/s
Number of Motion Profiles	63
Positioning Mode	Absolute mode (absolute-position specification) Incremental mode (Relative-position specification)
Motion Profile Setting Method	Data is set using the teaching pendant (EZT1).
Data Execution Modes	Selective execution / Sequential execution
Travel Amount Setting Range	Absolute mode: -83886.08 to +83886.07 mm (value set in units of 0.01 mm) Incremental mode: -83886.08 to +83886.07 mm (value set in units of 0.01 mm)
Starting Speed	0.01 to 250.00 mm/s (value set in units of 0.01 mm/s) *Data can be set using the teaching pendant.
Operating Speed	0.01 to 800.00 mm/s (value set in units of 0.01 mm/s) *Data can be set using the teaching pendant.
Acceleration/Deceleration	0.01 to 100.00 m/s ² (value set in units of 0.01 m/s ²) *Data can be set using the teaching pendant.
Control Mode	External input mode (EXT) Program mode (PRG) Parameter mode (PAR) Test mode (TST)
Operation Mode	Positioning operation Return-to-home operation Linked operation (a maximum of 4 data) Push-motion operation Continuous operation
Input Signal	24 VDC photocoupler isolated input, input resistance 4.7 k Ω (START, STOP, HOME/PRESET, FREE, MO~M5, REQ, ACL/CK) 5 VDC photocoupler isolated input, input resistance 180 Ω or 24 VDC photocoupler isolated input, input resistance 2.7 k Ω (FWD, RVS)
Output Signal	Photocoupler-connected transistor output 24 VDC, 15 mA or less Line driver output
Power Supply Input	Control Power 24 VDC ± 10%, 1.0 A (Controller only: 0.5 A) *Take into account safety margin of +0.2 A for the teaching pendant, and/or +0.3 A for the electromagnetic brake type.
	Main Power EZMC13(A)-A: AC100 -115V -15%, +10% 50/60Hz 3.3A EZMC24(A)-A: AC100 -115V -15%, +10% 50/60Hz 5.0A EZMC12(A)-C: AC200 -230V -15%, +10% 50/60Hz 3.0A
Program Backup	EEPROM

Driver Mode

Item	Specification
Maximum Response Frequency	80 kHz (Pulse Duty 50%)
Pulse-Input Mode	Switchable between 1-pulse input mode and 2-pulse input mode (switching via DIP switches on front panel) Following mode pulse input (Switched from the teaching pendant)
Input Signal	5 VDC photocoupler isolated input, input resistance 180 Ω or 24 VDC photocoupler isolated input, input resistance 2.7 k Ω, negative logic pulse input (FP, RP) 24 VDC photocoupler isolated input, input resistance 4.7 k Ω (ACL/CK, FREE, C.OFF, PRESET, REQ)
●FP Pulse Signal	Pulse width 2 μs or more, rise/fall time 2 μs or less (The operation command pulse is input in the 1-pulse input mode.)
●RP Pulse Signal	Pulse width 2 μs or more, rise/fall time 2 μs or less (The direction of movement is input in the 1-pulse input mode.)
Output Signal	Photocoupler-connected transistor output 24 VDC, 15 mA or less Line driver output
Power Supply Input	Control Power 24 VDC ± 10%, 1.0 A (Controller only: 0.5 A) *Take into account safety margin of +0.2 A for the teaching pendant, and/or +0.3 A for the electromagnetic brake type.
	Main Power EZMC13(A)-A: AC100 -115V -15%, +10% 50/60Hz 3.3A EZMC24(A)-A: AC100 -115V -15%, +10% 50/60Hz 5.0A EZMC12(A)-C: AC200 -230V -15%, +10% 50/60Hz 3.0A

General Specifications

Item	Specification
Insulation Resistance	100 MΩ minimum when measured by a 500 V DC megger between the following terminals; ●Signal I/O, Control Power supply, PE - Main Power Supply ●Signal I/O, Control Power supply, PE - Motor output ●Signal I/O, Control Power supply, PE - Battery input
Dielectric Strength	Sufficient to withstand the following terminals for one minute; ●Signal I/O, Control Power supply - Main Power Supply 1.8kV ●Signal I/O, Control Power supply - Motor output 1.8kV ●Signal I/O, Control Power supply - Battery input 1.8kV ●PE - Main Power Supply 1.5kV ●PE - Motor output 1.5kV ●PE - Battery input 1.5kV
Ambient Temperature	0 °C to +40 °C (nonfreezing)
Ambient Humidity	85% or below (noncondensing)

Battery Specifications (for the absolute type only)

Item	Specification
Battery Type	Cylindrical sealed nickel-cadmium storage cell
Nominal Voltage	2.4 V
Rated Capacity	2000 mAh
Mass	180 g
Life	Approx. 4 years *1
Charge Time	48 hours *1
Data Retention Period	Approx. 360 hours (15days) *1 *2
Ambient Temperature	0 °C to +40 °C (nonfreezing)
Ambient Humidity	20 to 85% (noncondensing)

*1 At an ambient temperature of 20°C

*2 After the power is cut off with the battery fully charged.

Dimensions unit: mm

Mass: 0.8kg

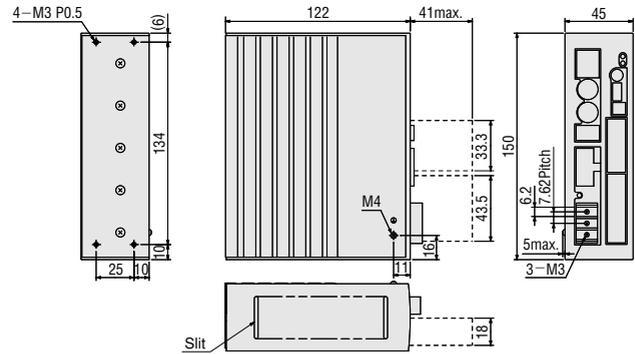

Accessories (common to incremental and absolute type)

Mounting Bracket (2 pieces)

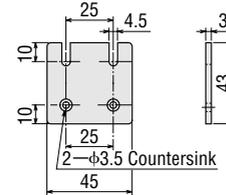

I/O Connector case (1 piece) 54331-1361 (MOLEX)

I/O Connector (1 piece) 54306-3619 (MOLEX)

I/O Connector case for Sensor (1 piece) 54331-1201 (MOLEX)

I/O Connector for Sensor (1 piece) 54306-2019 (MOLEX)

Battery (Supplied with absolute type models. Battery holder provided.)

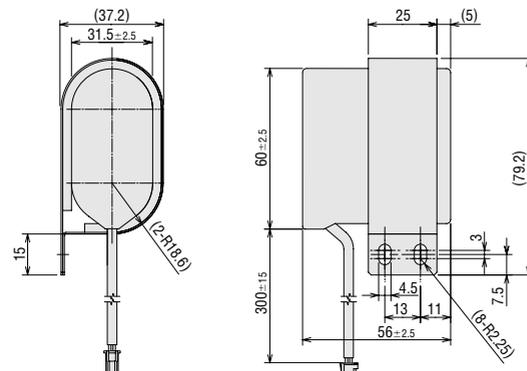

Names and Functions of Parts

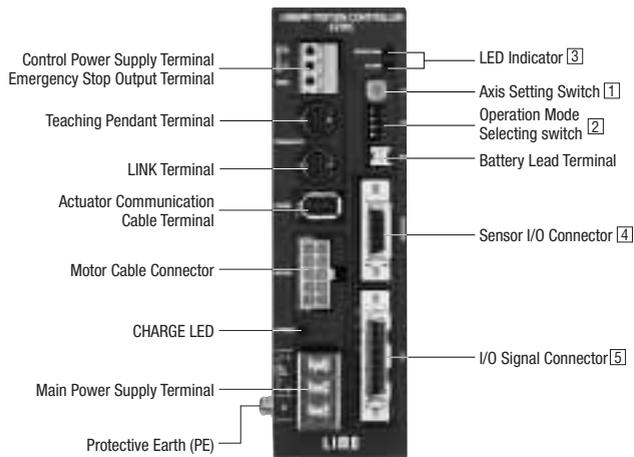

1 Axis-Number Setting Switch

Display	Function
ID	Set controller axis number

2 Operation-Mode Select Switch

Display	Function
4	Invalid (not used)
3	
2	Set Pulse Input Mode (in driver mode) ON: 1-Pulse Input Mode OFF: 2-Pulse Input Mode
1	Operation Modes ON: Driver Mode OFF: Controller Mode

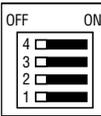

* The area in white indicates the switch position.

* All switches are factory-set to "OFF".

3 LED Indicator

Display	Color	Name
OPERATION	Green	Control power supply indicator
ALARM	Red	Alarm indicator

4 Sensor I/O Connector

Display	I/O	Terminal Number	Terminal Name	Function
SENSOR	Output	1	P24	Power supply for sensor +24V
		11		
		19		
		2	N24	
	12			
	20	Input	13	+LS
14	-LS		-LS (Motor side) limit sensor	
15	HOMELS		Home position sensor	

5 I/O Connector

● Controller Mode

Display	I/O	Terminal Number	Terminal Name	Function	
I/O	Input Signal	18	P24	Power supply for I/O signal +24 V	
		1	N24	Power supply for I/O signal GND	
		19			
	Output Signal	2	ALM	Turns ON when the controller has generated an alarm.	
		3	MOVE	Turns ON during operation.	
		4	END/OUTR	END: Turns ON when the operation has ended. OUTR: Turns ON when current position output is ready.	
		5	AREA/OUTO	AREA: Turns ON when the work has moved to a position inside the specified range or while passing the specified range. OUTO: Outputs the current position.	
		6	T-UP/OUT1	T-UP: Turns ON during push-motion operation. (cylinder only) OUT1: Outputs the current position.	
		20	ASG1(oc)	Outputs the position of the linear slide table or cylinder rod via pulse signal. (Open-collector output)	
		21	BSG1(oc)		
		22	ASG2(dif)		
		23	ASG2(dif)		
		24	BSG2(dif)	Outputs the position of the linear slide table or cylinder rod via pulse signal. (Line-driver output)	
		25	BSG2(dif)		
		Input Signal	7	START	Start positioning operation.
			8	ACL/CK	ACL: Clear the alarm currently present. CK: Used when the current position is output.
			9	FREE	Stop motor excitation and release the electromagnetic brake.
			10	STOP	Stop the operation.
			11	M0	Positioning point is selected via combination of M0 to M5 input signals. (When all signals are OFF, sequential positioning is performed.)
	12		M1		
	13		M2		
	14		M3		
	15		M4		
	16		M5		
	17		HOME/ PRESET*	HOME: Perform return-to-home operation. PRESET: Preset the current position.	
	30		REQ	Request current position output.	
	31		FWD+	Move the linear slide table or cylinder rod to the away from the motor. (Continuous operation input)	
	32		FWD-		
	33		P24-FWD	Move the linear slide table or cylinder rod toward the motor. (Continuous operation input)	
	34		RVS+		
	35	RVS-			
	36	P24-RVS			

* Either HOME or PRESET is available.

● Driver Mode

Display	I/O	Terminal Number	Terminal Name	Function	
I/O	Input Signal	18	P24	Power supply for I/O signal +24 V	
		1	N24	Power supply for I/O signal GND	
		19			
	Output Signal	2	ALM	Turns ON when the controller has generated an alarm.	
		4	END/OUTR	END: Turns ON when the operation has ended. OUTR: Turns ON when current position output is ready.	
		5	TIM/OUTO	TIM: The signal is output every time the excitation sequence returns to the initial stage "0". This signal is output in sync with the input pulse: the signal is output once whenever the excitation sequence returns to step 0. (The excitation sequence completes when the linear slide table or cylinder rod has moved by 0.24 mm*.) * EZHP4/EZHP6 : 0.12 mm OUTO: Outputs the current position.	
		6	OUT1	Outputs the current position	
		20	ASG1(oc)	Outputs the position of the linear slide table or cylinder rod via pulse signal. (Open-collector output)	
		21	BSG1(oc)		
		22	ASG2(dif)		
		23	ASG2(dif)		
		24	BSG2(dif)	Outputs the position of the linear slide table or cylinder rod via pulse signal. (Line-driver output)	
		25	BSG2(dif)		
		Input Signal	8	ACL/CK	ACL: Clear the alarm currently present. CK: Used when the current position is output.
			9	FREE	Stop motor excitation and release the electromagnetic brake.
			10	C.OFF	When this signal turns ON, the current flow to the motor is cut off and the holding-brake force, which is generated by motor torque, will be lost. Turning this signal from ON to OFF does not change the motor's excitation sequence.
			17	PRESET	Preset the current position.
			30	REQ	Request current position output.
			31	FP+	Move the linear slide table or cylinder rod away from the motor. (Pulse input)
	32		FP-		
	33		P24-FP		
	34		RP+	Move the linear slide table or cylinder rod toward the motor. (Pulse input)	
	35		RP-		
	36		P24-RP		

EZS Series • EZC Series

Connection Diagram

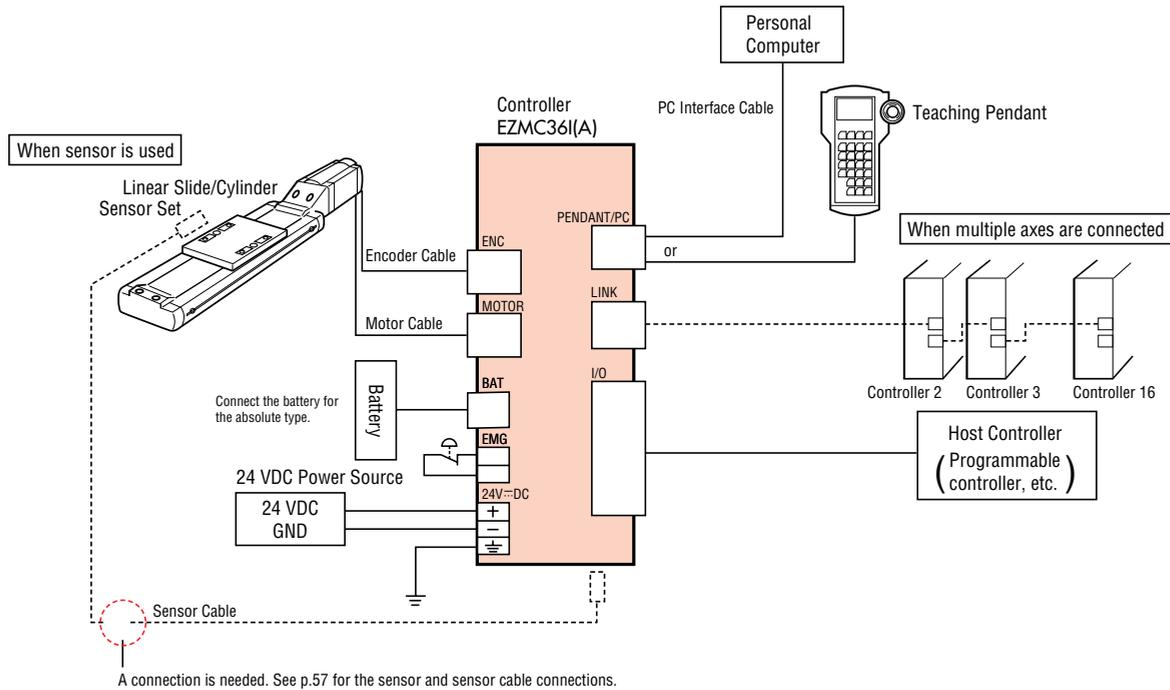

● Power Source

Use a 24 VDC power source with a capacity of 4.0 A or more.
If the power capacity is insufficient, motor output may drop, which may cause the linear slide/cylinder to malfunction (due to lack of thrust force).

● Power Supply to +COM

Use a power source with a capacity of 24 VDC, 100 mA or more.

● Connection of Output Signal

V_0 must be between 5 and 24 VDC.
The current must be 25 mA or less. If the current exceeds 25 mA, connect an external resistance R_0 .

● Notes on Wiring

- Be sure to use an optional motor cable and encoder cable if the linear slide/cylinder will be placed 0.25 m or further away from the controller.
- Wire the control I/O signal lines over as short a distance as possible (max. 2m), using a multiple-core, twisted-pair blanket shield cable [0.08 mm² (AWG 28) or more].
- Wire the control I/O signal lines by providing a minimum distance of 30 cm from the power lines (large-current circuits such as the power supply line and motor line). Do not wire the control I/O signal lines with the power lines in the same duct or bundle them together.

Input Circuit

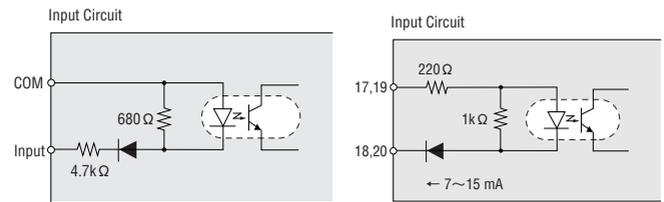

- Controller Mode
- | Pin No. | Signal |
|---------|--------|
| 35 | ACL |
| 11~16 | M0~M5 |
| 3 | STOP |
| 6 | START |
| 7 | PAUSE |
| 8 | HOME |

- Driver Mode
- | Pin No. | Signal |
|---------|-------------|
| 35 | ACL |
| 11~18 | RUN0~RUN2 |
| 14~16 | STOP0~STOP2 |
| 7 | C.OFF |

- Driver Mode
- | Pin No. | Signal |
|---------|--------|
| 17 | CW+ |
| 18 | CW- |
| 19 | CCW+ |
| 20 | CCW- |

Output Circuit

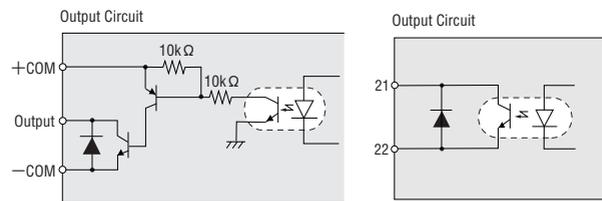

- Controller Mode
- | Pin No. | Signal |
|---------|-----------|
| 1 | READY |
| 2 | ALM |
| 4 | END |
| 5 | MOVE |
| 9 | AREA |
| 10 | T-UP |
| 31~35 | ALM0~ALM4 |

- Driver Mode
- | Pin No. | Signal |
|---------|-----------|
| 2 | ALM |
| 4 | END |
| 31~35 | ALM0~ALM4 |

- Driver Mode
- | Pin No. | Signal |
|---------|--------|
| 21 | TIM+ |
| 22 | TIM- |

■ Connection to Host Computer

● Controller Mode

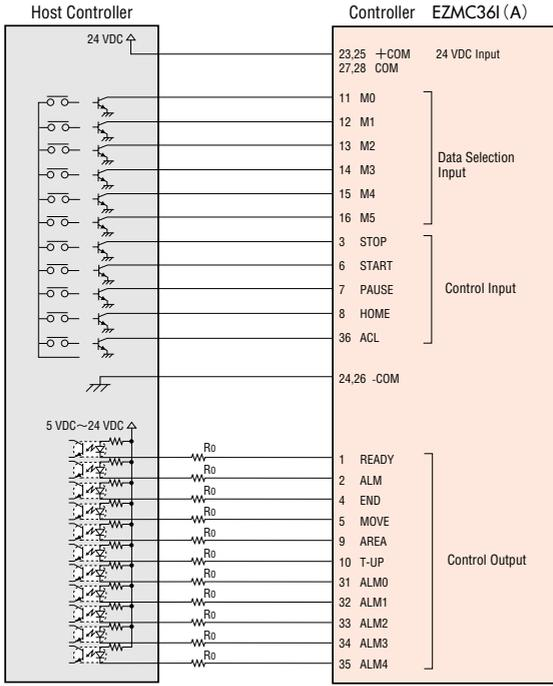

Wiring the Sensors

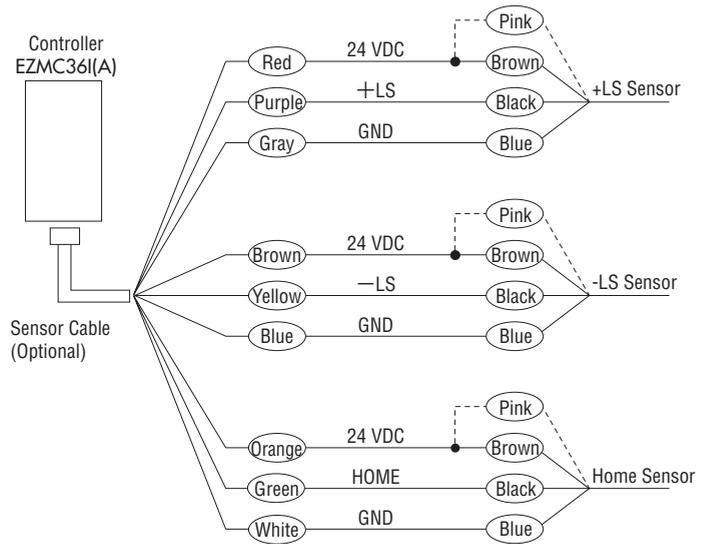

- The 24 VDC output from the controller is used to drive the sensors. Do not use it as a power supply for any item other than the sensors.
- Connect the pink lead to the brown lead when the sensor logic is N.C. (normally closed). The pink lead is not connected when the sensor logic is N.O. (normally open).

● Driver Mode

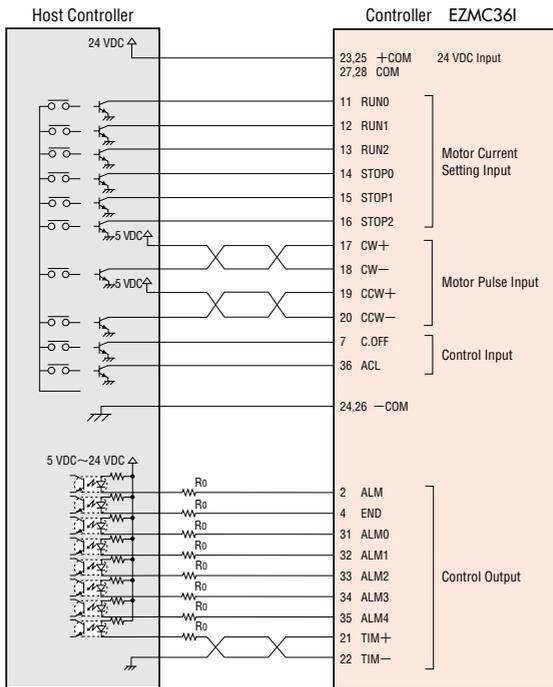

Wiring the Sensors

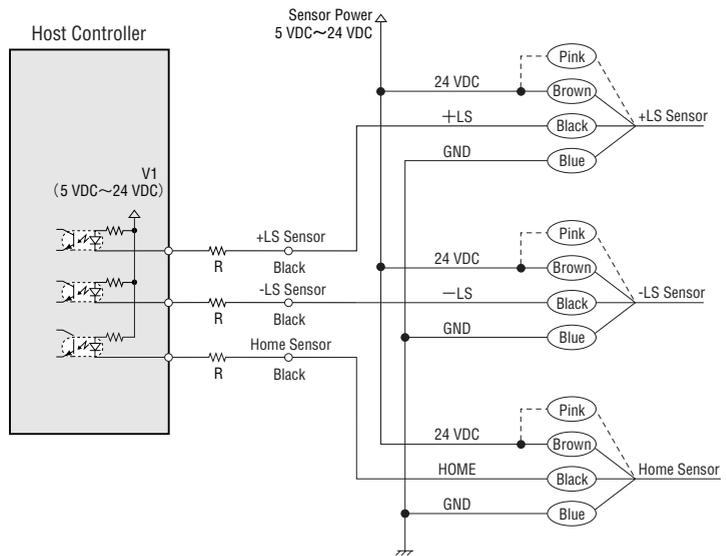

- V1 must be between 5 VDC and 24 VDC. The current must be 100 mA or less. If the current exceeds 100 mA, connect an external resistance R.
- Connect the pink lead to the brown lead when the sensor logic is N.C. (normally closed). The pink lead is not connected when the sensor logic is N.O. (normally open).

EZHS Series • EZHC Series • EZHP Series

■ Connection Diagram

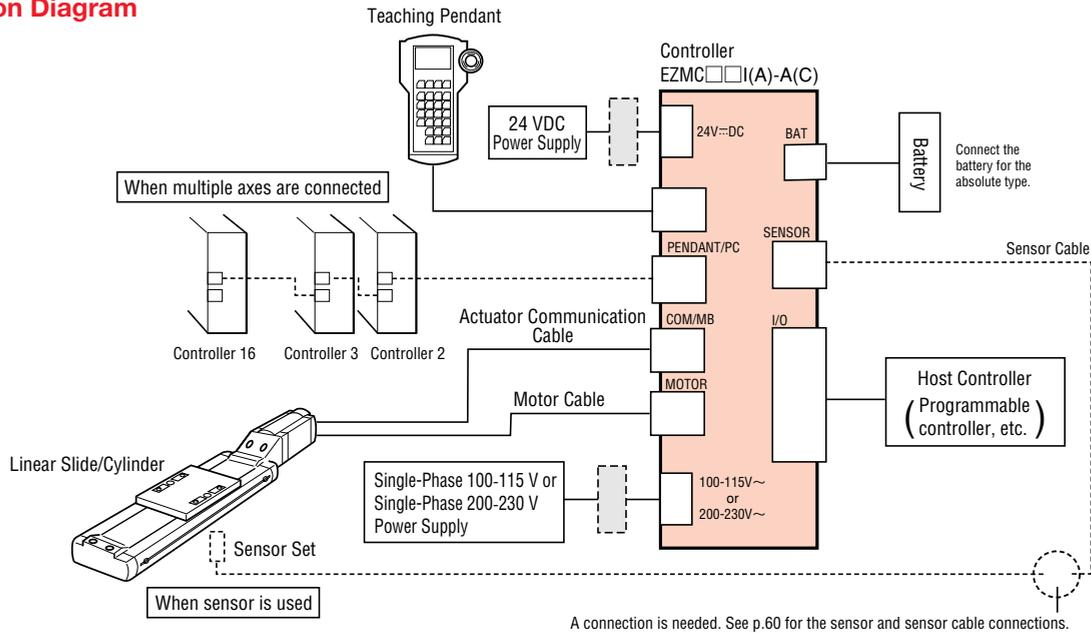

For the section indicated by broken line, see following "Connection Example of Power System and Emergency Stop System".

Connection Example of Power System and Emergency Stop System

A connection example of controller power system and emergency stop system is given below, which conforms to Stop Category 0 under the EN 60204-1 safety standard. See page 15 for details on the applicable standard.

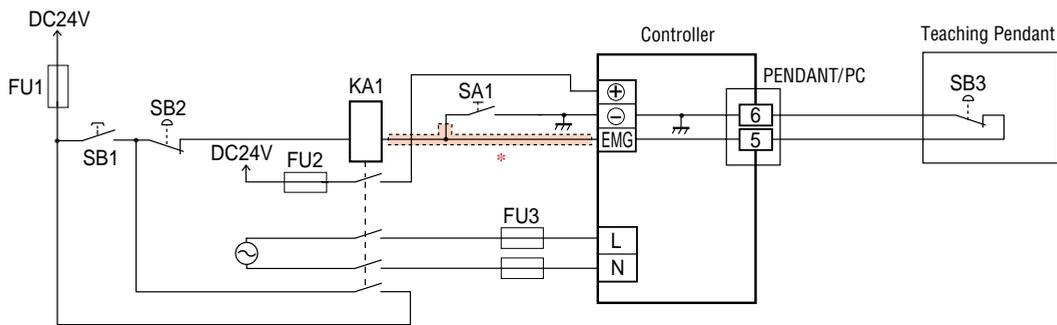

- FU1: Ground-fault protection fuse (500 mA)
- FU2: Ground-fault protection fuse (1 A)
- FU1, FU2, KA1 and SB2 should use EN-certified products.
- Relay (KA1) ratings: 24 VDC/30 mA

- See "EZHS/EZHC/EZHP Series Controller User Manual" for examples of connecting multiple controllers using controller link cables.
- * Provide ground-fault protection in the section indicated by broken line, such as wiring the cables in duct.

● Power Source

Two types of power source, main power and control power, are required. Both power sources must at least have the specified capacity. (See the controller specifications listed on page 54.)

If the power capacity is insufficient, the linear slide/cylinder may not operate normally (due to lack of thrust force) as a result of a drop in motor output.

● Notes on Wiring

- Wire the control I/O signal lines over as short a distance as possible(max.2m), using a multiple-core, twisted-pair blanket shield cable [0.08 mm² (AWG 28) or more].
- Be sure to use an optional motor cable and actuator communication cable if the linear slide/cylinder will be placed 0.25 m or further away from the controller.
- Wire the control I/O signal lines by providing a minimum distance of 30 cm from the power lines (large-current circuits such as the power supply line and motor line). Do not wire the control I/O signal lines with the power lines in the same duct or bundle them together.

● Input Circuit 1 Connection

The power source for P24 must have a capacity of 24 VDC/200 mA or more.

When connecting each sensor to a sensor connector and supplying sensor power from the P24 terminal of the sensor connector, use a DC power source capable of supplying 200 mA as specified above plus the current consumed by each sensor. (When the optional sensor set **PAEZ-S** is used, the current capacity must be increased by 35 mA per sensor.)

The 24 VDC supplied to the P24 terminal of the I/O connector is output to the P24 terminal of the sensor connector as pass-through output.

● Input Circuit 2 Connection

The photocoupler diode in the input circuit can receive 7 to 20 mA of current.

- When a 24 VDC power source is used, connect 24 VDC to ③③ and ③⑤ and then connect to ③② and ③⑤, respectively.
 - When a 5 VDC power source is used, connect 5 VDC to ③① and ③④ and then connect to ③② and ③⑤, respectively.
- If the power source exceeds 5 VDC, connect an external resistor R_2 to keep the input current between 7 to 20 mA.
- If a pulse oscillator of line-driver output is used, connect the + side of line-driver output to ③① and ③④, and the - side of line-driver output to ③② and ③⑤, respectively. (See the connection diagram on page 61.)

● Output Circuit 1 Connection

The load connected to the open-collector output terminal of output circuit 1 should be 30VDC, 10 mA or less. If the current capacity of the load exceeds 10 mA, connect an external resistor R_0 .*

● Output Circuit 2 Connection

The load connected to the open-collector output terminal of output circuit 2 should be 30VDC/15 mA or less. If the current capacity of the load exceeds 15 mA, connect an external resistor R_1 .*

* See page 60 and page 61 for the connection positions of external resistors.

Input Circuit

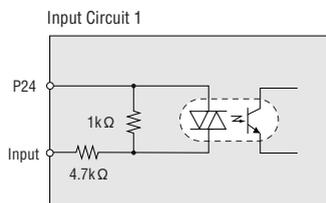

● Controller Mode Pin No.	● Driver Mode Pin No.
⑦ START	⑧ ACL/CK
⑧ ACL/CK	⑨ FREE
⑨ FREE	⑩ C.OFF
⑩ STOP	⑪ PRESET
⑪~⑬ MO~M5	⑫ REQ
⑬ HOME/PRESET	
⑭ REQ	

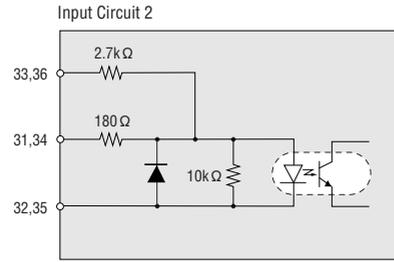

● Controller Mode Pin No.	● Driver Mode Pin No.
③① FWD+	③① FP+
③② FWD-	③② FP-
③③ P24-FWD	③③ P24-FP
③④ RVS+	③④ RP+
③⑤ RVS-	③⑤ RP-
③⑥ P24-RVS	③⑥ P24-RP

Output Circuit

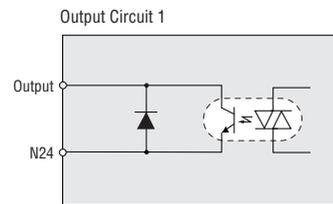

● Controller Mode Pin No.	● Driver Mode Pin No.
② ALARM	② ALARM
③ MOVE	④ END/OUTR
④ END/OUTR	⑤ TIM/OUTO
⑤ AREA/OUTO	⑥ OUT1
⑥ T-UP/OUT1	

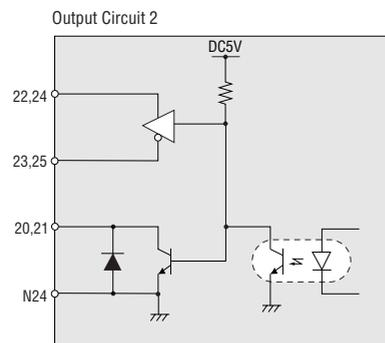

● Common to Controller Model and Driver Mode Pin No.	
⑫ ASG1	A-Phase Pulse Output (Open-Collector Output)
⑬ BSG1	B-Phase Pulse Output (Open-Collector Output)
⑭ ASG2+	A-Phase Pulse Output (Line Driver Output +)
⑮ ASG2-	A-Phase Pulse Output (Line Driver Output -)
⑯ BSG2+	B-Phase Pulse Output (Line Driver Output +)
⑰ BSG2-	B-Phase Pulse Output (Line Driver Output -)

EZHS Series • EZHC Series • EZHP Series

■ Connection to Host Computer

● Controller Mode

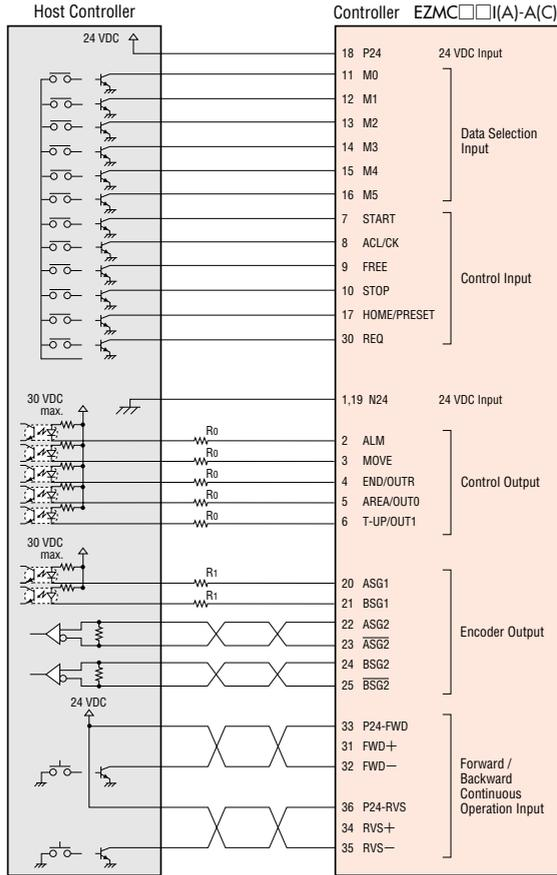

* See page 59 for the conditions of external resistors R_0 and R_1 .

Wiring the Sensors

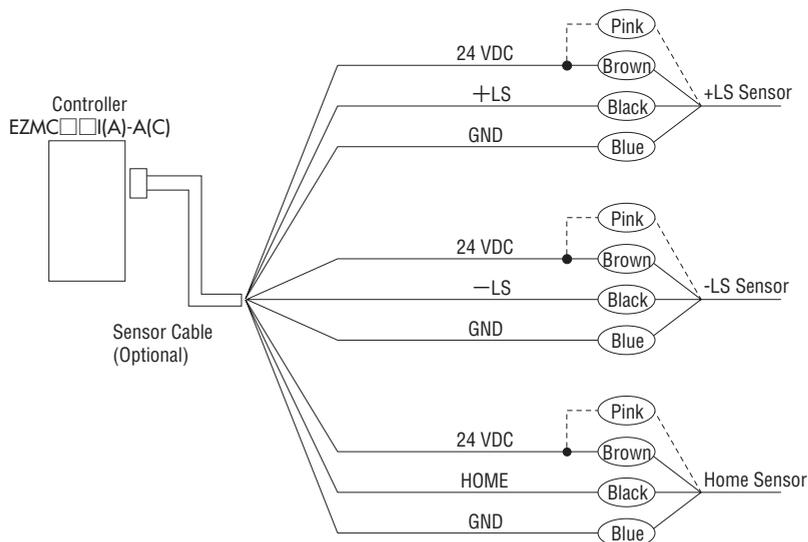

- The 24 VDC output from the controller is used to drive the sensors. Do not use it as a power supply for any item other than the sensors.
- Connect the pink lead to the brown lead when the sensor logic is N.C. (normally closed). The pink lead is not connected when the sensor logic is N.O. (normally open).

● Driver Mode

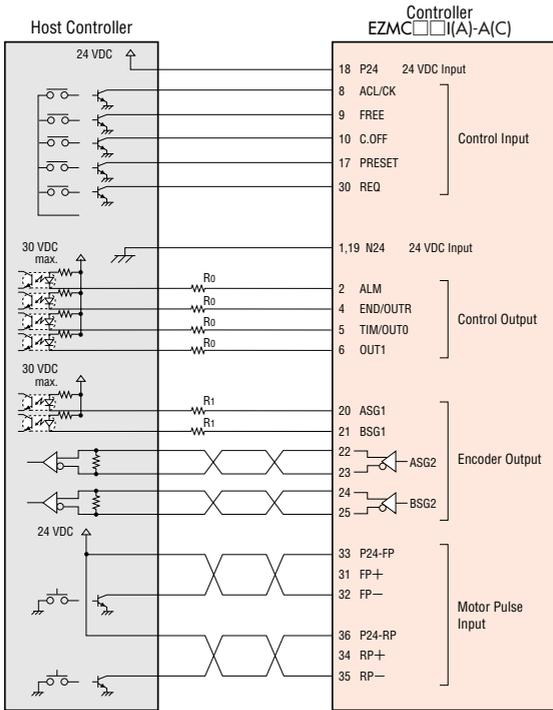

* See page 59 for the conditions of external resistors R_0 and R_1 .

Wiring the Sensors

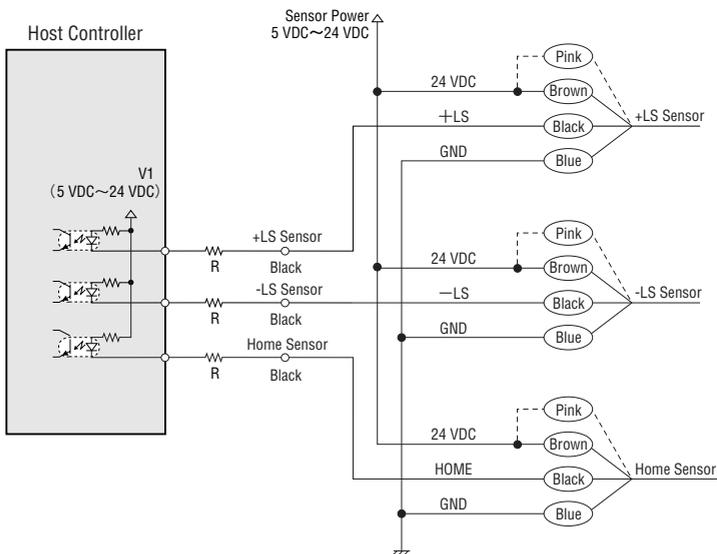

- V1 must be between 5 VDC and 24 VDC. The current must be 100 mA or less. If the current exceeds 100 mA, connect an external resistance R.
- Connect the pink lead to the brown lead when the sensor logic is N.C. (normally closed). The pink lead is not connected when the sensor logic is N.O. (normally open).

■ FWD (FP), RVS (RP) Signals

When connected to a 5 VDC open-collector output signal

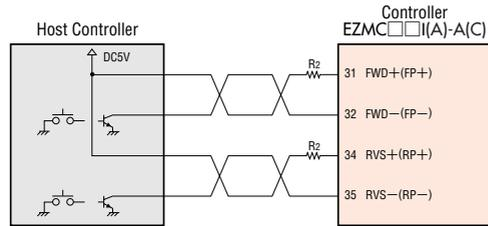

- When the output signal is 5 VDC, the external resistor R_2 is not required. If the output signal exceed 5 VDC, see page 59.

When connected to a 24 VDC open-collector output signal

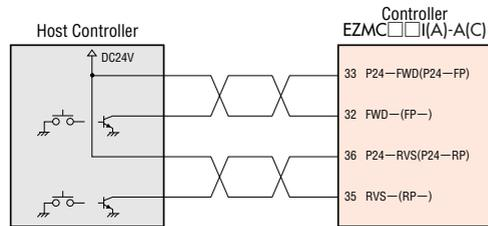

When connected to a line-driver output

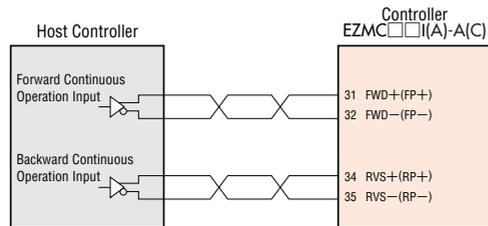

■ Installation of Linear Slide/Cylinder

● Installation Conditions of Linear Slide/Cylinder

Install the linear slide/cylinder in a place satisfying the following conditions. Using the linear slide/cylinder in locations not satisfying these conditions may damage the product.

- Indoor (This product is designed and manufactured for use in equipment as an internal component.)
- An ambient temperature of 0°C to +40°C (nonfreezing)
- A relative humidity of 85% or below (noncondensing)
- A place not exposed to explosive, flammable or corrosive gases
- A well-ventilated place
- A place away from direct sunlight
- A place not subject to dust
- A place not subject to water, oil or other liquids
- A place where the linear slide/cylinder can easily discharge heat
- A place not subject to continuous vibration or excessive shock

● Installation of Linear Slide

◇ Installing the Linear Slide Body

EZS3 and **EZHS3**

Mounting Hole: M4 P0.7, Depth 5 mm
 *Do not use a screw longer than plate thickness +5 mm.

(The number of holes varies, depending on the product. See the dimensions for the applicable products.)

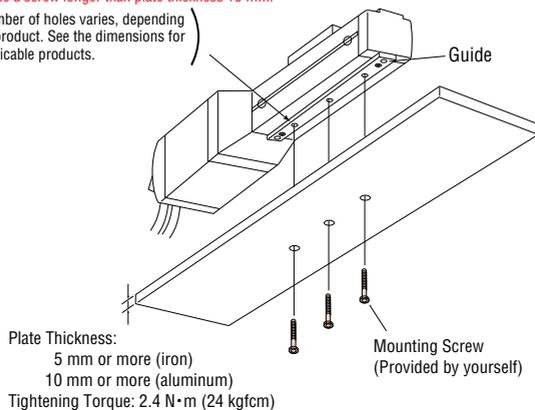

EZS4·EZHS4·EZS6 and **EZHS6**

Mounting Screws (supplied)

EZS4/EZHS4: M5×55 mm 2pcs.

EZS6/EZHS6: M5×75 mm 2pcs.

Mounting Screws (supplied)

EZS4/EZHS4: M5×40 mm 2pcs.

EZS6/EZHS6: M5×55 mm 2pcs.

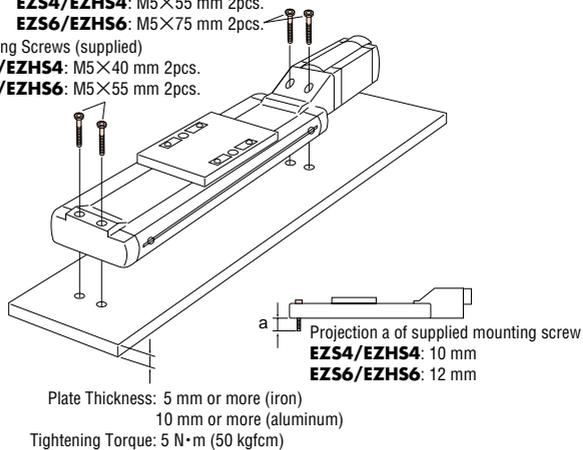

Mounting Hole: M5 P0.8, Depth 6 mm
 *Do not use a screw longer than plate thickness +6 mm.

(The number of holes varies, depending on the product. See the dimensions for the applicable product.)

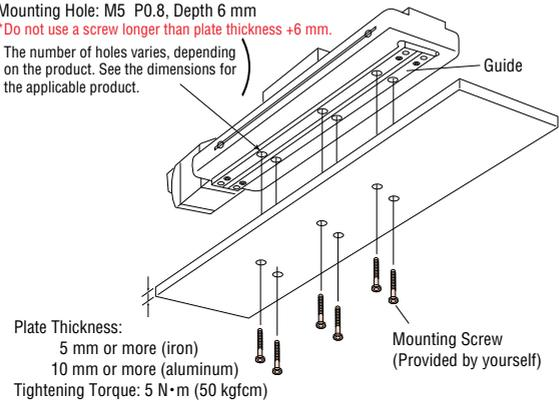

Notes:

- Ensure a parallelism of approx. 0.06 mm (**EZS3, EZHS3:** 0.035 mm) between the mounting surface and mounting plate, and provide a guide of approx. 200 mm long.
- Unless the linear slide is installed horizontally so that load moment is not applied, affix the linear slide using all holes provided in its bottom face.

◇ Installing the Load to the Linear Slide

Four mounting holes are provided in the linear slide table for installation of the work. Use these holes to affix the work.

Load Mounting Holes

EZS3/EZHS3: M4 P0.7, Depth 8 mm

Tightening Torque: 2.4 N·m (24 kgfcm)

EZS4/EZHS4: M4 P0.7, Depth 8 mm

Tightening Torque: 2.4 N·m (24 kgfcm)

EZS6/EZHS6: M5 P0.8, Depth 8 mm

Tightening Torque: 5 N·m (50 kgfcm)

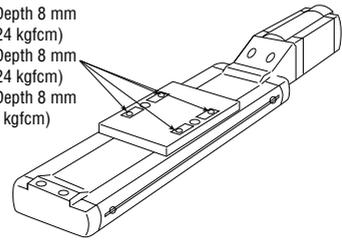

Note: The screws used to affix the load to the table shall not be longer than the thickness of the load by more than 8 mm. If the screw is more than 8 mm longer than the thickness of the load, the screw will contact the side cover of the linear slide.

● Installation of Cylinder

◇ Installing the Cylinder Body

Installation using the mounting holes in the cylinder

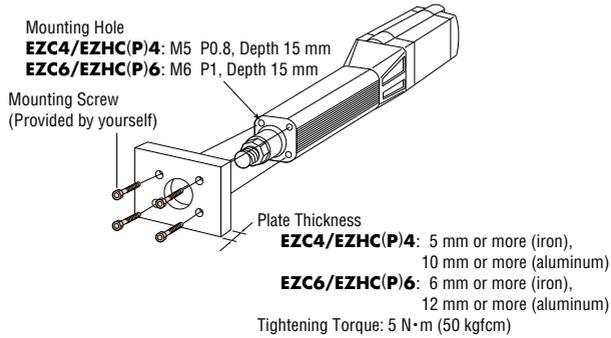

Installation using a cylinder flange **PAEZ□-F** (optional)

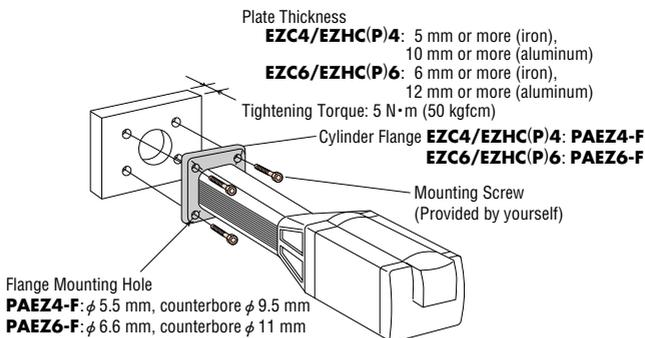

The flange comes with the screws
 for installing the flange to the cylinder.
EZC4/EZHC(P)4: M5×20 mm 4 pcs.
EZC6/EZHC(P)6: M5×25 mm 4 pcs.

◇ Installing the Load to the Cylinder

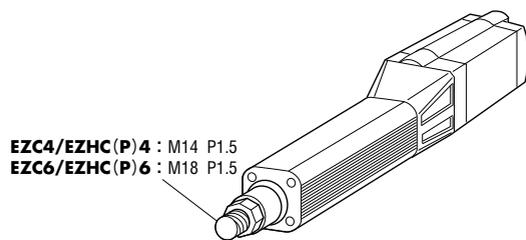

Notes:

• When affixing the load, tighten the screws with the rod locked by a wrench or other appropriate tool so that the rod will not be subjected to angular moment.

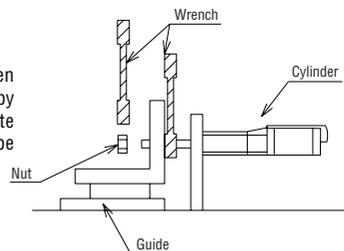

• Provide a guide or other appropriate mechanism to prevent the rod from receiving a load other than in the axial direction.

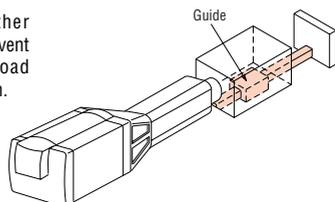

■ Installation of Controller/Battery

● Installation Conditions

Install the controller/battery in a place satisfying the following conditions. Using the controller/battery in locations not satisfying these conditions may damage the product.

- Indoor (This product is designed and manufactured for use in equipment as an internal component.)
- An ambient temperature of 0°C to +40°C (nonfreezing)
- An ambient humidity

Controller: 85% or below (noncondensing)

Battery: 20 to 85% or below (noncondensing)

- A place not exposed to explosive, flammable or corrosive gases
- A place not subject to dust
- A place not subject to water, oil or other liquids
- A place where the controller/battery can easily discharge heat
- A place not subject to continuous vibration or excessive shock

Notes:

- When the controller is installed in an enclosed space such as the interior of a control panel, or near a heat source, always provide ventilation holes to prevent the controller temperature from rising.
- If the installation location is near a vibration source and the controller is subject to vibration, install a shock absorber.
- If a source of significant noise (e.g., a high-frequency welder or large-capacity electromagnetic switch) is located near the controller, provide appropriate measures such as inserting a noise filter, changing the wiring layout and suppressing noise generation.
- Make sure conductive particles (chips, pins, wire offcuts, etc.) will not enter the controller.

● Installation of Battery

EZS and EZC Series

Install the battery using the supplied battery holder in such a way that the recycling mark on the battery nameplate remains visible and by avoiding the protective circuit (see the external view of battery on p.52). The battery may be installed in any orientation, as long as a minimum clearance of 25 mm is provided between the controller and the battery and the battery lead wires can reach the controller.

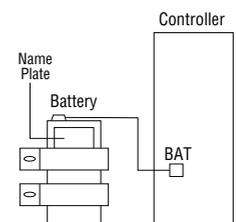

EZHS·EZHC and EZHP Series

Install the battery using the supplied battery holder in such a way that the recycling mark on the battery nameplate remains visible. The battery may be installed in any orientation, as long as a minimum clearance of 25 mm is provided between the controller and the battery and the battery leads can reach the controller.

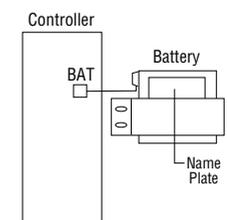

● Installation of Controller

EZS and EZC Series

◇ Installing with Screws

When installing the controller with screws, use the two mounting holes provide on the top and bottom, as shown below.

Use M4 screws and tighten them via a flat washer, etc.

Note: The mounting screws and flat washers are not supplied with the controller. Those items must be provided by the customer.

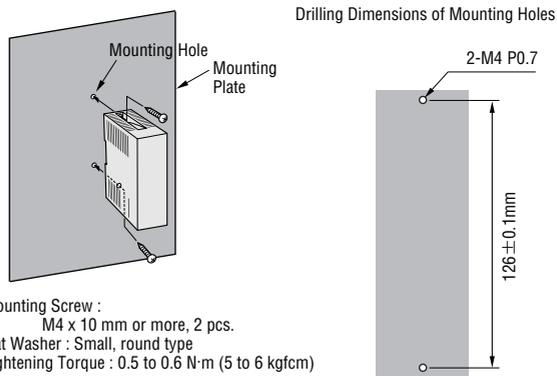

Mounting Screw :
M4 x 10 mm or more, 2 pcs.
Flat Washer : Small, round type
Tightening Torque : 0.5 to 0.6 N·m (5 to 6 kgfcm)

◇ Installing to a DIN Rail

The controller may be installed to a DIN rail using a DIN rail mounting plate **PADP01** (optional).

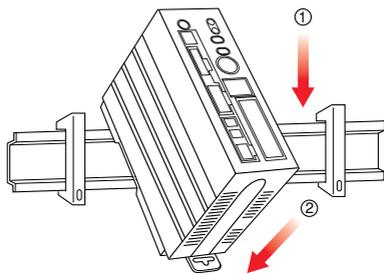

Notes:

- Use a DIN rail with a rail width of 35 mm. Also, use an end plate for affixing the controller.
- The DIN rail and end plate are not supplied with the controller. Those items must be provided by the customer.

◇ Installation Clearances

When two or more controllers are connected, the ambient temperature will increase due to rise in the temperature of each controller. Provide a minimum clearance of 20 mm between the two adjacent controllers and a minimum clearance of 25 mm between each controller and other equipment or structure in all directions.

If the ambient temperature is expected to exceed 40°C, provide forced cooling via a fan.

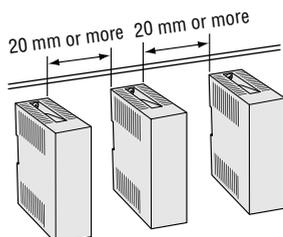

EZHS·EZHC and EZHP Series

◇ Installing using Controller Mounting Brackets

Install the controller mounting brackets over the mounting holes (4 locations) at the back of the controller, using the supplied screws (M3: 4 pieces.)

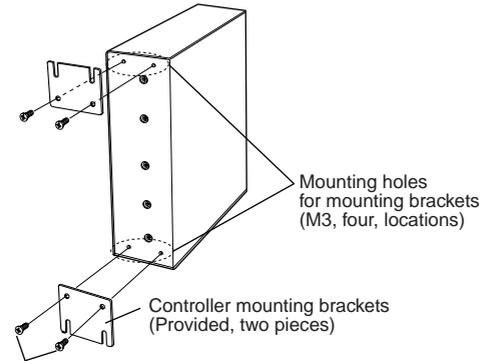

Screws for controller mounting brackets
(Provided, M3, four pieces)
Tightening Torque: 0.5 to 0.6 N·m (5 to 6 kgfcm)

Using the mounting holes in the controller mounting brackets and four screws (M4: not supplied; to be provided by user;), install the controller by making sure no gaps remain along the metal plate.

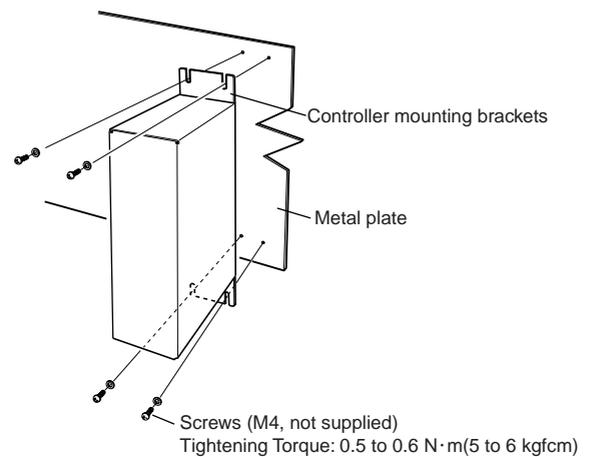

◇ Installation Clearances

When two or more controllers are connected, the ambient temperature will increase due to rise in the temperature of each controller. Provide a minimum clearance of 20 mm between the two adjacent controllers and a minimum clearance of 25 mm between each controller and other equipment or structure in all directions.

If the ambient temperature is expected to exceed 40°C, provide forced cooling via a fan.

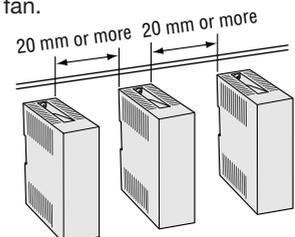

EZS

EZHS

EZC

EZHG

EZHP

Common Can be used with all series.

Used only with the specified series.

Optional Parts (sold separately)

Teaching Pendant **EZT1**

Common

The teaching pendant allows you to set and execute motion profiles, as well as to monitor the set data, current position and I/O status in real time.

Specifications

Display	LCD with 2-colored back light
Cable Length	5 m
Mass	0.37 kg
Ambient Temperature	0°C to +40°C (nonfreezing)

Dimensions unit: mm

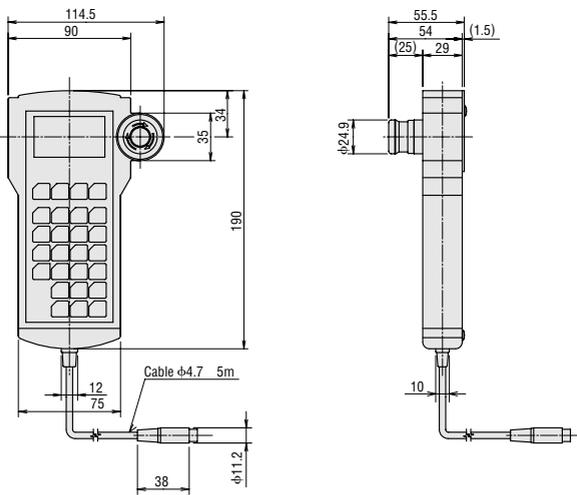

Data Editing Software **EZED1** (with PC Interface Cable)

EZS

EZC

With this software you can set and edit the operation data on a PC. It comes with a PC interface cable for connecting the controller to the PC's RS-232C port. The software also provides various monitoring functions.

* The data editing software can be used with either the **EZMC361** or **EZMC36A** controller.

Specifications

Operating Environment

Model	EZED1
Operating Systems	Microsoft® Windows® 95 Service Pack1 or later *1 Microsoft® Windows® 98 Microsoft® Windows® 98SE Microsoft® Windows® Me Microsoft® Windows NT® 4.0 Service Pack6 or later Microsoft® Windows® 2000 Microsoft® Windows® XP
Computer	A personal computer that can install any of the above Windows® operating systems
Display Resolution	SVGA (800 x 600) or more [XGA (1024 x 768) or more is recommended.]
Hard Disk Capacity	Available disk space of 1.5 MB or more
Disk Drive	CD-ROM drive

*1 Internet Explorer 4.01 Service Pack 1 or later is also required.

• Service Pack signifies a service pack provided by Microsoft Corporation.

• Microsoft, Windows and Windows NT are registered trademarks of Microsoft Corporation in the United States and other countries.

PC Interface Cable

Cable Length	5 m
PC Connector Type	D-sub 9-pin
Communication Port	One RS-232C communication port

Teaching Pendant (**EZT1**)/Data Editing Software (**EZED1**) Function Comparison Table

Item	Teaching pendant	Data editing software
Model	EZT1	EZED1
Cable length	5 m	5 m*1
Display	LCD 17 characters×4 lines	PC screen
Emergency stop switch	●	×
Motion Profile setting	●	●
Parameter setting	●	●
Teaching function (direct/remote)	●	×
Motion Profile execution	●	×
Data copy	×	●
Display function	●	●
Operation data monitoring	●	×

● = Available × = Not available

*1 PC interface cable (supplied) is used.

■ Cable Set

Common

A set of dedicated cables is used to connect the **EZ limo** linear slide/cylinder with the controller.

The cable set consists of a motor cable and an encoder cable. The cable length can be selected from 2 m, 5 m and 10 m. Each of the cables can be purchased individually. The same cable can be used for both the electromagnetic brake type and non-electromagnetic brake type.

Model	Length (L)	Applicable Products
CC02EZ1	2m	EZS Series EZC Series
CC05EZ1	5m	
CC10EZ1	10m	
CC02EZ2	2m	EZHS Series EZHC Series EZHP Series
CC05EZ2	5m	
CC10EZ2	10m	

● Individual Motor Cable

Model	Length (L)	Applicable Products
CC02EZ1-M	2m	EZS Series EZC Series
CC05EZ1-M	5m	
CC10EZ1-M	10m	
CC02EZ2-M	2m	EZHS Series EZHC Series EZHP Series
CC05EZ2-M	5m	
CC10EZ2-M	10m	

● Individual Encoder Cable, Actuator Communication Cable

Type of Cable	Model	Length (L)	Applicable Products
Encoder Cable	CC02EZ1-E	2m	EZS Series EZC Series
	CC05EZ1-E	5m	
	CC10EZ1-E	10m	
Actuator Communication Cable	CC02EZ1-T	2m	EZHS Series EZHC Series EZHP Series
	CC05EZ1-T	5m	
	CC10EZ1-T	10m	

● Dimensions unit: mm

Motor Cable

CC□□EZ1-M

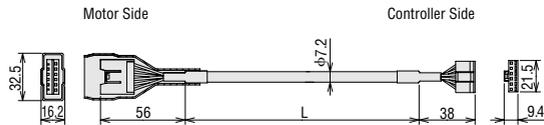

CC□□EZ2-M

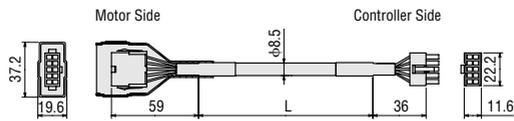

Encoder Cable

CC□□EZ1-E



Actuator Communication Cable

CC□□EZ1-T



■ Flexible Cable Set

Common

Use flexible cables in applications where the cables will flex repeatedly.

As with the cable set, flexible cables are available in three lengths of 2 m, 5 m and 10 m. The cables may be purchased individually or as a set.

The same cable can be used for both the electromagnetic brake type and non-electromagnetic brake type.

Model	Length (L)	Applicable Products
CC02EZ1R	2m	EZS Series EZC Series
CC05EZ1R	5m	
CC10EZ1R	10m	
CC02EZ2R	2m	EZHS Series EZHC Series EZHP Series
CC05EZ2R	5m	
CC10EZ2R	10m	

● Individual Flexible Motor Cable

Model	Length (L)	Applicable Products
CC02EZ1R-M	2m	EZS Series EZC Series
CC05EZ1R-M	5m	
CC10EZ1R-M	10m	
CC02EZ2R-M	2m	EZHS Series EZHC Series EZHP Series
CC05EZ2R-M	5m	
CC10EZ2R-M	10m	

● Individual Flexible Encoder Cable, Flexible Actuator Communication Cable

Type of Cable	Model	Length (L)	Applicable Products
Flexible Encoder Cable	CC02EZ1R-E	2m	EZS Series EZC Series
	CC05EZ1R-E	5m	
	CC10EZ1R-E	10m	
Flexible Actuator Communication Cable	CC02EZ1R-T	2m	EZHS Series EZHC Series EZHP Series
	CC05EZ1R-T	5m	
	CC10EZ1R-T	10m	

Common Can be used with all series.

EZS **EZHS** **EZC** **EZHC** **EZHP** Used only with the specified series.

● **Dimensions** unit: mm

Flexible Motor Cable

CC□□EZ1R-M

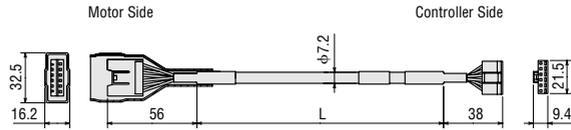

CC□□EZ2R-M

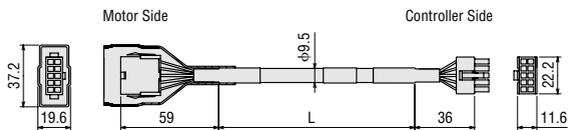

Flexible Encoder Cable

CC□□EZ1R-E

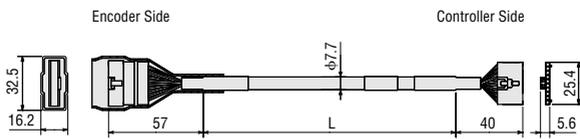

Flexible Actuator Communication Cable

CC□□EZ1R-T

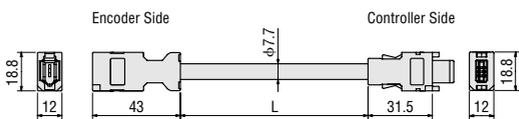

■ **Controller Link Cable**

Common

Use these dedicated cables to link the **EZ limo** controllers.

Model	Length (L)	Applicable Products
CC002EZ1-L	0.2m	EZS Series EZC Series
CC002EZ2-L	0.2m	EZHS Series EZHC Series EZHP Series

● **Dimensions** unit: mm

CC002EZ1-L

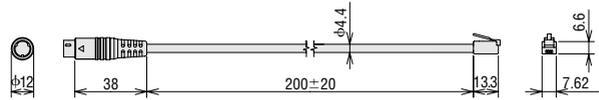

CC002EZ2-L

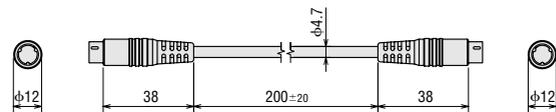

■ **I/O Cable**

Common

These cables are used exclusively for connection between the **EZ limo** controller and the host controller.

A half-pitch connector allowing one-touch connection to the controller is attached at one end of the flat cable.

Model	Length (L)
CC36D1-1	1m
CC36D2-1	2m

● **Dimensions** unit: mm

Conductor: AWG28

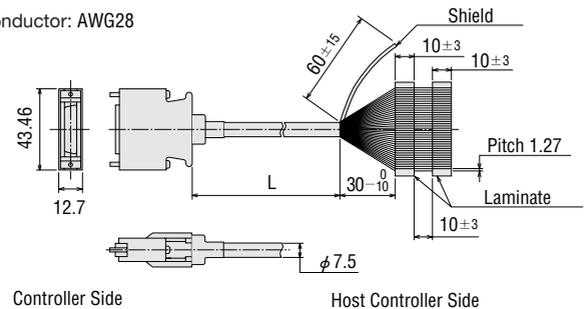

■ **Sensor Cable**

Common

Use these cables to connect the sensors used in the controller mode to the controller.



Model	Length (L)	Applicable Products
CC02EZ1-S	2m	EZS Series EZC Series
CC20D1-1	1m	EZHS Series EZHC Series
CC20D2-1	2m	EZHP Series

■ Sensor Set PAEZ-S

Common

These sensors can be used in the controller mode or driver mode. The sensor set consists of three sets of a sensor, a sensor mounting bracket and a cable with connector. The fittings, screws and other parts needed for installation are also provided.

* In the driver mode, connect the sensors to the controller you have provided.

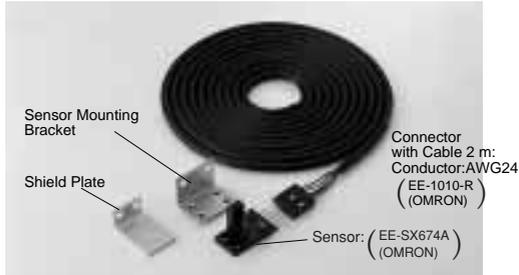

● Specifications

Model	EE-SX674A (Omron)
Power Supply	5 to 24 VDC ± 10%, ripple (P-P) 10% or less
Current Consumption	35 mA or less
Control Output	NPN open-collector output, 5 to 24 VDC, 100 mA or less Residual voltage 0.8 V or less (at load current of 100 mA)
Indicator Lamp	Detection display (red)
Sensor Logic	Normal open/Normal closed (switchable, depending on connection)

● Connection Example (controller mode)

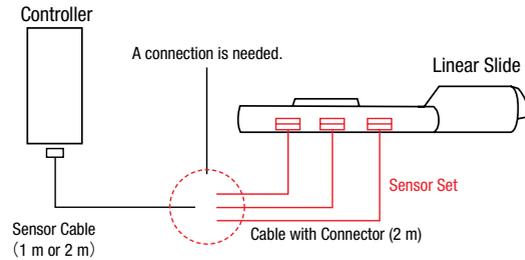

● Example of Sensor Installation (for the linear slide only)

EZS3·EZHS3

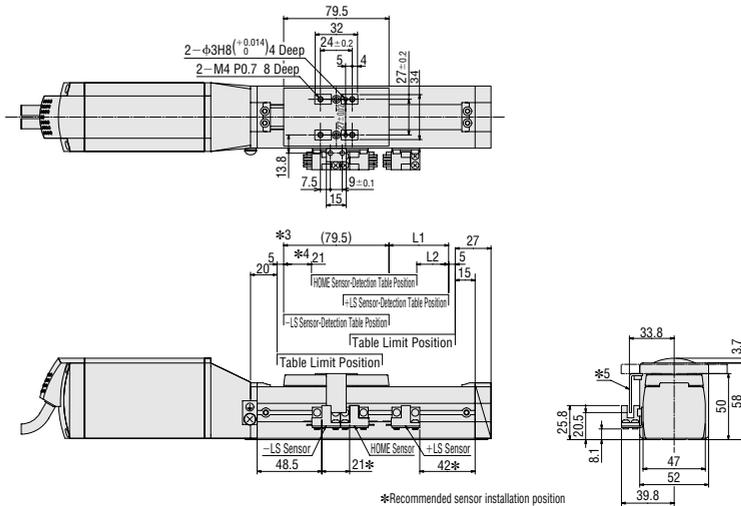

Linear Slide Model	*1	*2	
	L1	L2	
EZS3-05	EZHS3A-05	45	—
EZS3-10	EZHS3A-10	95	74
EZS3-15	EZHS3A-15	145	124
EZS3-20	EZHS3A-20	195	174
EZS3-25	EZHS3A-25	245	224
EZS3-30	EZHS3A-30	295	274
EZS3-40	EZHS3A-40	395	374
EZS3-50	EZHS3A-50	495	474

*1 L1 indicates the effective stroke when two sensors are used.
*2 L2 indicates the effective stroke when three sensors are used.
The EZS3-05 (M) and EZHS3-05 (M) do not accommodate the use of three sensors.
*3 Home position when two sensors are used.
*4 Home position when three sensors are used.
*5 Install the shield plate onto the work.
(Use the two supplied mounting screws: M3 x 5 mm.)

EZS4·EZHS4

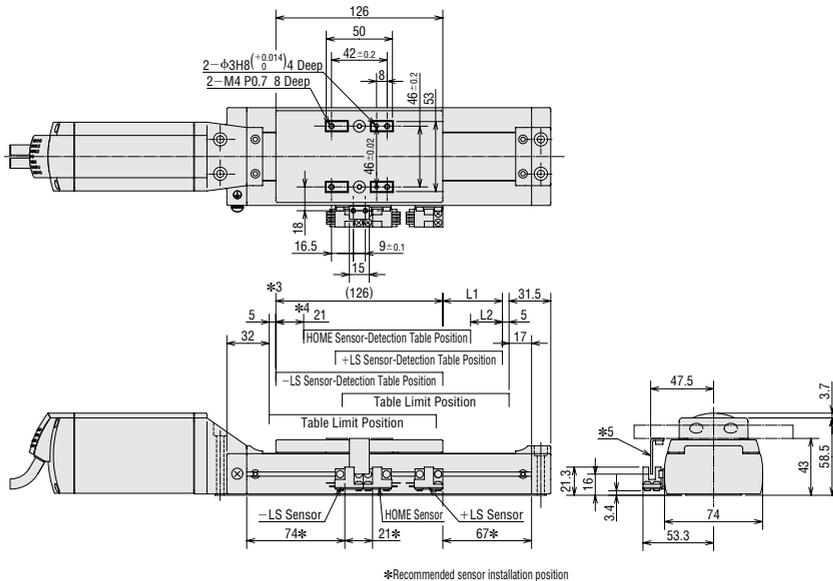

Linear Slide Model	*1	*2	
	L1	L2	
EZS4-05	EZHS4A-05	45	—
EZS4-10	EZHS4A-10	95	74
EZS4-15	EZHS4A-15	145	124
EZS4-20	EZHS4A-20	195	174
EZS4-25	EZHS4A-25	245	224
EZS4-30	EZHS4A-30	295	274
EZS4-40	EZHS4A-40	395	374
EZS4-50	EZHS4A-50	495	474

*1 L1 indicates the effective stroke when two sensors are used.
*2 L2 indicates the effective stroke when three sensors are used.
The EZS4-05 (M) and EZHS4-05 (M) do not accommodate the use of three sensors.
*3 Home position when two sensors are used.
*4 Home position when three sensors are used.
*5 Install the shield plate onto the work.
(Use the two supplied mounting screws: M3 x 5 mm.)

Common Can be used with all series.

EZS EZHS EZC EZHC EZHP Used only with the specified series.

EZS6, EZHS6

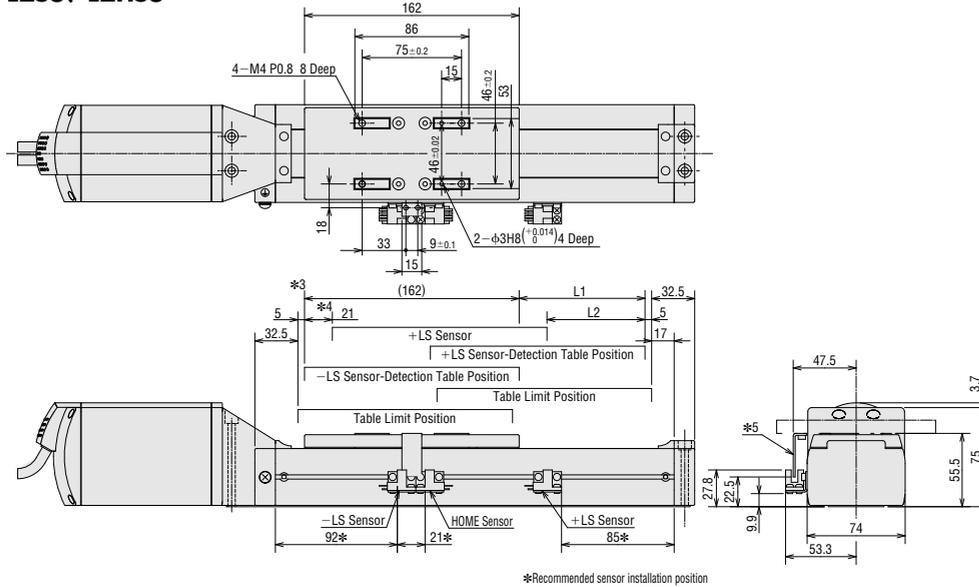

Linear Slide Model		*1	*2
		L1	L2
EZS6-10	EZHS6-10	95	74
EZS6-10M	EZHS6-10M		
EZS6-15	EZHS6-15	145	124
EZS6-15M	EZHS6-15M		
EZS6-20	EZHS6-20	195	174
EZS6-20M	EZHS6-20M		
EZS6-25	EZHS6-25	245	224
EZS6-25M	EZHS6-25M		
EZS6-30	EZHS6-30	295	274
EZS6-30M	EZHS6-30M		
EZS6-40	EZHS6-40	395	374
EZS6-40M	EZHS6-40M		
EZS6-50	EZHS6-50	495	474
EZS6-50M	EZHS6-50M		

*1 L1 indicates the effective stroke when two sensors are used.
 *2 L2 indicates the effective stroke when three sensors are used.
 *3 Home position when two sensors are used.
 *4 Home position when three sensors are used.
 *5 Install the shield plate onto the work.
 (Use the two supplied mounting screws: M3 x 5 mm.)

Dual Axis Mounting Bracket

EZS EZHS

This dual axis mounting bracket allows easy installation of a pair of linear slides. Various types of brackets are available to support combinations of X-Y and X-Z axes.

Installation Example

Use **EZS6** or **EZHS6** for the X-axis and **EZS4** or **EZHS4** (stroke: 50 to 300 mm) for the Y- or Z-axis.

X-Y Configuration

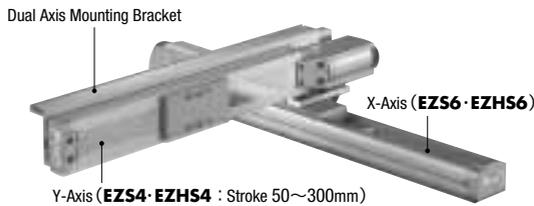

X-Y Bracket

Y-Axis Stroke	Model
50mm	PAB-EZ64Y05
100mm	PAB-EZ64Y10
150mm	PAB-EZ64Y15
200mm	PAB-EZ64Y20
250mm	PAB-EZ64Y25
300mm	PAB-EZ64Y30

X-Z Configuration

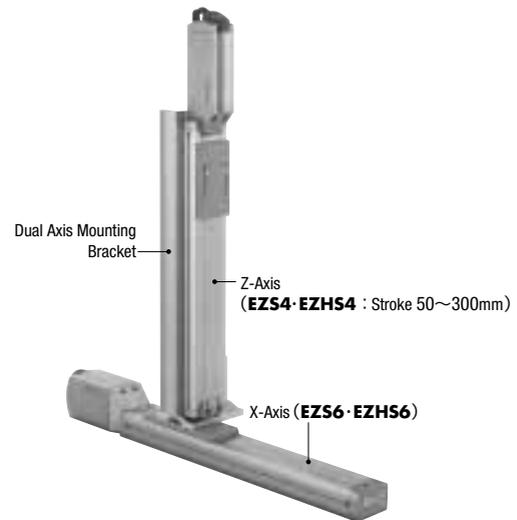

X-Z Bracket

Z-Axis Stroke	Model
50mm	PAB-EZ64Z05
100mm	PAB-EZ64Z10
150mm	PAB-EZ64Z15
200mm	PAB-EZ64Z20
250mm	PAB-EZ64Z25
300mm	PAB-EZ64Z30

◇ Maximum Transportable Mass in Dual Axis Configuration

● Maximum Transportable Mass in X-Y Configuration

Unit: kg

Applicable Products	Speed Range		Y-Axis Stroke					
	X-Axis	Y-Axis	50mm	100mm	150mm	200mm	250mm	300mm
EZS	300mm/s	300mm/s	4.3	4.0	3.6	3.3	3.0	2.6
	200mm/s	300mm/s	5.0					
		200mm/s	10.0		9.2	7.8	6.6	5.6
EZHS	800mm/s	800mm/s	13.5	11.1	9.2	7.8	6.6	5.6

◇ Dimensions unit: mm

X-Y Configuration 1

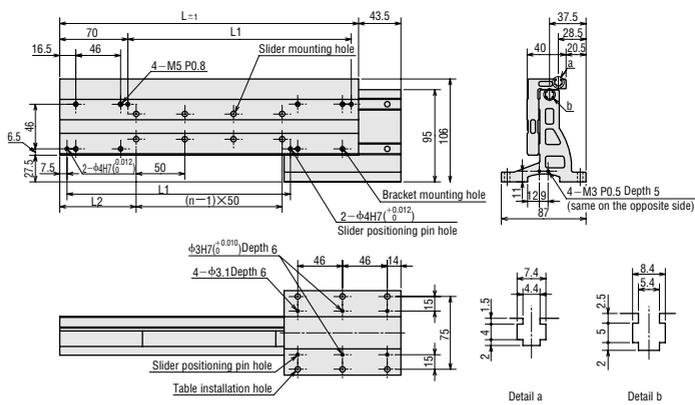

X-Z Configuration 1

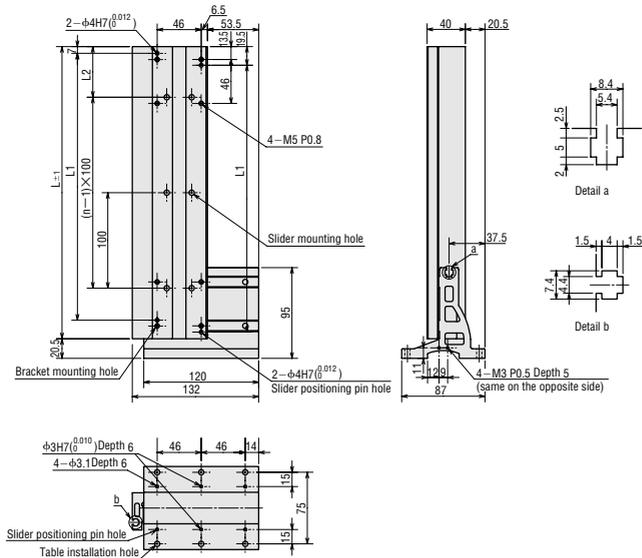

X-Y Configuration 2

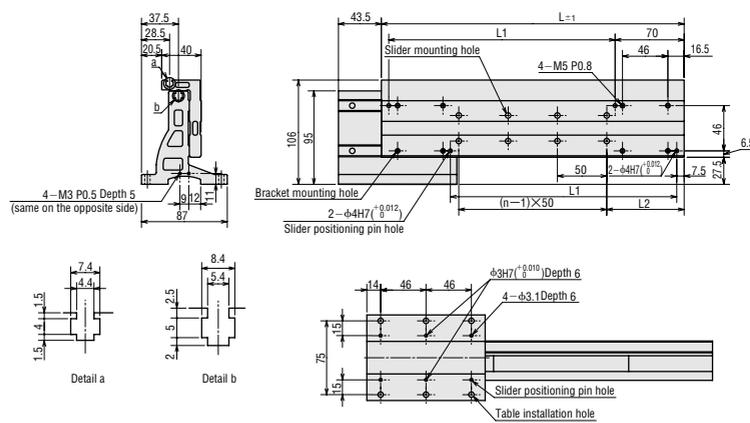

X-Z Configuration 2

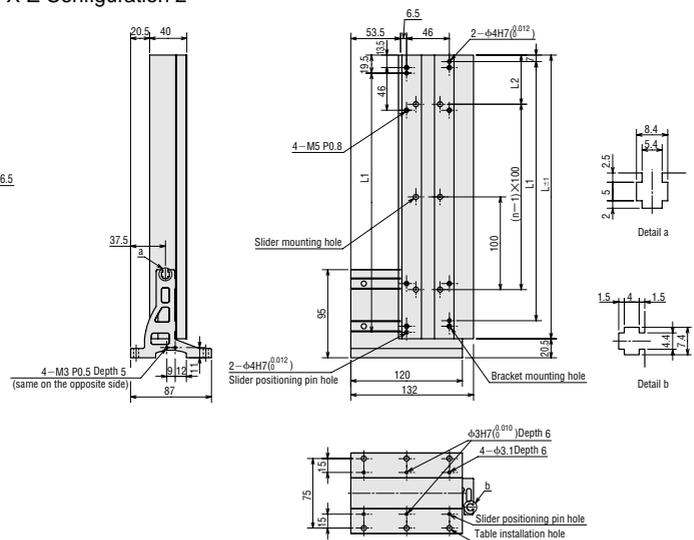

Model	L	L1	L2	n	Mass(kg)
PAB-EZ64Y05	307	229.5	78.5	4	1.62
PAB-EZ64Y10	357	279.5	53.5	6	1.75
PAB-EZ64Y15	407	329.5	78.5	6	1.88
PAB-EZ64Y20	457	379.5	53.5	8	2.01
PAB-EZ64Y25	507	429.5	78.5	8	2.14
PAB-EZ64Y30	557	479.5	53.5	10	2.27

Model	L	L1	L2	n	Mass(kg)
PAB-EZ64Z05	256	229.5	78	2	1.51
PAB-EZ64Z10	306	279.5	53	3	1.64
PAB-EZ64Z15	356	329.5	78	3	1.78
PAB-EZ64Z20	406	379.5	53	4	1.91
PAB-EZ64Z25	456	429.5	78	4	2.05
PAB-EZ64Z30	506	479.5	53	5	2.18

Common Can be used with all series.

EZS **EZHS** **EZC** **EZHC** **EZHP** Used only with the specified series.

◇ Operating Range unit: mm

X-Y Configuration Pattern 1

*The Y-axis can be installed symmetrically to the X-axis either on its right or left. The moving range is the same on both sides.

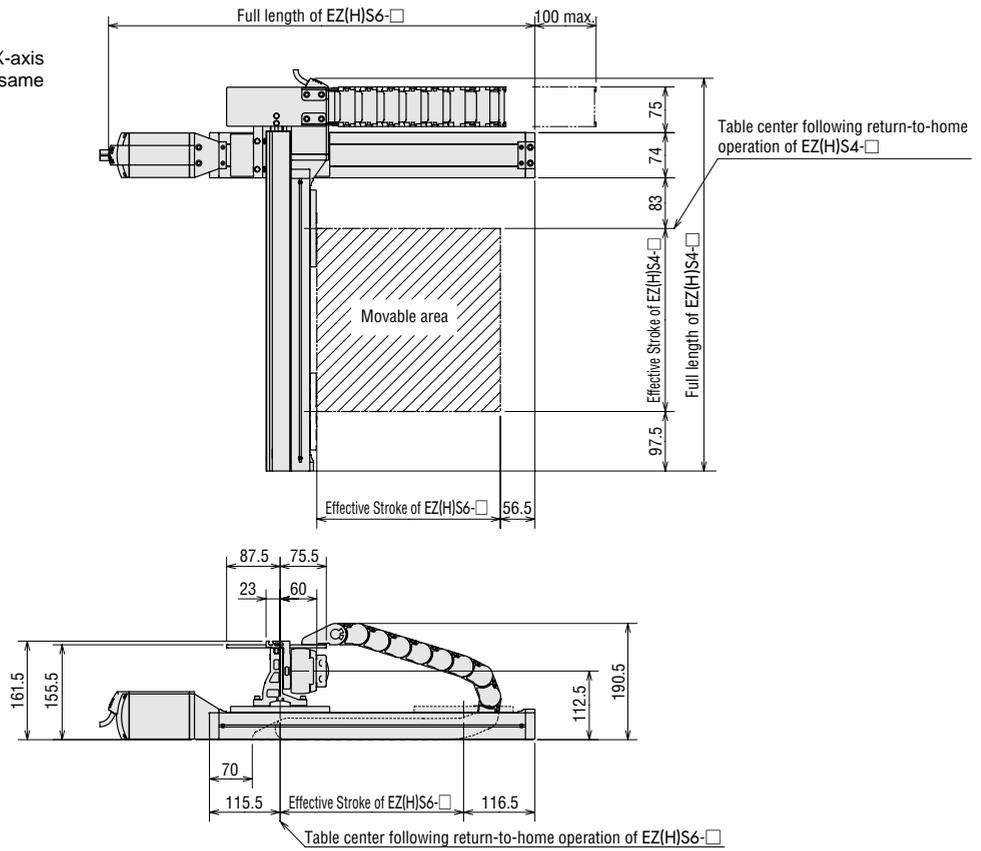

X-Y Configuration Pattern 2

*The Y-axis can be installed symmetrically to the X-axis either on its right or left. The moving range is the same on both sides.

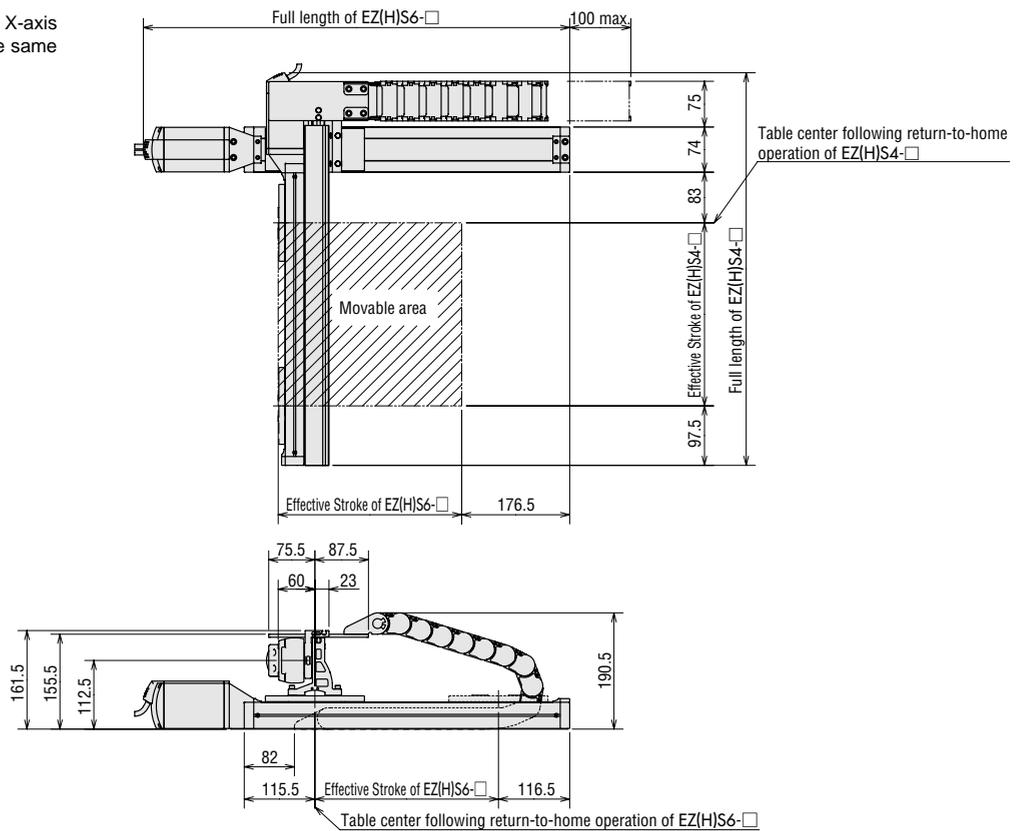

X-Z Configuration Pattern 1

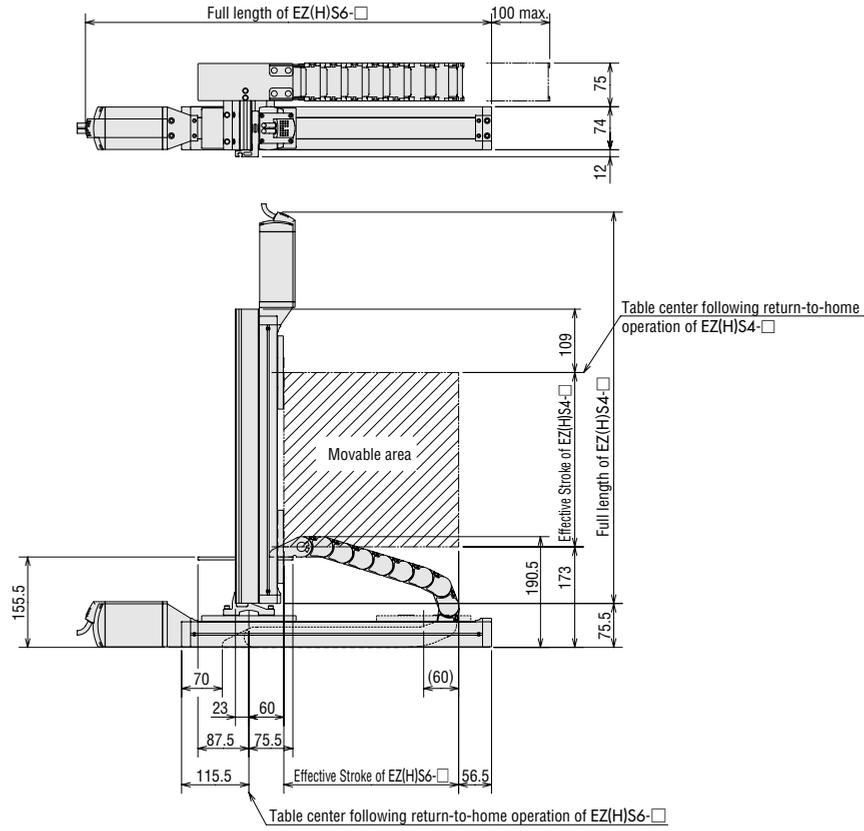

X-Z Configuration Pattern 2

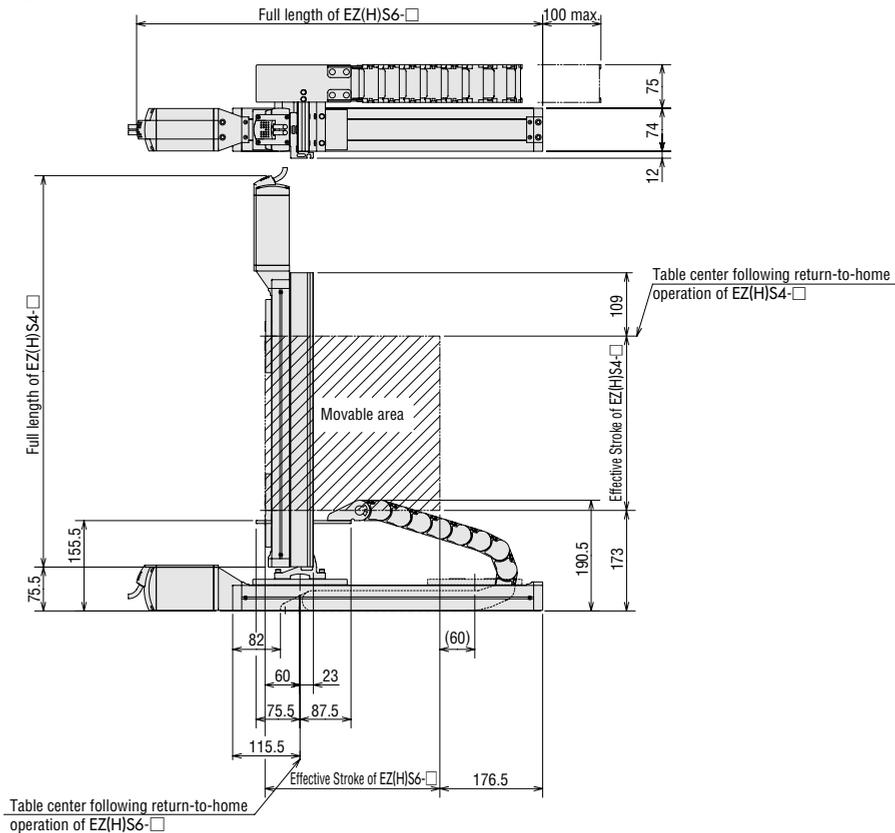

Common Can be used with all series.

EZS EZHS EZC EZHC EZHP Used only with the specified series.

■ Cable Holder

EZS EZHS

This low-noise cable holder protects and guides cables in multi-axis configurations. It can be easily installed on a dual axis mounting bracket using the supplied brackets.

Stroke	Model
100mm	PACH65-13
150mm	PACH65-14
200mm	PACH65-15
250mm	PACH65-17
300mm	PACH65-18
400mm	PACH65-21
500mm	PACH65-24

● Specifications

Model	PACH65-□						
	13	14	15	17	18	21	24
Minimum Bending Radius	mm 50						
Maximum Cable Hose Diameter	mm 20						
Maximum Cable Hose Mass	kg/m 6.5						
Mass*	0.70	0.74	0.77	0.83	0.86	0.96	1.06
Ambient Temperature Range	-10°C ~ +80°C						
Ambient Environment	Avoid use in an acid or alkaline ambience or in hot water.						

*The figures include the weight of brackets used for installation on the dual axis mounting bracket.

● Dimensions unit: mm

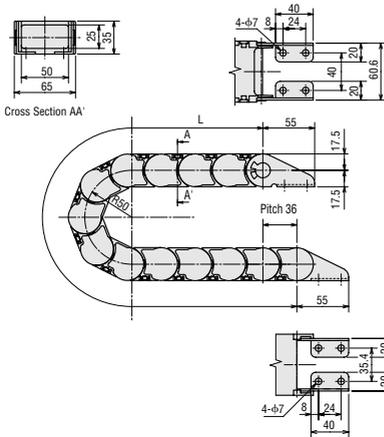

Model	L
PACH65-13	468
PACH65-14	504
PACH65-15	540
PACH65-17	612
PACH65-18	648
PACH65-21	756
PACH65-24	864

■ Cylinder Flange

EZC EZHC EZHP

This special mounting bracket is used to install the cylinder from the body side. The flange comes with the mounting screws for affixing the cylinder to the flange.

(The mounting screws must be provided for affixing the flange to the equipment.)

Model	Applicable Products
PAEZ4-F	EZC4, EZHC4, EZHP4
PAEZ6-F	EZC6, EZHC6, EZHP6

● Dimensions unit: mm

PAEZ4-F

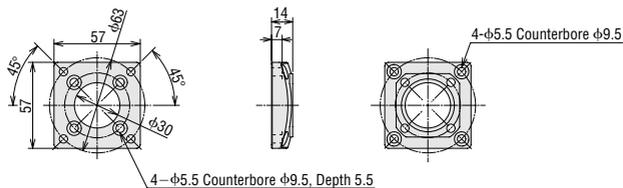

PAEZ6-F

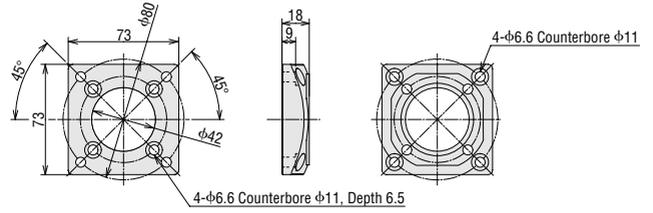

■ DIN Rail Mounting Plate PADPO1

EZS EZC

This plate is used to install the **EZ limo** controller to a DIN rail. The plate comes with the mounting screws.

● Dimensions unit: mm

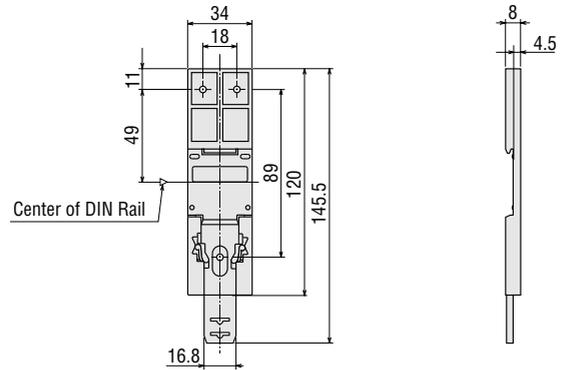

The following spare parts are also available:

● Battery

Model	Applicable Products
PAEZ-BT	EZS · EZC Series
PAEZ-BT2	EZHS · EZHC · EZHP Series

*The spare battery does not come with a battery holder.

- The absolute type of the EZ limo products requires a Nickel Cadmium (Ni-Cd) battery. The Ni-Cd battery must be recycled or disposed of properly in compliance with local, state, and federal regulations.
- For more information regarding recycling of the Ni-Cd battery, contact RBRC, toll free at 1-800-822-8837, or visit <http://www.rbrc.org/>.
- The battery labels complies with "Mercury-Containing and Rechargeable Battery Management Act".
- When handling outside of USA, please consult with your local environmental agency.



Oriental Motor offers a full line of linear-motion products, including the **DRL** series and **LH** series.

We can help you design a more convenient and user-friendly operating environment that meets your various requirements. Please consult us for further details.

Compact Linear Actuators **DRL Series**

The **DRL** Series of compact linear motion actuators use a new 5-phase stepping motor which incorporates a ball screw. These are combined with 5-phase 24 VDC microstepping drivers with photocoupler inputs for extremely precise positioning.

● Compact Design

The compact design of the **DRL** actuator allows for the elimination of extra parts such as couplings, belts and pulleys.

The **DRL** actuator is a self-contained package consisting of a stepping motor with a hollow shaft rotor connected to a ball screw nut. Rotation of the nut initiates movement of the actual ball screw.



To enable linear motion of the screw on an actuator without a guide, provide an external anti-rotation mechanism.

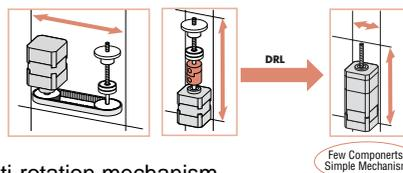

■ Product Line



● Microstepping Drivers

The driver features a microstepping mechanism that electronically divides the basic step angle of the motor, thus enabling high resolution and low-vibration operation at low speeds.

● Reliable Design and Structure

The drive mechanism employs a 5-phase stepping motor with ball screw. The hollow rotor shaft incorporates large bore bearings for the direct handling of thrust loads. Minimizing the number of parts involved in linear conversion results in higher reliability.



Rolled Ball Screw Repetitive Positioning Accuracy ±0.00079 inch (±0.02 mm)	DRL28PA1-03D	DRL42PA2-04D	DRL60PA4-05D	DRL28PA1G-03D	DRL42PA2G-04D	DRL60PA4G-05D
Ground Ball Screw Repetitive Positioning Accuracy ±0.00039 inch (±0.01 mm)	DRL28PB1-03D	DRL42PB2-04D	—	DRL28PB1G-03D	DRL42PB2G-04D	—
Motor Frame Size	28 mm sq.	42 mm sq.	60 mm sq.	28 mm sq.	42 mm sq.	60 mm sq.
Maximum Thrust Force	30 N	100 N	300 N	30 N	100 N	300 N
Type	Standard Type			Guide Type		

Linear Heads LH Series

The **LH** Series of linear heads with a rack-and-pinion mechanism are coupled with standard AC compact motors. They easily produce linear motion for applications pressing and reversing.

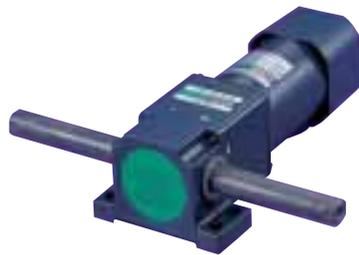

B Type
Reversible Motors (horizontal)
(The motor shown in the photograph is sold separately.)



F Type
Electromagnetic
Brake Motors
(vertical)

● Wide Variety

A wide variety of linear heads are available, depending on basic speed, length of rack, maximum transportable mass, direction of rack movement in respect to the mounting face etc.

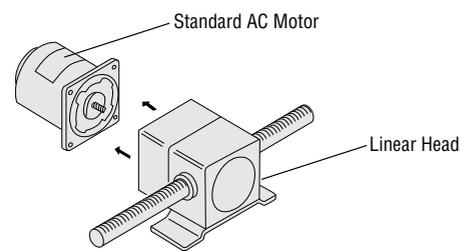

■ Types of Linear Heads

Linear Head Type	Basic Speed (mm/s) ^{*2}				Max. Transportable Mass ^{*3} kg	Rack Stroke (mm)						
	6	12	24	54		100	200	300	400	500	600	700
0L	●	●	●	—	10	●	●	—	—	—	—	—
2L^{*1}	—	●	●	●	20	●	●	●	●	●	—	—
4L	—	●	●	●	70	●	●	●	●	●	●	●
5L-U	—	●	●	●	140	●	●	●	●	●	●	●

*1 The basic speed of **2L** type is 12 mm/s, 30 mm/s, 60 mm/s.

*2 Basic speed is based on the synchronous speed (1800 r/min at 60Hz). The actual speed varies with the load or power supply frequency.

*3 The maximum transportable mass is determined by the strength of the linear head. Just as when connecting a gearhead to a motor, increasing the gear ratio (reducing the speed) generates greater transportable mass, but the motor should always be operated below the maximum permissible transportable mass. The maximum transportable mass is the value when operating the rack in a horizontal direction. When operating in a vertical direction, subtract the mass of the rack from the value. The maximum transportable mass is the value when combined with a reversible motor. The value varies with basic speed.

This product is manufactured at a plant certified with the international standards **ISO 9001** (for quality assurance) and **ISO 14001** (for systems of environmental management).

Specifications are subject to change without notice.
This catalog was published in September, 2006.

ORIENTAL MOTOR U.S.A. CORP.

Western Sales and Customer Service Center

Tel: (310) 784-8200 Fax: (310) 325-1076

Dallas

Tel: (214) 432-3386

Denver

Tel: (303) 202-5111

Los Angeles

Tel: (310) 784-8200

San Jose

Tel: (408) 392-9735

Midwest Sales and Customer Service Center

Tel: (847) 285-5100 Fax: (847) 843-4121

Chicago

Tel: (847) 285-5100

Toronto

Tel: (905) 502-5333

Eastern Sales and Customer Service Center

Tel: (781) 848-2426 Fax: (781) 848-2617

Atlanta

Tel: (770) 716-2800

Boston

Tel: (781) 848-2426

New York

Tel: (973) 359-1100

Technical Support

Tel: (800) 468-3982 / 7:30 a.m. to 5:00 p.m., P.S.T. (M-F)

E-mail: techsupport@orientalmotor.com

**Obtain Specifications, Online Training
and Purchase Products at:
www.orientalmotor.com**