

Cables

Notes on Use of a Flexible Cable

① Do not allow the cable to bend at the cable connector.

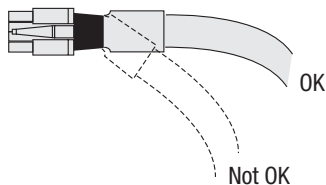

② For the bending radius, use at six times or more of the cable diameter.

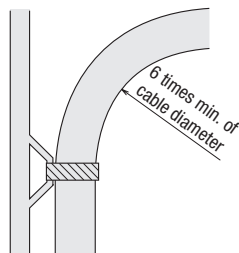

③ Connection cables are not flexible. If regularly bending of the cable is required, use the flexible cable only (sold separately).

Flexible Connection Cable

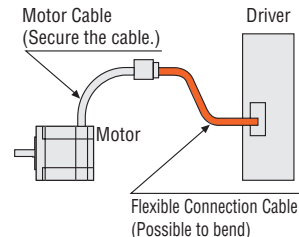

Flexible Extension Cable

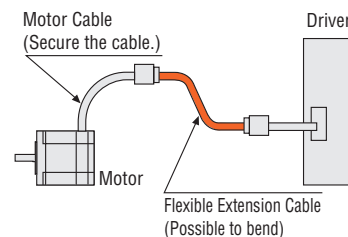

Cables for AR Series AC Input Type

The **AR** Series comes with a 3 m (9.8 ft.) cable for connection between the motor and driver.

When it is necessary to have a connection of a different length between motor and driver, a motor cable or extension cable must be used. The cable for electromagnetic brake motor comes as a set of motor and electromagnetic brake cable.

Use a flexible motor cable if the cable will be flexed repeatedly.

System Configuration of Cables

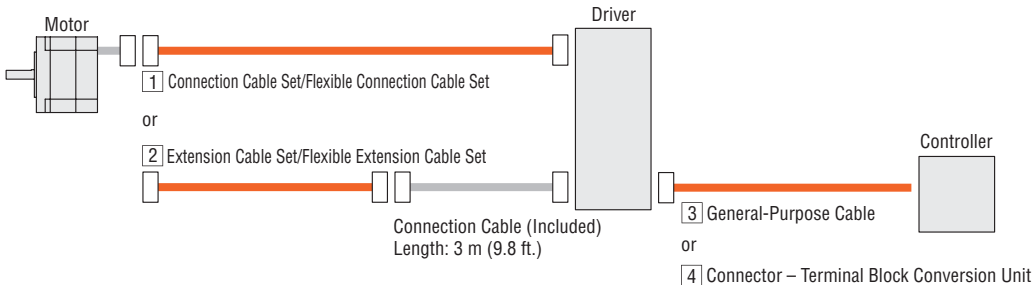

2 Extension Cable Set (RoHS)

Flexible Extension Cable Set (RoHS)

● Product Line

- ◇ Extension Cable Set
- For Standard Motors



Cable for Motor

Model	Length L m (ft.)
CC010VAFT	1 (3.3)
CC020VAFT	2 (6.6)
CC030VAFT	3 (9.8)
CC050VAFT	5 (16.4)
CC070VAFT	7 (23.0)
CC100VAFT	10 (32.8)
CC150VAFT	15 (49.2)
CC200VAFT	20 (65.6)

- ◇ Flexible Extension Cable Set
- For Standard Motors



Cable for Motor

Model	Length L m (ft.)
CC010VART	1 (3.3)
CC020VART	2 (6.6)
CC030VART	3 (9.8)
CC050VART	5 (16.4)
CC070VART	7 (23.0)
CC100VART	10 (32.8)
CC150VART	15 (49.2)
CC200VART	20 (65.6)

● Dimensions Unit = mm (in.)

- ◇ Cable for Motor

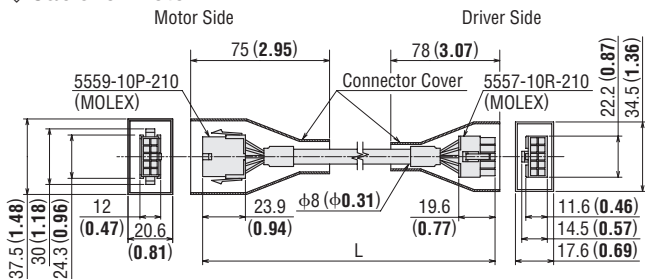

- For Electromagnetic Brake Motor



Cable for Motor



Cable for Electromagnetic Brake

Model	Length L m (ft.)
CC010VAFBT	1 (3.3)
CC020VAFBT	2 (6.6)
CC030VAFBT	3 (9.8)
CC050VAFBT	5 (16.4)
CC070VAFBT	7 (23.0)
CC100VAFBT	10 (32.8)
CC150VAFBT	15 (49.2)
CC200VAFBT	20 (65.6)

- For Electromagnetic Brake Motor



Cable for Motor



Cable for Electromagnetic Brake

Model	Length L m (ft.)
CC010VARBT	1 (3.3)
CC020VARBT	2 (6.6)
CC030VARBT	3 (9.8)
CC050VARBT	5 (16.4)
CC070VARBT	7 (23.0)
CC100VARBT	10 (32.8)
CC150VARBT	15 (49.2)
CC200VARBT	20 (65.6)

- ◇ Cable for Electromagnetic Brake

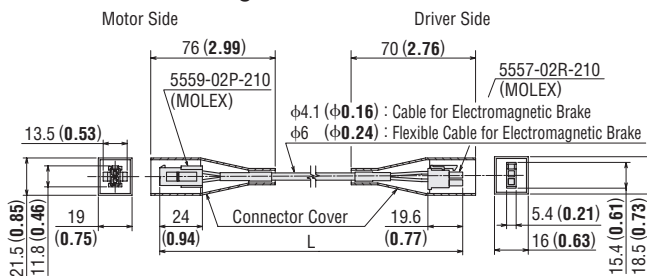

Notes

- Keep the total cable length below 30 m (98.4 ft.) when connecting a cable included in the AR Series and an extension cable.
- Notes on Use of a Flexible Cable → Page A-394

3 General-Purpose Cable (RoHS)



This is a shielded cable equipped with a half-pitch connector at one end of the cable that snaps onto the driver.

The other end is laminated lead wires aligned in order at a pitch of 1.27 mm (0.05 in.), which is convenient for insulation displacement connectors.

Notes

- Note that as the length of the pulse signal line between the driver and controller increases, the maximum transmission frequency decreases.
- Install a connector that matches the controller you are using to the other end of the cable.

Product Line

Model	Applicable Connector	Length L m (ft.)
CC36D1-1	CN5 (36 pins)	1 (3.3)
CC36D2-1		2 (6.6)

Dimensions Unit = mm (in.)

Conductor: AWG28

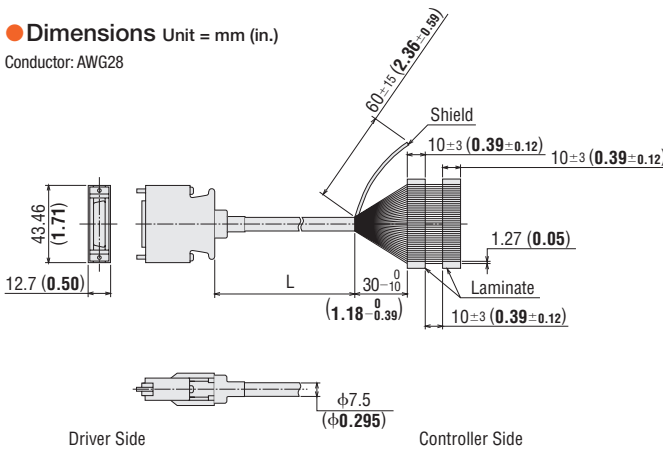

4 Connector – Terminal Block Conversion Unit (RoHS)



CC36T1

A terminal block conversion unit connects a driver to a host controller.

- With a signal name plate for easy, one-glance identification of driver signal names
- DIN-rail mountable
- Application Crimp Terminal: Fork Terminal
- Cable length: 1 m (3.3 ft.)

Product Line

Model	Applicable Connector	Length m (ft.)
CC36T1	CN5 (36 pins)	1 (3.3)

Dimensions Unit = mm (in.)

DXF B438

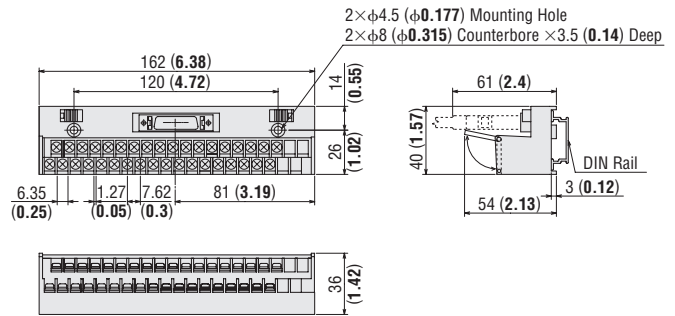

Terminal Block Pin Configuration

19	20	21	22	23	24	25	26	27	28	29	30	31	32	33	34	35	36
1	2	3	4	5	6	7	8	9	10	11	12	13	14	15	16	17	18

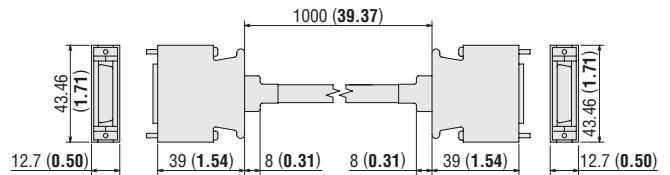

- Recommended Crimp Terminals
- Terminal screw size: M3
- Tightening torque: 1.2 N·m (170 oz-in)
- Applicable minimum lead wire: AWG22

Note

- Round terminals cannot be used.

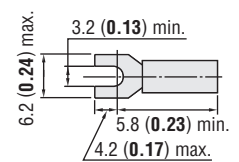

4 General-Purpose Cable (RoHS)



This shielded cable has a half pitch connector at one end for connecting to the **RK** Series driver. The other end is laminated lead wires aligned in order at a pitch of 1.27 mm (0.05 in.), which is convenient for insulation displacement connectors.

Notes

- Note that as the length of the pulse signal line increases, the maximum transmission frequency decreases. Technical reference → Page G-44
- Install a connector that matches the controller you are using to the other end of the cable.

Product Line

Model	Applicable Connector	Length L m (ft.)
CC20D1-1	CN1 (20 pins)	1 (3.3)
CC20D2-1		2 (6.6)

Dimensions Unit = mm (in.)

Conductor: AWG28

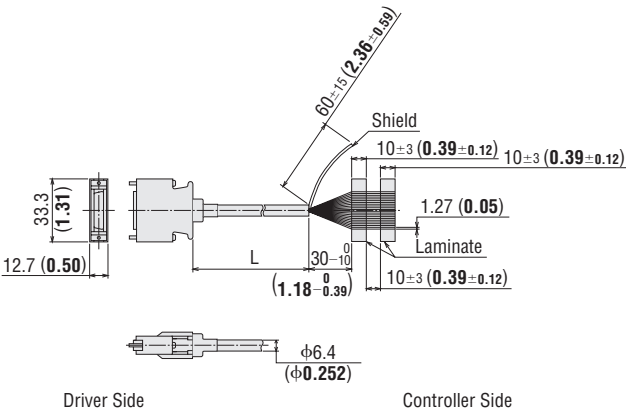

5 Connector – Terminal Block Conversion Unit (RoHS)

This is a conversion unit that connects a driver to a host controller using a terminal block.



CC20T1

- Comes with a signal name plate for easy, one-glance identification of driver signal names.
- DIN rail mountable
- Application Crimp Terminal: Fork Terminal
- Cable length: 1 m (3.3 ft.)

Product Line

Model	Applicable Connector	Length m (ft.)
CC20T1	CN1 (20 pins)	1 (3.3)

Dimensions Unit = mm (in.)

DXF B437

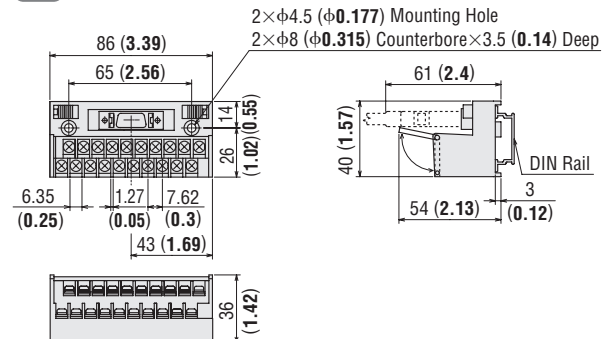

Terminal Block Pin Configuration

1	2	3	4	5	6	7	8	9	10
11	12	13	14	15	16	17	18	19	20

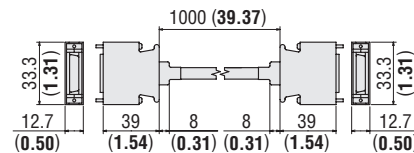

- Recommended Crimp Terminals
- Terminal screw size: M3
- Tightening torque: 1.2 N·m (170 oz-in)
- Applicable minimum lead wire: AWG22

Note

- Round terminals are not available.

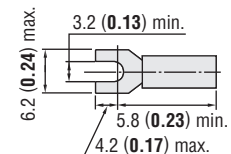

6 Encoder Cable (RoHS)



This encoder cable is available for use with the appropriate motors with encoders. [An encoder cable of 0.6 m (2 ft.) is included with the motor with encoder and driver packages.]

Product Line

Model	Applicable Connector	Length m (ft.)	AWG
LCR05060A	Motor with Encoder	0.6 (2)	24

Introduction
AC Input Motor & Driver
0.36° / Geared
0.72° / Geared
0.9°/1.8°
0.36° / Geared
0.36° / Geared
0.36° / Geared
0.9°/1.8° / Geared
0.9°/1.8° / Geared
1.8° / Geared
0.36°
0.72°
0.9°
1.8°
1.8°
Geared
Controllers
SCX10
/EMP400
/SG8030J
Accessories

Cables for AR Series DC Input Type

The **AR** Series comes with a 3 m (9.8 ft.) cable for connection between the motor and driver.

When it is necessary to have a connection of a different length between motor and driver, a motor cable or extension cable must be used.

The cable for the electromagnetic brake motor comes as a set of the motor and electromagnetic brake cable.

Use a flexible motor cable if the cable will be flexed repeatedly.

System Configuration of Cables

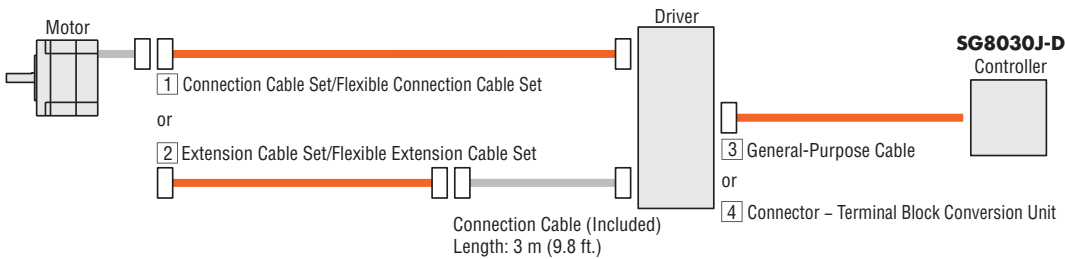

1 Connection Cable Set (RoHS) Flexible Connection Cable Set (RoHS)

Product Line

◇ Connection Cable Set (For **AR24, AR26**)

• For Standard Motor



Cable for Motor

Connection Cable Set

Model	Length L m (ft.)
CC010VA2F2	1 (3.3)
CC020VA2F2	2 (6.6)
CC030VA2F2	3 (9.8)
CC050VA2F2	5 (16.4)
CC070VA2F2	7 (23.0)
CC100VA2F2	10 (32.8)
CC150VA2F2	15 (49.2)
CC200VA2F2	20 (65.6)
CC300VA2F2	30 (98.4)

Flexible Connection Cable Set

Model	Length L m (ft.)
CC010VA2R2	1 (3.3)
CC020VA2R2	2 (6.6)
CC030VA2R2	3 (9.8)
CC050VA2R2	5 (16.4)
CC070VA2R2	7 (23.0)
CC100VA2R2	10 (32.8)
CC150VA2R2	15 (49.2)
CC200VA2R2	20 (65.6)
CC300VA2R2	30 (98.4)

◇ Connection Cable Set (For **AR46, AR66, AR69, AR98, AR911**)

• For Standard Motor



Cable for Motor

Connection Cable Set

Model	Length L m (ft.)
CC010VAF2	1 (3.3)
CC020VAF2	2 (6.6)
CC030VAF2	3 (9.8)
CC050VAF2	5 (16.4)
CC070VAF2	7 (23.0)
CC100VAF2	10 (32.8)
CC150VAF2	15 (49.2)
CC200VAF2	20 (65.6)
CC300VAF2	30 (98.4)

Flexible Connection Cable Set

Model	Length L m (ft.)
CC010VAR2	1 (3.3)
CC020VAR2	2 (6.6)
CC030VAR2	3 (9.8)
CC050VAR2	5 (16.4)
CC070VAR2	7 (23.0)
CC100VAR2	10 (32.8)
CC150VAR2	15 (49.2)
CC200VAR2	20 (65.6)
CC300VAR2	30 (98.4)

• For Electromagnetic Brake Motor



Cable for Motor



Cable for Electromagnetic Brake

Connection Cable Set

Model	Length L m (ft.)
CC010VAFB2	1 (3.3)
CC020VAFB2	2 (6.6)
CC030VAFB2	3 (9.8)
CC050VAFB2	5 (16.4)
CC070VAFB2	7 (23.0)
CC100VAFB2	10 (32.8)
CC150VAFB2	15 (49.2)
CC200VAFB2	20 (65.6)
CC300VAFB2	30 (98.4)

Flexible Connection Cable Set

Model	Length L m (ft.)
CC010VARB2	1 (3.3)
CC020VARB2	2 (6.6)
CC030VARB2	3 (9.8)
CC050VARB2	5 (16.4)
CC070VARB2	7 (23.0)
CC100VARB2	10 (32.8)
CC150VARB2	15 (49.2)
CC200VARB2	20 (65.6)
CC300VARB2	30 (98.4)

● Dimensions Unit = mm (in.)

◇ Cable for Motor (For **AR24, AR26**)

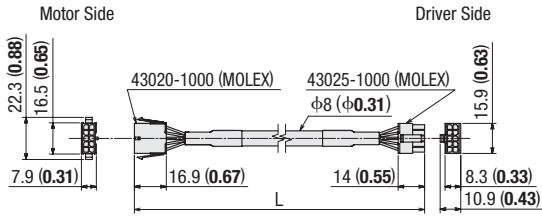

◇ Cable for Motor (For **AR46, AR66, AR69, AR98, AR911**)

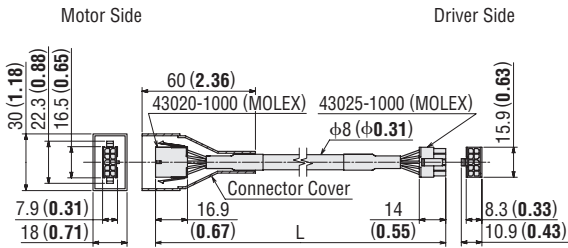

◇ Cable for Electromagnetic Brake (For **AR46, AR66, AR69, AR98, AR911**)

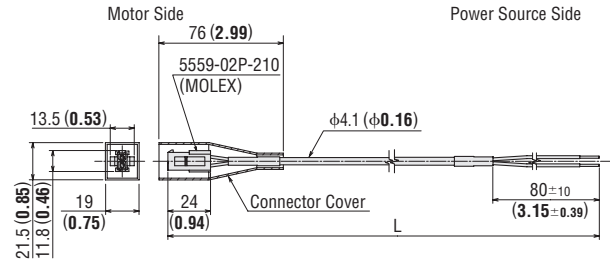

2 Extension Cable Set (RoHS) Flexible Extension Cable Set (RoHS)

● Product Line

◇ Extension Cable Set (For **AR24, AR26**)

- For Standard Motor



Cable for Motor

Extension Cable Set

Model	Length L m (ft.)
CC010VA2F2	1 (3.3)
CC020VA2F2	2 (6.6)
CC030VA2F2	3 (9.8)
CC050VA2F2	5 (16.4)
CC070VA2F2	7 (23.0)
CC100VA2F2	10 (32.8)
CC150VA2F2	15 (49.2)
CC200VA2F2	20 (65.6)

Flexible Extension Cable Set

Model	Length L m (ft.)
CC010VA2R2	1 (3.3)
CC020VA2R2	2 (6.6)
CC030VA2R2	3 (9.8)
CC050VA2R2	5 (16.4)
CC070VA2R2	7 (23.0)
CC100VA2R2	10 (32.8)
CC150VA2R2	15 (49.2)
CC200VA2R2	20 (65.6)

◇ Extension Cable Set (For **AR46, AR66, AR69, AR98, AR911**)

- For Standard Motor



Cable for Motor

Extension Cable Set

Model	Length L m (ft.)
CC010VAF2	1 (3.3)
CC020VAF2	2 (6.6)
CC030VAF2	3 (9.8)
CC050VAF2	5 (16.4)
CC070VAF2	7 (23.0)
CC100VAF2	10 (32.8)
CC150VAF2	15 (49.2)
CC200VAF2	20 (65.6)

Flexible Extension Cable Set

Model	Length L m (ft.)
CC010VART2	1 (3.3)
CC020VART2	2 (6.6)
CC030VART2	3 (9.8)
CC050VART2	5 (16.4)
CC070VART2	7 (23.0)
CC100VART2	10 (32.8)
CC150VART2	15 (49.2)
CC200VART2	20 (65.6)

- For Electromagnetic Brake Motor



Cable for Motor



Cable for Electromagnetic Brake

Extension Cable Set

Model	Length L m (ft.)
CC010VAFBT2	1 (3.3)
CC020VAFBT2	2 (6.6)
CC030VAFBT2	3 (9.8)
CC050VAFBT2	5 (16.4)
CC070VAFBT2	7 (23.0)
CC100VAFBT2	10 (32.8)
CC150VAFBT2	15 (49.2)
CC200VAFBT2	20 (65.6)

Flexible Extension Cable Set

Model	Length L m (ft.)
CC010VARBT2	1 (3.3)
CC020VARBT2	2 (6.6)
CC030VARBT2	3 (9.8)
CC050VARBT2	5 (16.4)
CC070VARBT2	7 (23.0)
CC100VARBT2	10 (32.8)
CC150VARBT2	15 (49.2)
CC200VARBT2	20 (65.6)

● **Dimensions** Unit = mm (in.)

◇ **Cable for Motor**
(For **AR24, AR26**)

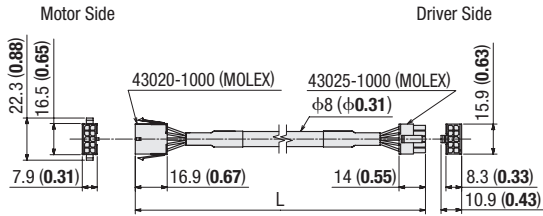

◇ **Cable for Motor**
(For **AR46, AR66, AR69, AR98, AR911**)

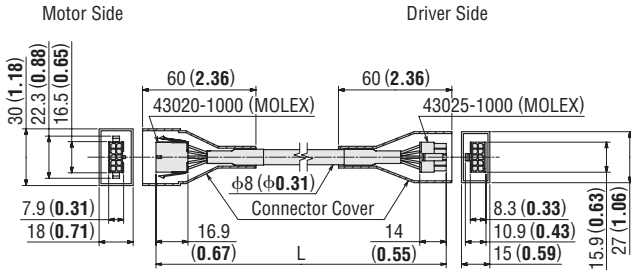

◇ **Cable for Electromagnetic Brake**
(For **AR46, AR66, AR69, AR98, AR911**)

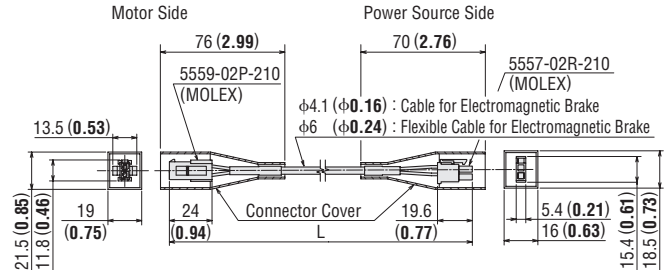

Notes

- Keep the total cable length below 30 m (98.4 ft.) when connecting a cable included in the **AR** Series and an extension cable or a flexible extension cable.
- Notes on Use of a Flexible Cable → Page A-394

3 General-Purpose Cable (RoHS)



This is a shielded cable equipped with a half-pitch connector at one end of the cable that snaps onto the driver. The other end is laminated lead wires aligned in order at a pitch of 1.27 mm (0.05 in.), which is convenient for insulation displacement connectors.

Notes

- Note that as the length of the pulse signal line between the driver and controller increases, the maximum transmission frequency decreases.
- Install a connector that matches the controller you are using to the other end of the cable.

● **Product Line**

Model	Applicable Connector	Length L m (ft.)
CC36D1-1	CN5 (36 pins)	1 (3.3)
CC36D2-1		2 (6.6)

● **Dimensions** Unit = mm (in.)

Conductor: AWG28

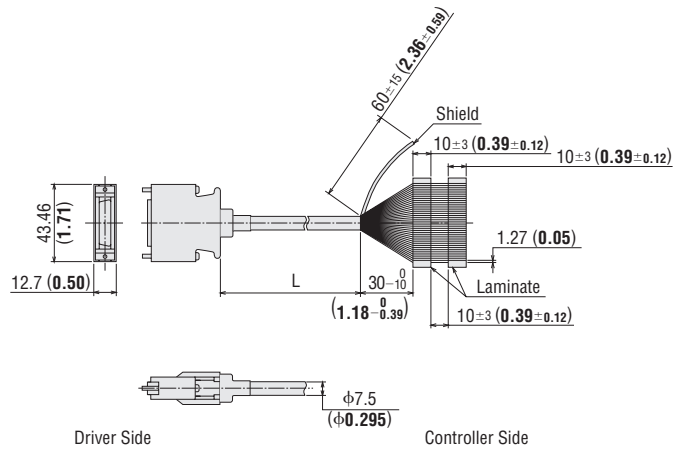

4 Connector – Terminal Block Conversion Unit (RoHS)



CC36T1

This is a conversion unit that connects a driver to a host controller using a terminal block.

- Comes with a signal name plate for easy, one-glance identification of driver signal names
- DIN-rail mountable
- Application Crimp Terminal: Fork Terminal
- Cable length: 1 m (3.3 ft.)

Product Line

Model	Applicable Connector	Length m (ft.)
CC36T1	CN5 (36 pins)	1 (3.3)

Dimensions Unit = mm (in.)

DXF B438

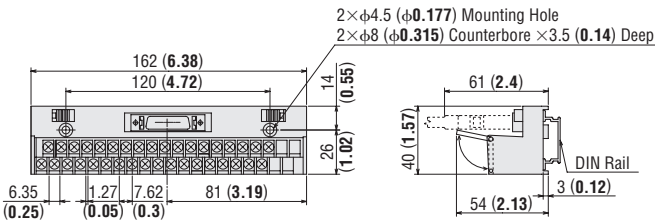

Terminal Block Pin Configuration

19	20	21	22	23	24	25	26	27	28	29	30	31	32	33	34	35	36
1	2	3	4	5	6	7	8	9	10	11	12	13	14	15	16	17	18

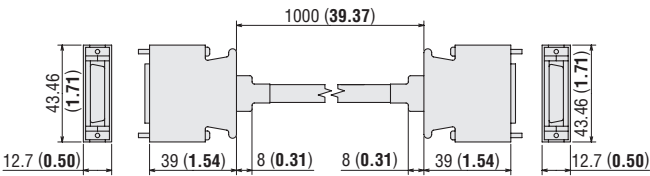

- Recommended Crimp Terminals
- Terminal screw size: M3
- Tightening torque: 1.2 N·m (170 oz-in)
- Applicable minimum lead wire: AWG22

Note

- Round terminals cannot be used.

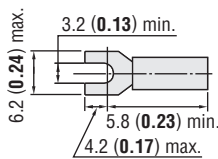

Introduction	
AC Input Motor & Driver	0.36° / Geared / Gearing / ASX
UMK	0.9°/1.8°
DC Input Motor & Driver	0.36° / Geared / Gearing / ASX
CRK	0.36°/0.72° / Geared / Gearing
CMK	0.9°/1.8° / Geared / Gearing
RBK	1.8° / Geared / Gearing
PK	0.36°
PK	0.72°
PK	0.9°
PK/PV	1.8°
Geared / Gearing / PK	
Controllers	SCX10 / EMP400 / SG8030J
Accessories	

Cables for CRK Series

System Configuration of Cables

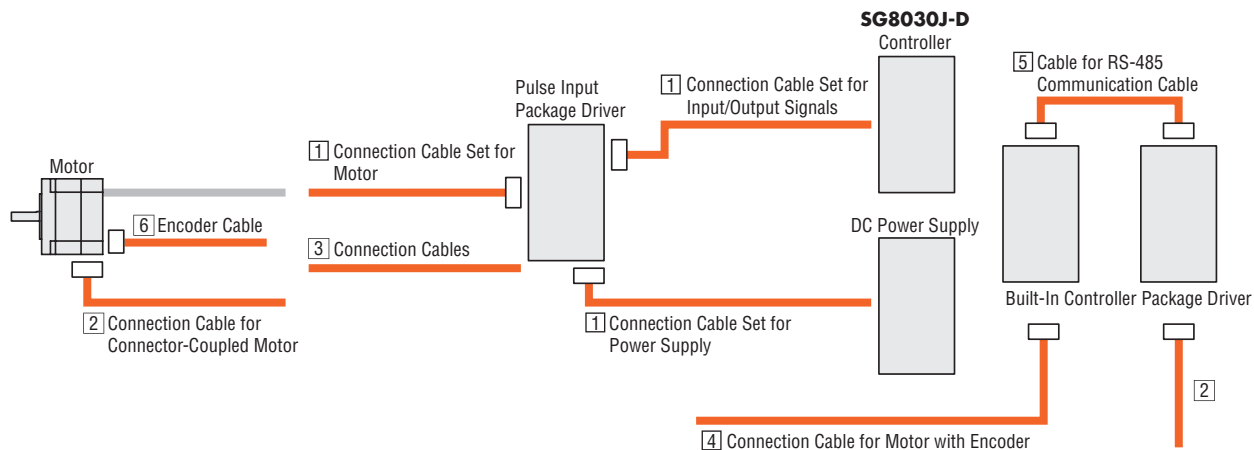

1 Connection Cable Set (RoHS)



Lead wires with a connector are available as an accessory for DC input drivers. These lead wires allow for easy connection of the motor, power supply and input/output signals without crimping. The connection cable set includes three connection cables (for motor, power supply and input/output signals).

Product Line

Model	Applicable Driver	Length m (ft.)	AWG
LCS04SD5	CRD5103P CRD5107P CRD5107HP CRD5114P	0.6 (2)	22

2 Connection Cables (RoHS)



This lead wire type connection cable with a conveniently crimped connector is for connecting connector-coupled motors, and for connecting motors and drivers.

Product Line

Model	Applicable Motor	Length m (ft.)	AWG
LC5N06A	PK513 PK523	0.6 (2)	24
LC5N10A	PK524 PK525	1 (3.3)	
LC5N06B	PK544	0.6 (2)	22
LC5N10B	PK546	1 (3.3)	
LC5N06C	PK564 PK566	0.6 (2)	
LC5N10C	PK569	1 (3.3)	

● The applicable motor products are listed such that the model can be determined.

3 Connection Cables RoHS



These connection cables are used between **CRK** Series motors and dedicated drivers. Keep the total cable length below 10 m (32.8 ft.).

● Product Line

Model	Length m (ft.)	Conductors
CC05PK5	5 (16.4)	5
CC10PK5	10 (32.8)	

- Conductor configuration: 5
- Conductor size: AWG22
- Finished outer diameter: ϕ 7.2 mm (ϕ 0.28 in.)
- Cable rating: 105 °C (221 °F)
- Outer casing: Oil-resistant, heat-resistant, non-migrating vinyl

4 Connection Cable for Motor with Encoder RoHS



These lead wires with connector assemblies are available for use with the appropriate connector-coupled motors. [A connection cable of 0.6 m (2 ft.) is included with the connector-coupled motor and driver packages.]

● Product Line

Model	Application	Length m (ft.)	AWG
LC09A-006	For Encoder Connection	0.6 (2)	22

5 Cable for RS-485 Communication Cable RoHS



These cables are used to link drivers when a built-in controller type is being operated in a multi-drop manner.

● Product Line

Model
CC001-RS4

● Dimensions Unit = mm (in.)

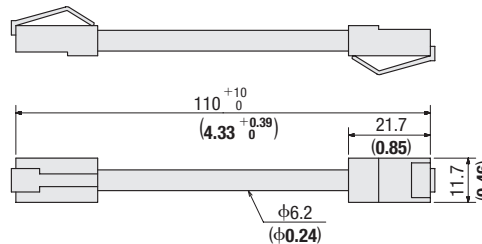

6 Encoder Cables RoHS



LCR05060A



LCR09060A

These encoder cables are available for use with the appropriate motors with encoders. [An encoder cable of 0.6 m (2 ft.) is included with the motor with encoder and driver packages.]

● Product Line

Model	Applicable Product	Length m (ft.)	AWG
LCR05060A	Pulse Input Package for Motor with Encoder	0.6 (2)	24
LCR09060A	Built-In Controller for Motor with Encoder		22

Cables for CMK Series

System Configuration of Cables

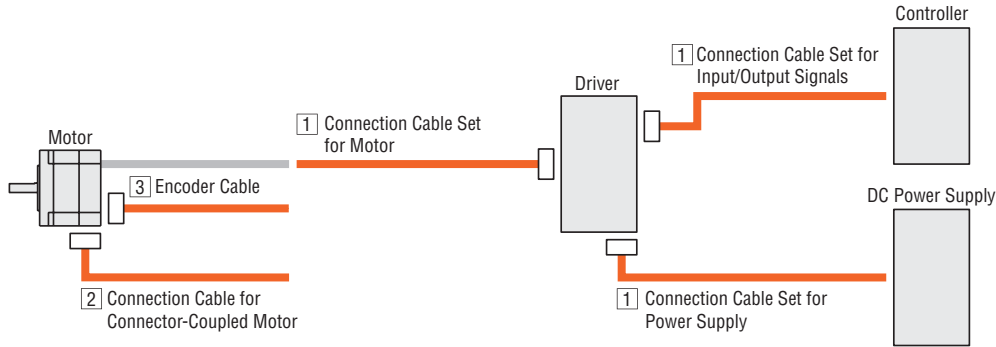

1 Connection Cable Set (RoHS)



As an accessory for DC input drivers, lead wires with a connector are available. These lead wires allow for easy connection of the motor, power supply and input/output signals without crimping. The connection cable set includes three connection cables (for motor, power supply and input/output signals).

Product Line

Model	Applicable Driver	Length m (ft.)	AWG
LC501CMK2	CMD21 09P	0.6 (2)	22
	CMD21 12P		
	CMD21 20P		

2 Connection Cables (RoHS)

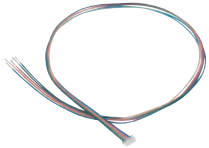

These lead wires with connector assemblies are available for use with the appropriate connector-coupled motors. [A connection cable of 0.6 m (2 ft.) is included with the connector-coupled motor and driver packages.]

3 Encoder Cables (RoHS)



These encoder cables are available for use with the appropriate motors with encoders. [An encoder cable of 0.6 m (2 ft.) is included with the motor with encoder and driver packages.]

Product Line

Model	Applicable Motor	Length m (ft.)	AWG
LC2U06A	PK223P PK224P PK225P	0.6 (2)	24
LC2U10A		1 (3.3)	
LC2U06B	PK233P PK235P PK244P PK246P	0.6 (2)	
LC2U10B		1 (3.3)	
LC2U06C	PK264P PK266P PK268P	0.6 (2)	22
LC2U10C		1 (3.3)	

● The applicable motor products are listed such that the model can be determined.

Product Line

Model	Applicable Product	Length m (ft.)	AWG
LCR04060B	CMK22 □ Motor with Encoder	0.6 (2)	24
LCR04060A	CMK23 □ / CMK24 □ / CMK26 □ Motor with 2-Channel Encoder		
LCR05060A	CMK23 □ / CMK24 □ / CMK26 □ Motor with 3-Channel Encoder		

Cables for RBK Series

System Configuration of Cables

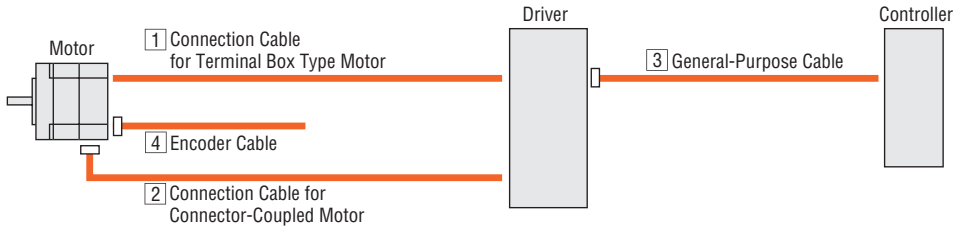

1 Connection Cable for Terminal Box Type Motor (RoHS)



A cable for connection between the terminal box type motor and driver (with protective earth wire)

Product Line

Model	Length m (ft.)	Conductors
CC03PKT	3 (9.8)	6

- Conductor configuration: 6
- Conductor size: Motor wire AWG18, protective earth wire AWG14
- Finished outer diameter: $\phi 12$ mm ($\phi 0.47$ in.)
- Cable rating: 105°C (221°F) 600 V
- Outer casing: Heat-resistant, oil-resistant vinyl chloride resin
- Applicable standards: UL 758 (AWM) VW-1, UL Style 2586

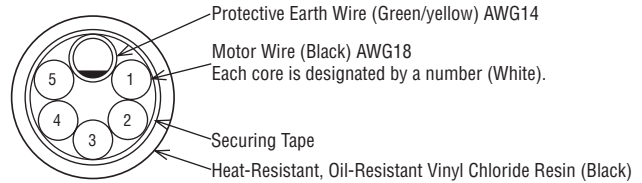

2 Connection Cables (RoHS)

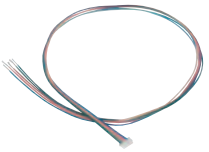

These lead wires with connector assemblies are available for use with the appropriate connector-coupled motors. [A motor lead wire/connector assembly of 0.6 m (2 ft.) is included with the connector-coupled motor and driver packages.]

Product Line

Model	Applicable Motor	Length m (ft.)	AWG
LC2B06A	PK223P	0.6 (2)	24
	PK224P		
	PK225P		
LC2B06B	PK233P	0.6 (2)	24
	PK235P		
	PK244P		
LC2B06C	PK264P	0.6 (2)	22
	PK266P		
	PK268P		

- The applicable motor products are listed such that the model can be determined.

3 General-Purpose Cables RoHS



These are dedicated 15-conductor cables for connecting the I/O signal connector and programmable controller. They are high-quality, noise-blocking, double-shielded cables.

Model	Length L [m (ft.)]
CC15D1	1 (3.3)
CC15D2	2 (6.6)

● **Dimensions** Unit = mm (in.)

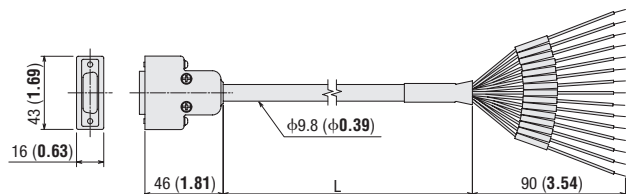

● **Noise-Blocking Property**

The figure below shows the noise effects on a signal line. As you can see, the noise-blocking effect is high with signal lines that have a low level value. Oriental Motor driver cables come with double-shielding that includes aluminum foil-shielding and braided-shielding, which provides excellent noise-blocking characteristics.

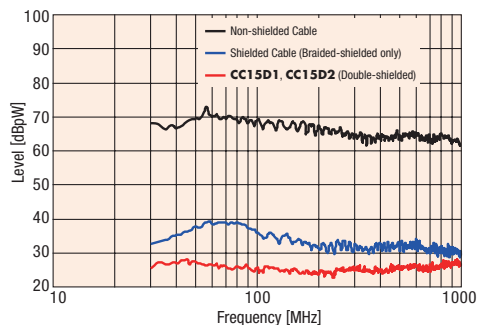

4 Encoder Cables RoHS



These encoder cables are available for use with the appropriate motors with encoders.

[An encoder cable of 0.6 m (2 ft.) is included with the motor with encoder and driver packages.]

● **Product Line**

Model	Applicable Product	Length m (ft.)	AWG
LCR04060B	RBK22 □ Motor with Encoder	0.6 (2)	24
LCR04060A	RBK23 □/ RBK24 □/ RBK26 □ Motor with 2-Channel Encoder		
LCR05060A	RBK23 □/ RBK24 □/ RBK26 □ Motor with 3-Channel Encoder		

Cables for Step Angle 0.9°/1.8° Stepping Motor

System Configuration of Cables

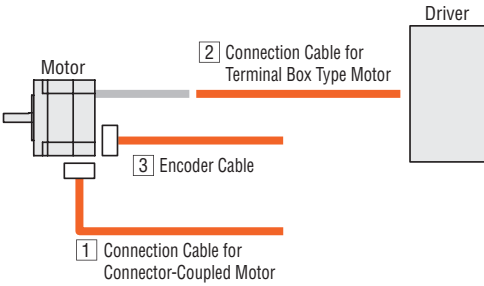

1 Connection Cables (RoHS)

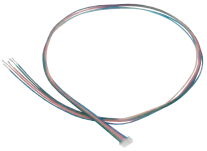

These lead wires with connector assemblies are available for use with the appropriate connector-coupled motors. [A motor lead wire/connector assembly of 0.6 m (2 ft.) is included with the connector-coupled motor and driver packages.]

Product Line

Model	Applicable Product	Length m (ft.)	AWG
LC2U06A	PK223P, PK224P, PK225P	0.6 (2)	24
LC2U10A		1 (3.3)	
LC2U06B	PK233P, PK235P PK244P, PK246P	0.6 (2)	
LC2U10B		1 (3.3)	
LC2U06C	PK264P, PK266P, PK268P	0.6 (2)	22
LC2U10C		1 (3.3)	
LC2B06A	PK223PD, PK224PD, PK225PD	0.6 (2)	24
LC2B06B	PK233PD, PK235PD PK244PD, PK246PD	0.6 (2)	
	PKE243D, PKE244D, PKE245D		
LC2B06C	PK264PD, PK266PD, PK268PD	0.6 (2)	22

● The applicable motor products are listed such that the model can be determined.

3 Encoder Cables (RoHS)



These encoder cables are available for use with the appropriate motors with encoders. [An encoder cable of 0.6 m (2 ft.) is included with the motor with encoder and driver packages.]

2 Connection Cable for Terminal Box Type Motor (RoHS)



A cable for connection between the terminal box type motor and driver (with protective earth wire).

Product Line

Model	Length m (ft.)	Conductors
CC03PKT	3 (9.8)	6

- Conductor configuration: 6
- Conductor size: Motor wire AWG18, protective earth wire AWG14
- Finished outer diameter: $\phi 12$ mm ($\phi 0.47$ in.)
- Cable rating: 105°C (221°F) 600 V
- Outer casing: Heat-resistant, oil-resistant vinyl chloride resin
- Applicable standards: UL 758 (AWM) VW-1, UL Style 2586

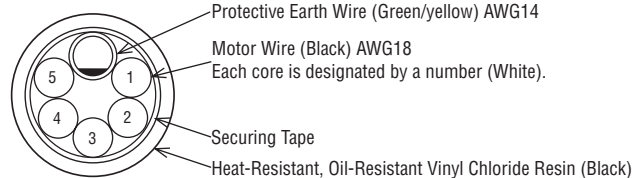

Product Line

Model	Applicable Product	Length m (ft.)	AWG
LCR05060A	PK54□/PK56□/PK59□ with TTL Type Encoder	0.6 (2)	24
	PK23□/PK24□/PK26□ with TTL Type, 3-channel Encoder		
LCR09060A	PK54□/PK56□ with Differential Type Encoder		22
LCR04060B	PK22□		24
LCR04060A	PK23□/PK24□/PK26□ with TTL Type, 2-channel Encoder		

Cables for Step Angle 0.36°/0.72° Stepping Motor

The cable that is used depends on the drivers that are being combined. Refer to the following pages for more information.

If **RK** series drivers are being combined → Page A-398

If **CRK** series drivers are being combined → Page A-404

Flexible Couplings RoHS

MCS Couplings

Features

- No backlash.
- High strength (usable for geared motor) is now available.
- A spider (material: polyurethane) controls the vibration generated by the motor.



Product Number Code

MCS 30 10 12

① ② ③ ④

①	MCS Coupling
②	Outer Diameter of Coupling
③	Inner Diameter d1 (Smaller inner diameter) [F04 represents $\phi 6.35$ mm ($\phi 0.25$ in.)]
④	Inner Diameter d2 (Larger inner diameter) [F04 represents $\phi 6.35$ mm ($\phi 0.25$ in.)]

- For inner diameter d1, the smaller of the motor shaft diameter or the driven shaft diameter is entered.
- For inner diameter d2, the larger of the motor shaft diameter or the driven shaft diameter is entered.

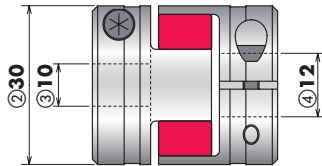

Product Line

Model	Coupling Outer Diameter mm (in.)
MCS14□	$\phi 14$ ($\phi 0.55$)
MCS20□	$\phi 20$ ($\phi 0.79$)
MCS30□	$\phi 30$ ($\phi 1.18$)
MCS40□	$\phi 40$ ($\phi 1.57$)
MCS55□	$\phi 55$ ($\phi 2.17$)
MCS65□	$\phi 65$ ($\phi 2.56$)

- A number indicating the coupling inner diameter is entered where the box □ is located within the product name.

Selecting a Coupling

The following examples explain the procedures in selecting a coupling by driven shaft diameter and motor and driver package name.

Example: Product Name: AR46AC-N10-3 Driven Shaft Diameter: $\phi 12$ mm ($\phi 0.4724$ in.)

1. The coupling type that matches **AR46AC-N10-3** from the coupling selection table is **MCS30**.
2. The inner diameter of the coupling according to the motor shaft will be **10** [$\phi 10$ mm ($\phi 0.3937$ in.)], and will be **12** [$\phi 12$ mm ($\phi 0.4724$ in.)] according to the driven shaft diameter.
3. In the coupling product name, smaller inner diameters come before larger ones, thus the coupling product name will be **MCS301012**.

- When the inner diameter is $\phi 6.35$ mm ($\phi 0.2500$ in.), the number is **F04**. For example, when the coupling type is **MCS30**, the motor shaft diameter is **08** [$\phi 8$ mm ($\phi 0.3150$ in.)], and the driven shaft diameter is **F04** [$\phi 6.35$ mm ($\phi 0.2500$ in.)], the coupling product name will be **MCS30F0408**.

Coupling Selection Table

● Low-Speed Synchronous Motors SMK Series (Geared Motor)

Applicable Product		Coupling Type	Motor Shaft Diameter mm (in.)	Driven Shaft Diameter mm (in.)					
Model	Gear Ratio			04	05	06	F04	08	10
				$\phi 4$ ($\phi 0.1575$)	$\phi 5$ ($\phi 0.1969$)	$\phi 6$ ($\phi 0.2362$)	$\phi 6.35$ ($\phi 0.2500$)	$\phi 8$ ($\phi 0.3150$)	$\phi 10$ ($\phi 0.3937$)
SMK0A-□	3, 3.6, 7.5 9, 15, 18 30, 36, 50	MCS14	05 $\phi 5$ ($\phi 0.1969$)	●	●	●			
	60, 100, 120	MCS20	05 $\phi 5$ ($\phi 0.1969$)		●	●	●	●	●

- Enter the gear ratio in the box (□) within the model name.
- The applicable motor products are listed such that the model can be determined.

● Brushless Motors

Applicable Product	Coupling Type	Motor Shaft Diameter mm (in.)		Driven Shaft Diameter mm (in.)											
				5	6	F04	8	10	12	14	15	16			
				φ5 (φ0.1969)	φ6 (φ0.2362)	φ6.35 (φ0.2500)	φ8 (φ0.3150)	φ10 (φ0.3937)	φ12 (φ0.4724)	φ14 (φ0.5512)	φ15 (φ0.5906)	φ16 (φ0.6299)			
BX230	MCS20	8	φ8 (φ0.3150)	●	●	●	●	●							
BX460	MCS20	10	φ10 (φ0.3937)	●	●	●									
BX5120	MCS30	12	φ12 (φ0.4724)		●				●	●	●	●			
BX6200, BX6400	MCS30	14	φ14 (φ0.5512)		●				●	●	●	●	●	●	●

● The applicable motor products are listed such that the model can be determined.

● AR Series

Applicable Product				Coupling Type	Motor Shaft Diameter mm (in.)	Driven Shaft Diameter mm (in.)														
Type	Motor Frame Size	Model	Gear Ratio			04	05	06	F04	08	10	12	14	15	16	18	20	22	24	25
						φ4 (φ0.1575)	φ5 (φ0.1969)	φ6 (φ0.2362)	φ6.35 (φ0.2500)	φ8 (φ0.3150)	φ10 (φ0.3937)	φ12 (φ0.4724)	φ14 (φ0.5512)	φ15 (φ0.5906)	φ16 (φ0.6299)	φ18 (φ0.7087)	φ20 (φ0.7874)	φ22 (φ0.8661)	φ24 (φ0.9445)	φ25 (φ0.9843)
Step Angle 0.36° Standard Type	28 mm (1.10 in.)	AR24 AR26	-	MCS14 05	φ5 (φ0.1969)	●	●	●												
	42 mm (1.65 in.)	AR46	-	MCS14 06	φ6 (φ0.2362)	●	●	●												
	60 mm (2.36 in.)	AR66 AR69	-	MCS30 10	φ10 (φ0.3937)		●	●	●	●	●	●	●	●						
	85 mm (3.35 in.)	AR98 AR911	-	MCS30 14	φ14 (φ0.5512)		●		●	●	●	●	●	●						
TH Geared Type	28 mm (1.10 in.)	AR24-T□	7.2, 10, 20, 30	MCS14 05	φ5 (φ0.1969)	●	●	●												
	42 mm (1.65 in.)	AR46-T□	3.6, 7.2, 10	MCS20 06	φ6 (φ0.2362)		●	●	●	●	●									
			20, 30	MCS30 06	φ6 (φ0.2362)		●	●	●	●	●	●	●	●						
	60 mm (2.36 in.)	AR66-T□	3.6, 7.2	MCS30 08	φ8 (φ0.3150)		●	●	●	●	●	●	●	●	●					
		10, 20, 30	MCS40 08	φ8 (φ0.3150)			●	●	●	●	●	●	●	●	●					
90 mm (3.54 in.)	AR98-T□	3.6, 7.2, 10, 20, 30	MCS55 12	φ12 (φ0.4724)						●	●	●	●	●	●	●	●	●	●	
PS Geared Type	28 mm (1.10 in.)	AR24-PS□	5, 7.2, 10	MCS20 08	φ8 (φ0.3150)		●	●	●	●	●									
	42 mm (1.65 in.)	AR46-PS□	5, 7.2, 10	MCS30 10	φ10 (φ0.3937)			●	●	●	●	●	●	●						
			25, 36, 50	MCS40 10	φ10 (φ0.3937)				●	●	●	●	●	●	●	●				
	60 mm (2.36 in.)	AR66-PS□	5, 7.2	MCS40 12	φ12 (φ0.4724)				●	●	●	●	●	●	●	●				
		10, 25, 36, 50	MCS55 12	φ12 (φ0.4724)						●	●	●	●	●	●	●	●	●	●	
90 mm (3.54 in.)	AR98-PS□	5, 7.2, 10, 25, 36, 50	MCS65 18	φ18 (φ0.7087)								●	●	●	●	●	●	●	●	
PN Geared Type	28 mm (1.10 in.)	AR24-N□	5, 7.2, 10	MCS20 08	φ8 (φ0.3150)		●	●	●	●										
	42 mm (1.65 in.)	AR46-N□	5, 7.2, 10	MCS30 10	φ10 (φ0.3937)			●	●	●	●	●	●							
			5, 7.2	MCS40 12	φ12 (φ0.4724)				●	●	●	●	●	●	●	●				
	60 mm (2.36 in.)	AR66-N□	10, 25, 36, 50	MCS55 12	φ12 (φ0.4724)					●	●	●	●	●	●	●	●	●	●	
		5, 7.2, 10, 25, 36, 50	MCS65 18	φ18 (φ0.7087)								●	●	●	●	●	●	●	●	
90 mm (3.54 in.)	AR98-N□	5, 7.2, 10, 25, 36, 50	MCS65 18	φ18 (φ0.7087)								●	●	●	●	●	●	●	●	
Harmonic Geared Type	30 mm (1.18 in.)	AR24-H□	50, 100	MCS30 08	φ8 (φ0.3150)		●	●	●	●	●	●	●	●						
	42 mm (1.65 in.)	AR46-H□	50, 100	MCS40 10	φ10 (φ0.3937)			●	●	●	●	●	●	●	●					
	60 mm (2.36 in.)	AR66-H□	50, 100	MCS55 12	φ12 (φ0.4724)					●	●	●	●	●	●	●	●	●	●	
	90 mm (3.54 in.)	AR98-H□	50, 100	MCS65 18	φ18 (φ0.7087)								●	●	●	●	●	●	●	

● A number indicating the gear ratio is entered where the box (□) is located.

● The applicable motor products are listed such that the model can be determined.

Introduction

AR / D_{STEP} / Geared / AS / 0.36° / Geared / 0.72° / Geared / RK

AC Input Motor & Driver

0.9° / 1.8° / UMK

DC Input Motor & Driver

0.36° / Geared / AR / 0.36° / Geared / ASX / 0.36° / Geared / CRK / 0.9° / 1.8° / Geared / CMK / 1.8° / Geared / RBK

Motor Only

0.36° / PK / 0.72° / PK / 0.9° / PK / 1.8° / PK / PV / Geared / PK

Controllers

SCX10 / EMP400 / SG8030J

Accessories

● RK Series, CRK Series, Motor Only PK Series

Applicable Product				Driven Shaft Diameter mm (in.)																		
Type	Motor Frame Size	Model	Gear Ratio	Coupling Type	Motor Shaft Diameter mm (in.)	04	05	06	F04	08	10	12	14	15	16	18	20	22	24	25		
						φ4 (φ0.1575)	φ5 (φ0.1969)	φ6 (φ0.2362)	φ6.35 (φ0.2500)	φ8 (φ0.3150)	φ10 (φ0.3937)	φ12 (φ0.4724)	φ14 (φ0.5512)	φ15 (φ0.5906)	φ16 (φ0.6299)	φ18 (φ0.7087)	φ20 (φ0.7874)	φ22 (φ0.8661)	φ24 (φ0.9445)	φ25 (φ0.9843)		
Step Angle 0.36° High-Torque Type	28 mm (1.10 in.)	CRK523 CRK524 CRK525 PK523 PK524 PK525	-	MCS14	05	φ5 (φ0.1969)	●	●	●													
		CRK544 CRK546 PK544 PK546					●	●	●													
	60 mm (2.36 in.)	CRK564 CRK566 PK564 PK566	-	MCS30	08	φ8 (φ0.3150)		●	●	●	●	●										
		CRK569 PK569					MCS30	10	φ10 (φ0.3937)			●	●	●	●	●						
Step Angle 0.72° Standard Type	20 mm (0.79 in.)	CRK513 PK513	-	MCS14	04	φ4 (φ0.1575)	●	●	●													
	28 mm (1.10 in.)	CRK523 CRK525 PK523 PK525	-	MCS14	05	φ5 (φ0.1969)	●	●	●													
	42 mm (1.65 in.)	RK543 RK544 RK545 CRK543 CRK544 CRK545 CRK546 PK543 PK544 PK545 PK546	-	MCS14	05	φ5 (φ0.1969)	●	●	●													
		RK564 RK564T RK566 RK566T CRK564 CRK566 PK564 PK564T PK566 PK566T RK569 RK569T CRK569 PK569 PK569T	-	MCS20	08	φ8 (φ0.3150)		●	●	●	●	●										
	60 mm (2.36 in.)	RK569 RK569T CRK569 PK569 PK569T	-	MCS30	08	φ8 (φ0.3150)		●	●	●	●	●										
		RK596 RK596T PK596 PK596T	-	MCS30	14	φ14 (φ0.5512)						●	●	●		●						
85 mm (3.35 in.)	RK599 RK599T RK5913 RK5913T PK599 PK599T PK5913 PK5913T	-	MCS55	14	φ14 (φ0.5512)							●	●	●	●							

- Enter the gear ratio in the box (□) within the model name.
- These couplings can also be used with a motor with an encoder.

Applicable Product				Coupling Type	Motor Shaft Diameter mm (in.)	Driven Shaft Diameter mm (in.)															
Type	Motor Frame Size	Model	Gear Ratio			04	05	06	F04	08	10	12	14	15	16	18	20	22	24	25	
						φ4 (φ0.1575)	φ5 (φ0.1969)	φ6 (φ0.2362)	φ6.35 (φ0.2500)	φ8 (φ0.3150)	φ10 (φ0.3937)	φ12 (φ0.4724)	φ14 (φ0.5512)	φ15 (φ0.5906)	φ16 (φ0.6299)	φ18 (φ0.7087)	φ20 (φ0.7874)	φ22 (φ0.8661)	φ24 (φ0.9445)	φ25 (φ0.9843)	
TH Geared Type	28 mm (1.10 in.)	CRK523-T□ PK523-T□	7.2, 10, 20, 30	MCS14 05	φ5 (φ0.1969)	●	●	●													
	42 mm (1.65 in.)	RK543-T□ CRK543-T□	3.6, 7.2, 10	MCS20 06	φ6 (φ0.2362)		●	●	●	●	●										
		PK543-T□	20, 30	MCS30 06	φ6 (φ0.2362)			●	●	●	●	●	●								
	60 mm (2.36 in.)	RK564-T□ CRK564-T□	3.6, 7.2	MCS30 08	φ8 (φ0.3150)			●	●	●	●	●	●								
		PK564-T□	10, 20, 30	MCS40 08	φ8 (φ0.3150)				●	●	●	●	●	●	●	●					
90 mm (3.54 in.)	RK596-T□ PK596-T□	3.6, 7.2, 10, 20, 30	MCS55 12	φ12 (φ0.4724)						●	●	●	●	●	●	●	●	●			
PS Geared Type	28 mm (1.10 in.)	CRK523-PS□ PK523-PS□	5, 7.2, 10	MCS20 08	φ8 (φ0.3150)		●	●	●	●											
	42 mm (1.65 in.)	RK545-PS□ CRK545-PS□	5	MCS20 10	φ10 (φ0.3937)		●	●	●	●											
		PK545-PS□	7.2, 10	MCS30 10	φ10 (φ0.3937)			●	●	●	●	●	●								
		RK543-PS□ CRK543-PS□ PK543-PS□	25, 36, 50	MCS40 10	φ10 (φ0.3937)				●	●	●	●	●	●	●	●					
	60 mm (2.36 in.)	RK566-PS□ CRK566-PS□	5	MCS40 12	φ12 (φ0.4724)				●	●	●	●	●	●	●	●	●	●	●		
		PK566-PS□	7.2, 10	MCS55 12	φ12 (φ0.4724)					●	●	●	●	●	●	●	●	●	●	●	
	90 mm (3.54 in.)	RK564-PS□ CRK564-PS□ PK564-PS□	25, 36, 50	MCS55 12	φ12 (φ0.4724)						●	●	●	●	●	●	●	●	●	●	
RK599-PS□ PK599-PS□		5	MCS55 18	φ18 (φ0.7087)							●	●	●	●	●	●	●	●	●		
RK596-PS□ PK596-PS□		7.2, 10	MCS65 18	φ18 (φ0.7087)								●	●	●	●	●	●	●	●		
PN Geared Type	28 mm (1.10 in.)	CRK523-N□ PK523-N□	5, 7.2, 10	MCS20 08	φ8 (φ0.3150)		●	●	●	●											
	42 mm (1.65 in.)	RK544-N□ CRK544-N□	5	MCS20 10	φ10 (φ0.3937)		●	●	●	●											
		PK544-N□	7.2, 10	MCS30 10	φ10 (φ0.3937)			●	●	●	●	●	●								
	60 mm (2.36 in.)	RK566-N□ CRK566-N□	5	MCS40 12	φ12 (φ0.4724)				●	●	●	●	●	●	●	●	●	●	●		
		PK566-N□	7.2, 10	MCS55 12	φ12 (φ0.4724)					●	●	●	●	●	●	●	●	●	●	●	
	90 mm (3.54 in.)	RK564-N□ CRK564-N□ PK564-N□	25, 36, 50	MCS55 12	φ12 (φ0.4724)						●	●	●	●	●	●	●	●	●	●	
		RK599-N□ PK599-N□	5	MCS55 18	φ18 (φ0.7087)						●	●	●	●	●	●	●	●	●	●	
RK596-N□ PK596-N□		7.2, 10	MCS65 18	φ18 (φ0.7087)							●	●	●	●	●	●	●	●	●		
Harmonic Geared Type	20 mm (0.79 in.)	CRK513-H□ PK513-H□	50, 100	MCS14 05	φ5 (φ0.1969)	●	●	●													
	30 mm (1.18 in.)	CRK523-H□ PK523-H□	50, 100	MCS30 08	φ8 (φ0.3150)			●	●	●	●	●	●								
		RK543-H□ CRK543-H□ PK543-H□	50, 100	MCS40 10	φ10 (φ0.3937)				●	●	●	●	●	●	●	●	●	●	●		
	60 mm (2.36 in.)	RK564-H□ CRK564-H□ PK564-H□	50, 100	MCS55 12	φ12 (φ0.4724)						●	●	●	●	●	●	●	●	●		
	90 mm (3.54 in.)	RK596-H□ PK596-H□	50, 100	MCS65 18	φ18 (φ0.7087)								●	●	●	●	●	●	●	●	

● A number indicating the gear ratio is entered where the box (□) is located.
 ● These couplings can also be used with a motor with an encoder.

Introduction

AC Input Motor & Driver

0.36° / Geared
DSTEP AR

0.72° / Geared
AS

0.9° / 1.8°
RK

0.36° / Geared
UMK

0.36° / Geared
DSTEP AR

0.36° / Geared
ASX

0.36° / 0.72° / Geared
CRK

0.9° / 1.8° / Geared
CMK

1.8° / Geared
RBK

0.36° / Geared
PK

0.72° / Geared
PK

0.9° / Geared
PK

1.8° / Geared
PK/PV

0.36° / 0.72° / Geared
PK

Controllers
SCX10
EMP400
/SG8030J

Accessories

● CMK Series, RBK Series, Motor Only PK Series/PV Series

Applicable Product				Coupling Type	Motor Shaft Diameter mm (in.)	Driven Shaft Diameter mm (in.)														
Type	Motor Frame Size	Model	Gear Ratio			04	05	06	F04	08	10	12	14	15	16	18	20	22	24	25
						φ4 (φ0.1575)	φ5 (φ0.1969)	φ6 (φ0.2362)	φ6.35 (φ0.2500)	φ8 (φ0.3150)	φ10 (φ0.3937)	φ12 (φ0.4724)	φ14 (φ0.5512)	φ15 (φ0.5906)	φ16 (φ0.6299)	φ18 (φ0.7087)	φ20 (φ0.7874)	φ22 (φ0.8661)	φ24 (φ0.9445)	φ25 (φ0.9843)
Step Angle 0.9° Standard Type	42 mm (1.65 in.)	CMK243 CMK244 CMK245 PK243 PK245	-	MCS14	05	φ5 (φ0.1969)	●	●	●											
		CMK264 CMK266 PK264 PK266					-	MCS20	F04	φ6.35 (φ0.2500)		●	●	●	●	●				
	CMK268 PK268	MCS30			●	●					●	●								
Step Angle 1.8° High-Torque Type	28 mm (1.10 in.)	CMK223 CMK224 CMK225 RBK223 RBK224 RBK225 PK223 PK224 PK225	-	MCS14	05	φ5 (φ0.1969)	●	●	●											
	35 mm (1.38 in.)	CMK233 CMK235 RBK233 RBK235 PK233 PK235	-	MCS14	05	φ5 (φ0.1969)	●	●	●											
Step Angle 1.8° High-Torque, High-Efficiency Type	42 mm (1.65 in.)	CMK244 RBK244 PK244 PKE243 PKE244	-	MCS14	05	φ5 (φ0.1969)	●	●	●											
		CMK246 RBK246 PK246 PKE245					MCS20	05	φ5 (φ0.1969)		●	●	●	●	●					
	56.4 mm (2.22 in.)	CMK264 PK264	-	MCS20	F04	φ6.35 (φ0.2500)		●	●	●	●	●								
		CMK266 CMK268 PK266 PK268					MCS30	F04	φ6.35 (φ0.2500)			●	●	●	●					
	60 mm (2.36 in.)	PV264	-	MCS20	F04	φ6.35 (φ0.2500)		●	●	●	●									
		PV266 PV267					MCS30	F04	φ6.35 (φ0.2500)			●	●	●						
	PV269	MCS40	08	φ8 (φ0.3150)					●	●	●	●	●	●	●					

- The applicable motor products are listed such that the model can be determined.
- These couplings can also be used with a motor with an encoder.

Stepping Motors

Applicable Product				Coupling Type	Motor Shaft Diameter mm (in.)	Driven Shaft Diameter mm (in.)															
Type	Motor Frame Size	Model	Gear Ratio			04	05	06	F04	08	10	12	14	15	16	18	20	22	24	25	
						φ4 (φ0.1575)	φ5 (φ0.1969)	φ6 (φ0.2362)	φ6.35 (φ0.2500)	φ8 (φ0.3150)	φ10 (φ0.3937)	φ12 (φ0.4724)	φ14 (φ0.5512)	φ15 (φ0.5906)	φ16 (φ0.6299)	φ18 (φ0.7087)	φ20 (φ0.7874)	φ22 (φ0.8661)	φ24 (φ0.9445)	φ25 (φ0.9843)	
Step Angle 1.8° Standard Type	42 mm (1.65 in.)	CMK243 CMK244 PK243 PK244 PK245	-	MCS14 05	φ5 (φ0.1969)	●	●	●													
		CMK256 CMK258 PK256 PK258				-	MCS20 F04	φ6.35 (φ0.2500)		●	●	●	●	●							
	CMK264 CMK266 RBK264 RBK264T RBK266 RBK266T PK264 PK266	-	MCS20 F04	φ6.35 (φ0.2500)						●	●	●	●	●							
	CMK268 RBK268 RBK268T PK268				-	MCS30	φ6.35 (φ0.2500)				●	●	●	●							
	85 mm (3.35 in.)	RBK296T PK296T RBK299T RBK2913T PK299T PK2913T	-	MCS30 14				φ14 (φ0.5512)				●	●	●	●	●	●	●	●	●	
SH Geared Type	28 mm (1.10 in.)	CMK223P-SG □ PK223P-SG □	7.2, 9, 10, 18, 36	MCS14 05	φ5 (φ0.1969)	●	●	●													
		CMK243-SG □ PK243-SG □	3.6, 7.2, 9, 10, 18, 36	MCS14 05 MCS20 05	φ5 (φ0.1969) φ5 (φ0.1969)	●	●	●	●	●											
	60 mm (2.36 in.)	CMK264-SG □ PK264-SG □	3.6, 7.2, 9, 10, 18, 36	MCS30 08 MCS40 08	φ8 (φ0.3150) φ8 (φ0.3150)			●	●	●	●	●	●	●	●	●	●	●			
		RBK223P-PS □ PK223P-PS □	5, 10	MCS20 08	φ8 (φ0.3150)			●	●	●	●										
PL Geared Type	42 mm (1.65 in.)	RBK244P-P □ PK244P-P □	5	MCS20 08	φ8 (φ0.3150)			●	●	●	●	●	●								
		RBK244P-P □ PK244P-P □	10	MCS30 08	φ8 (φ0.3150)			●	●	●	●	●	●	●							
		RBK244P-P □ PK244P-P □	36	MCS40 08	φ8 (φ0.3150)				●	●	●	●	●	●	●	●	●	●			
	60 mm (2.36 in.)	RBK266P-P □ PK266P-P □	5	MCS40 12	φ12 (φ0.4724)				●	●	●	●	●	●	●	●	●	●			
		RBK266P-P □ PK266P-P □	10, 36	MCS55 12	φ12 (φ0.4724)						●	●	●	●	●	●	●	●			

- Enter the gear ratio in the box (□) within the model name.
- The applicable motor products are listed such that the model can be determined.
- These couplings can also be used with a motor with an encoder.

Introduction

AR / Geared / 0.36° / AC Input Motor & Driver / AS / Geared / 0.72° / RK / Geared / 0.9°/1.8° / UMK / Geared / 0.36° / AR / Geared / 0.36° / ASX / Geared / 0.36°/0.72° / CRK / Geared / 0.9°/1.8° / CMK / Geared / 1.8° / RBK / Geared / 0.36° / PK / Geared / 0.72° / PK / Geared / 0.9° / PK / 1.8° / PK/PV / Geared / PK / Controllers / SCX10 / EMP400 / SG8030J / Accessories

Specifications

Model	Dimensions				Key Slot Tolerance b/t	Normal Torque	Mass	Inertia	Static Torsion Spring Constant	Permissible Eccentricity	Permissible Declination	Permissible End Play
	Outer Diameter	Length	Shaft Hole Diameter d1	Shaft Hole Diameter d2								
	mm (in.)	mm (in.)	mm (in.)	mm (in.)								
MCS140404	14 (0.55)	22 (0.87)	$4^{+0.012}_0$ (0.1575 ^{+0.0005})	$4^{+0.012}_0$ (0.1575 ^{+0.0005})	-	2.0 (17.7)	6.7 (0.23)	0.184×10 ⁶ (0.01)	22.9 (200)	0.06 (0.0024)	0.9	$+0.6_0$ (+0.024 ₀)
MCS140405			$4^{+0.012}_0$ (0.1575 ^{+0.0005})	$5^{+0.012}_0$ (0.1969 ^{+0.0005})								
MCS140406			$4^{+0.012}_0$ (0.1575 ^{+0.0005})	$6^{+0.012}_0$ (0.2362 ^{+0.0005})								
MCS140505			$5^{+0.012}_0$ (0.1969 ^{+0.0005})	$5^{+0.012}_0$ (0.1969 ^{+0.0005})								
MCS140506			$5^{+0.012}_0$ (0.2362 ^{+0.0005})	$6^{+0.012}_0$ (0.2362 ^{+0.0005})								
MCS140606			$6^{+0.012}_0$ (0.2362 ^{+0.0005})	$6^{+0.012}_0$ (0.2362 ^{+0.0005})								
MCS200505	20 (0.79)	30 (1.18)	$5^{+0.012}_0$ (0.1969 ^{+0.0005})	$5^{+0.012}_0$ (0.1969 ^{+0.0005})	-	5.0 (44)	19.8 (0.69)	1.059×10 ⁶ (0.06)	51.6 (450)	0.08 (0.0031)	0.9	$+0.8_0$ (+0.031 ₀)
MCS200506			$5^{+0.012}_0$ (0.1969 ^{+0.0005})	$6^{+0.012}_0$ (0.2362 ^{+0.0005})								
MCS2005F04			$5^{+0.012}_0$ (0.1969 ^{+0.0005})	$6.35^{+0.015}_0$ (0.2500 ^{+0.0006})								
MCS200508			$5^{+0.012}_0$ (0.1969 ^{+0.0005})	$8^{+0.015}_0$ (0.3150 ^{+0.0006})								
MCS200510			$5^{+0.012}_0$ (0.1969 ^{+0.0005})	$10^{+0.015}_0$ (0.3937 ^{+0.0006})								
MCS200606			$6^{+0.012}_0$ (0.2362 ^{+0.0005})	$6^{+0.012}_0$ (0.2362 ^{+0.0005})								
MCS2006F04			$6^{+0.012}_0$ (0.2362 ^{+0.0005})	$6.35^{+0.015}_0$ (0.2500 ^{+0.0006})								
MCS200608			$6^{+0.012}_0$ (0.2362 ^{+0.0005})	$8^{+0.015}_0$ (0.3150 ^{+0.0006})								
MCS200610			$6^{+0.012}_0$ (0.2362 ^{+0.0005})	$10^{+0.015}_0$ (0.3937 ^{+0.0006})								
MCS20F04F04			$6.35^{+0.015}_0$ (0.2500 ^{+0.0006})	$6.35^{+0.015}_0$ (0.2500 ^{+0.0006})								
MCS20F0408			$6.35^{+0.015}_0$ (0.2500 ^{+0.0006})	$8^{+0.015}_0$ (0.3150 ^{+0.0006})								
MCS20F0410			$6.35^{+0.015}_0$ (0.2500 ^{+0.0006})	$10^{+0.015}_0$ (0.3937 ^{+0.0006})								
MCS200808			$8^{+0.015}_0$ (0.3150 ^{+0.0006})	$8^{+0.015}_0$ (0.3150 ^{+0.0006})								
MCS200810			$8^{+0.015}_0$ (0.3150 ^{+0.0006})	$10^{+0.015}_0$ (0.3937 ^{+0.0006})								
MCS201010			$10^{+0.015}_0$ (0.3937 ^{+0.0006})	$10^{+0.015}_0$ (0.3937 ^{+0.0006})								
MCS300606			30 (1.18)	35 (1.38)								
MCS3006F04	$6^{+0.012}_0$ (0.2362 ^{+0.0005})	$6.35^{+0.015}_0$ (0.2500 ^{+0.0006})										
MCS300608	$6^{+0.012}_0$ (0.2362 ^{+0.0005})	$8^{+0.015}_0$ (0.3150 ^{+0.0006})										
MCS300610	$6^{+0.012}_0$ (0.2362 ^{+0.0005})	$10^{+0.015}_0$ (0.3937 ^{+0.0006})										
MCS300612	$6^{+0.012}_0$ (0.2362 ^{+0.0005})	$12^{+0.018}_0$ (0.4724 ^{+0.0007})										
MCS300614	$6^{+0.012}_0$ (0.2362 ^{+0.0005})	$14^{+0.018}_0$ (0.5512 ^{+0.0007})										
MCS300615	$6^{+0.012}_0$ (0.2362 ^{+0.0005})	$15^{+0.018}_0$ (0.5906 ^{+0.0007})										
MCS300616	$6^{+0.012}_0$ (0.2362 ^{+0.0005})	$16^{+0.018}_0$ (0.6299 ^{+0.0007})										
MCS30F04F04	$6.35^{+0.015}_0$ (0.2500 ^{+0.0006})	$6.35^{+0.015}_0$ (0.2500 ^{+0.0006})										
MCS30F0408	$6.35^{+0.015}_0$ (0.2500 ^{+0.0006})	$8^{+0.015}_0$ (0.3150 ^{+0.0006})										
MCS30F0410	$6.35^{+0.015}_0$ (0.2500 ^{+0.0006})	$10^{+0.015}_0$ (0.3937 ^{+0.0006})										

Model	Dimensions				Key Slot Tolerance b/t	Normal Torque	Mass	Inertia	Static Torsion Spring Constant	Permissible Eccentricity	Permissible Declination	Permissible End Play
	Outer Diameter	Length	Shaft Hole Diameter d1	Shaft Hole Diameter d2								
MCS300808	30 (1.18)	35 (1.38)	$8^{+0.015}_0$ (0.3150 ^{+0.0006})	$8^{+0.015}_0$ (0.3150 ^{+0.0006})	-	12.5 (110)	44.6 (1.57)	6.057×10^{-6} (0.33)	171.9 (1520)	0.09 (0.0035)	0.9	$+1.0_0$ (+0.039 ₀)
MCS300810			$8^{+0.015}_0$ (0.3150 ^{+0.0006})	$10^{+0.015}_0$ (0.3937 ^{+0.0006})								
MCS300812			$8^{+0.015}_0$ (0.3150 ^{+0.0006})	$12^{+0.018}_0$ (0.4724 ^{+0.0007})								
MCS300814			$8^{+0.015}_0$ (0.3150 ^{+0.0006})	$14^{+0.018}_0$ (0.5512 ^{+0.0007})								
MCS300815			$8^{+0.015}_0$ (0.3150 ^{+0.0006})	$15^{+0.018}_0$ (0.5906 ^{+0.0007})								
MCS300816			$8^{+0.015}_0$ (0.3150 ^{+0.0006})	$16^{+0.018}_0$ (0.6299 ^{+0.0007})								
MCS301010			$10^{+0.015}_0$ (0.3937 ^{+0.0006})	$10^{+0.015}_0$ (0.3937 ^{+0.0006})								
MCS301012			$10^{+0.015}_0$ (0.3937 ^{+0.0006})	$12^{+0.018}_0$ (0.4724 ^{+0.0007})								
MCS301014			$10^{+0.015}_0$ (0.3937 ^{+0.0006})	$14^{+0.018}_0$ (0.5512 ^{+0.0007})								
MCS301015			$10^{+0.015}_0$ (0.3937 ^{+0.0006})	$15^{+0.018}_0$ (0.5906 ^{+0.0007})								
MCS301016			$10^{+0.015}_0$ (0.3937 ^{+0.0006})	$16^{+0.018}_0$ (0.6299 ^{+0.0007})								
MCS301212			$12^{+0.018}_0$ (0.4724 ^{+0.0007})	$12^{+0.018}_0$ (0.4724 ^{+0.0007})								
MCS301214			$12^{+0.018}_0$ (0.4724 ^{+0.0007})	$14^{+0.018}_0$ (0.5512 ^{+0.0007})								
MCS301414			$14^{+0.018}_0$ (0.5512 ^{+0.0007})	$14^{+0.018}_0$ (0.5512 ^{+0.0007})								
MCS301415			$14^{+0.018}_0$ (0.5512 ^{+0.0007})	$15^{+0.018}_0$ (0.5906 ^{+0.0007})								
MCS301416			$14^{+0.018}_0$ (0.5512 ^{+0.0007})	$16^{+0.018}_0$ (0.6299 ^{+0.0007})								
MCS400808	40 (1.57)	66 (2.60)	$8^{+0.015}_0$ (0.3150 ^{+0.0006})	$8^{+0.015}_0$ (0.3150 ^{+0.0006})	$\phi 8$ ($\phi 0.3150$) b: 2 ± 0.0125 (0.0787 ± 0.0005) t: $1^{+0.1}_0$ ($0.039^{+0.0039}_0$)	17.0 (150)	139 (4.9)	42.29×10^{-6} (2.3)	859.5 (7600)	0.06 (0.0024)	0.9	$+1.2_0$ (+0.047 ₀)
MCS400810			$8^{+0.015}_0$ (0.3150 ^{+0.0006})	$10^{+0.015}_0$ (0.3937 ^{+0.0006})								
MCS400812			$8^{+0.015}_0$ (0.3150 ^{+0.0006})	$12^{+0.018}_0$ (0.4724 ^{+0.0007})								
MCS400814			$8^{+0.015}_0$ (0.3150 ^{+0.0006})	$14^{+0.018}_0$ (0.5512 ^{+0.0007})								
MCS400815			$8^{+0.015}_0$ (0.3150 ^{+0.0006})	$15^{+0.018}_0$ (0.5906 ^{+0.0007})								
MCS400816			$8^{+0.015}_0$ (0.3150 ^{+0.0006})	$16^{+0.018}_0$ (0.6299 ^{+0.0007})								
MCS400818			$8^{+0.015}_0$ (0.3150 ^{+0.0006})	$18^{+0.018}_0$ (0.7087 ^{+0.0007})								
MCS400820			$8^{+0.015}_0$ (0.3150 ^{+0.0006})	$20^{+0.021}_0$ (0.7874 ^{+0.0008})								
MCS401010			$10^{+0.015}_0$ (0.3937 ^{+0.0006})	$10^{+0.015}_0$ (0.3937 ^{+0.0006})								
MCS401012			$10^{+0.015}_0$ (0.3937 ^{+0.0006})	$12^{+0.018}_0$ (0.4724 ^{+0.0007})								
MCS401014			$10^{+0.015}_0$ (0.3937 ^{+0.0006})	$14^{+0.018}_0$ (0.5512 ^{+0.0007})								
MCS401015			$10^{+0.015}_0$ (0.3937 ^{+0.0006})	$15^{+0.018}_0$ (0.5906 ^{+0.0007})								
MCS401016			$10^{+0.015}_0$ (0.3937 ^{+0.0006})	$16^{+0.018}_0$ (0.6299 ^{+0.0007})								
MCS401018			$10^{+0.015}_0$ (0.3937 ^{+0.0006})	$18^{+0.018}_0$ (0.7087 ^{+0.0007})								
MCS401020			$10^{+0.015}_0$ (0.3937 ^{+0.0006})	$20^{+0.021}_0$ (0.7874 ^{+0.0008})								

Introduction

AC Input Motor & Driver

0.36° / Geared
AR
0.72° / Geared
RK
0.9°/1.8°
UMK
0.36° / Geared
AR
0.36° / Geared
ASX
0.36°/0.72° / Geared
CRK
0.9°/1.8° / Geared
CMK
1.8° / Geared
RBK
0.36°
PK
0.72°
PK
0.9°
PK
1.8°
PK/PV
Geared
PK
Controllers
SCX10 / EMP400 / SG8030J
Accessories

Model	Dimensions					Normal Torque	Mass	Inertia	Static Torsion Spring Constant	Permissible Eccentricity	Permissible Declination	Permissible End Play	
	Outer Diameter	Length	Shaft Hole Diameter d1	Shaft Hole Diameter d2	Key Slot Tolerance b/t								
	mm (in.)	mm (in.)	mm (in.)	mm (in.)	mm (in.)								
MCS401212	40 (1.57)	66 (2.60)	12 ^{+0.018} ₀ (0.4724 ^{+0.0007})	12 ^{+0.018} ₀ (0.4724 ^{+0.0007})		17.0 (150)	139 (4.9)	42.29×10 ⁶ (2.3)	859.5 (7600)	0.06 (0.0024)	0.9	+1.2 0 (+0.047 0)	
MCS401214			12 ^{+0.018} ₀ (0.4724 ^{+0.0007})	14 ^{+0.018} ₀ (0.5512 ^{+0.0007})									
MCS401215			12 ^{+0.018} ₀ (0.4724 ^{+0.0007})	15 ^{+0.018} ₀ (0.5906 ^{+0.0007})									
MCS401216			12 ^{+0.018} ₀ (0.4724 ^{+0.0007})	16 ^{+0.018} ₀ (0.6299 ^{+0.0007})									
MCS401218			12 ^{+0.018} ₀ (0.4724 ^{+0.0007})	18 ^{+0.018} ₀ (0.7087 ^{+0.0007})									
MCS401220			12 ^{+0.018} ₀ (0.4724 ^{+0.0007})	20 ^{+0.021} ₀ (0.7874 ^{+0.0008})									
MCS551212	55 (2.17)	78 (3.07)	12 ^{+0.018} ₀ (0.4724 ^{+0.0007})	12 ^{+0.018} ₀ (0.4724 ^{+0.0007})	φ12 (φ0.4724) b: 4±0.015 (0.0787±0.0006) t: 1.8 ^{+0.1} ₀ (0.071 ^{+0.0039})	60.0 (530)	282 (10)	109.1×10 ⁶ (6)	2063 (18200)	0.1 (0.0039)	0.9	+1.4 0 (+0.055 0)	
MCS551214			12 ^{+0.018} ₀ (0.4724 ^{+0.0007})	14 ^{+0.018} ₀ (0.5512 ^{+0.0007})									
MCS551215			12 ^{+0.018} ₀ (0.4724 ^{+0.0007})	15 ^{+0.018} ₀ (0.5906 ^{+0.0007})									
MCS551216			12 ^{+0.018} ₀ (0.4724 ^{+0.0007})	16 ^{+0.018} ₀ (0.6299 ^{+0.0007})									
MCS551218			12 ^{+0.018} ₀ (0.4724 ^{+0.0007})	18 ^{+0.018} ₀ (0.7087 ^{+0.0007})									
MCS551220			12 ^{+0.018} ₀ (0.4724 ^{+0.0007})	20 ^{+0.021} ₀ (0.7874 ^{+0.0008})									
MCS551222			12 ^{+0.018} ₀ (0.4724 ^{+0.0007})	22 ^{+0.021} ₀ (0.8661 ^{+0.0008})									
MCS551224			12 ^{+0.018} ₀ (0.4724 ^{+0.0007})	24 ^{+0.021} ₀ (0.9449 ^{+0.0008})									
MCS551414			14 ^{+0.018} ₀ (0.5512 ^{+0.0007})	14 ^{+0.018} ₀ (0.5512 ^{+0.0007})									φ14 (φ0.5512) b: 5±0.015 (0.1969±0.0006) t: 2.3 ^{+0.1} ₀ (0.091 ^{+0.0039})
MCS551415			14 ^{+0.018} ₀ (0.5512 ^{+0.0007})	15 ^{+0.018} ₀ (0.5906 ^{+0.0007})									φ15 (φ0.5906) b: 5±0.015 (0.1969±0.0006) t: 2.3 ^{+0.1} ₀ (0.091 ^{+0.0039})
MCS551416			14 ^{+0.018} ₀ (0.5512 ^{+0.0007})	16 ^{+0.018} ₀ (0.6299 ^{+0.0007})									φ16 (φ0.6299) b: 5±0.015 (0.1969±0.0006) t: 2.3 ^{+0.1} ₀ (0.091 ^{+0.0039})
MCS551418			14 ^{+0.018} ₀ (0.5512 ^{+0.0007})	18 ^{+0.018} ₀ (0.7087 ^{+0.0007})									φ18 (φ0.7078) b: 6±0.015 (0.2362±0.0006) t: 2.8 ^{+0.1} ₀ (0.110 ^{+0.0039})
MCS551420			14 ^{+0.018} ₀ (0.5512 ^{+0.0007})	20 ^{+0.021} ₀ (0.7874 ^{+0.0008})									φ20 (φ0.7874) b: 6±0.015 (0.2362±0.0006) t: 2.8 ^{+0.1} ₀ (0.110 ^{+0.0039})
MCS551422			14 ^{+0.018} ₀ (0.5512 ^{+0.0007})	22 ^{+0.021} ₀ (0.8661 ^{+0.0008})									φ22 (φ0.8661) b: 6±0.015 (0.2362±0.0006) t: 2.8 ^{+0.1} ₀ (0.110 ^{+0.0039})
MCS551424			14 ^{+0.018} ₀ (0.5512 ^{+0.0007})	24 ^{+0.021} ₀ (0.9449 ^{+0.0008})									φ24 (φ0.9449) b: 8±0.018 (0.3150±0.0007) t: 3.3 ^{+0.2} ₀ (0.130 ^{+0.0079})
MCS551518			15 ^{+0.018} ₀ (0.5906 ^{+0.0007})	18 ^{+0.018} ₀ (0.7087 ^{+0.0007})									φ22 (φ0.8661) b: 6±0.015 (0.2362±0.0006) t: 2.8 ^{+0.1} ₀ (0.110 ^{+0.0039})
MCS551618			16 ^{+0.018} ₀ (0.6299 ^{+0.0007})	18 ^{+0.018} ₀ (0.7087 ^{+0.0007})									φ24 (φ0.9449) b: 8±0.018 (0.3150±0.0007) t: 3.3 ^{+0.2} ₀ (0.130 ^{+0.0079})
MCS551818			18 ^{+0.018} ₀ (0.7087 ^{+0.0007})	18 ^{+0.018} ₀ (0.7087 ^{+0.0007})									φ25 (φ0.9843) b: 8±0.018 (0.3150±0.0007) t: 3.3 ^{+0.2} ₀ (0.130 ^{+0.0079})
MCS551820			18 ^{+0.018} ₀ (0.7087 ^{+0.0007})	20 ^{+0.021} ₀ (0.7874 ^{+0.0008})									φ25 (φ0.9843) b: 8±0.018 (0.3150±0.0007) t: 3.3 ^{+0.2} ₀ (0.130 ^{+0.0079})
MCS551822			18 ^{+0.018} ₀ (0.7087 ^{+0.0007})	22 ^{+0.021} ₀ (0.8661 ^{+0.0008})									
MCS551824	18 ^{+0.018} ₀ (0.7087 ^{+0.0007})	24 ^{+0.021} ₀ (0.9449 ^{+0.0008})											
MCS651618	65 (2.56)	90 (3.54)	16 ^{+0.018} ₀ (0.6299 ^{+0.0007})	18 ^{+0.018} ₀ (0.7087 ^{+0.0007})		160 (1410)	535 (18.9)	417.1×10 ⁶ (22.8)	3438 (30000)	0.11 (0.0043)	0.9	+1.5 0 (+0.059 0)	
MCS651818			18 ^{+0.018} ₀ (0.7087 ^{+0.0007})	18 ^{+0.018} ₀ (0.7087 ^{+0.0007})									
MCS651820			18 ^{+0.018} ₀ (0.7087 ^{+0.0007})	20 ^{+0.021} ₀ (0.7874 ^{+0.0008})									
MCS651822			18 ^{+0.018} ₀ (0.7087 ^{+0.0007})	22 ^{+0.021} ₀ (0.8661 ^{+0.0008})									
MCS651824			18 ^{+0.018} ₀ (0.7087 ^{+0.0007})	24 ^{+0.021} ₀ (0.9449 ^{+0.0008})									

Model	Dimensions				Key Slot Tolerance b/t mm (in.)	Normal Torque N·m (lb-in)	Mass g (oz.)	Inertia kg·m ² (oz-in ²)	Static Torsion Spring Constant N·m/rad (lb-in/rad)	Permissible Eccentricity mm (in.)	Permissible Declination deg	Permissible End Play mm (in.)
	Outer Diameter mm (in.)	Length mm (in.)	Shaft Hole Diameter d1 mm (in.)	Shaft Hole Diameter d2 mm (in.)								
MCS651825	65 (2.56)	90 (3.54)	18 ^{+0.018} ₀ (0.7087 ^{+0.0007})	25 ^{+0.021} ₀ (0.9843 ^{+0.0008})	(See page A-418)	160 (1410)	535 (18.9)	417.1×10 ⁻⁶ (22.8)	3438 (30000)	0.11 (0.0043)	0.9	+1.5 0 (+0.059 0)
MCS652020			20 ^{+0.021} ₀ (0.7874 ^{+0.0008})	20 ^{+0.021} ₀ (0.7874 ^{+0.0008})								
MCS652022			20 ^{+0.021} ₀ (0.7874 ^{+0.0008})	22 ^{+0.021} ₀ (0.8661 ^{+0.0008})								
MCS652024			20 ^{+0.021} ₀ (0.7874 ^{+0.0008})	24 ^{+0.021} ₀ (0.9449 ^{+0.0008})								
MCS652025			20 ^{+0.021} ₀ (0.7874 ^{+0.0008})	25 ^{+0.021} ₀ (0.9843 ^{+0.0008})								

Dimensions Unit = mm (in.)

MCS14

Mass: 6.7 g (0.23 oz.)

DXF B493

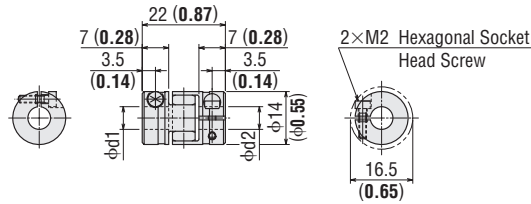

MCS20

Mass: 19.8 g (0.69 oz.)

DXF B494

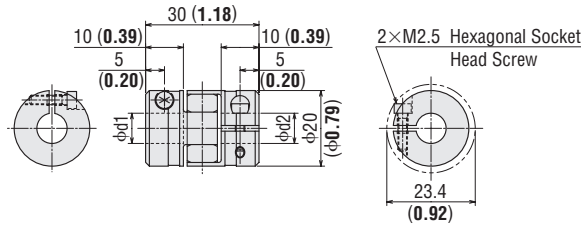

MCS30

Mass: 44.6 g (1.57 oz.)

DXF B495

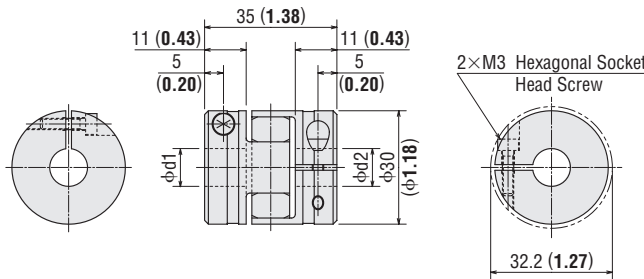

Introduction	AC Input Motor & Driver	Motor Only
AR DSTEP /Geared AS	0.36° /Geared AS	0.9°/1.8°
RK	0.72° /Geared	1.8° /Geared
UMK	0.9°/1.8°	1.8° /Geared
AR DSTEP /Geared AS	0.36° /Geared AS	0.9°/1.8° /Geared
ASX	0.36°	1.8° /Geared
CRK	0.36°/0.72° /Geared	1.8° /Geared
CMK	0.9°/1.8° /Geared	1.8° /Geared
RBK	1.8° /Geared	1.8° /Geared
PK	0.36°	1.8° /Geared
PK	0.72°	1.8° /Geared
PK	0.9°	1.8° /Geared
PK/PV	1.8°	1.8° /Geared
PK	Geared	1.8° /Geared
Controllers SCX10 /EMP400 /SG8030J		1.8° /Geared
Accessories		1.8° /Geared

MCS40

Mass: 139 g (4.9 oz.)

DXF B496

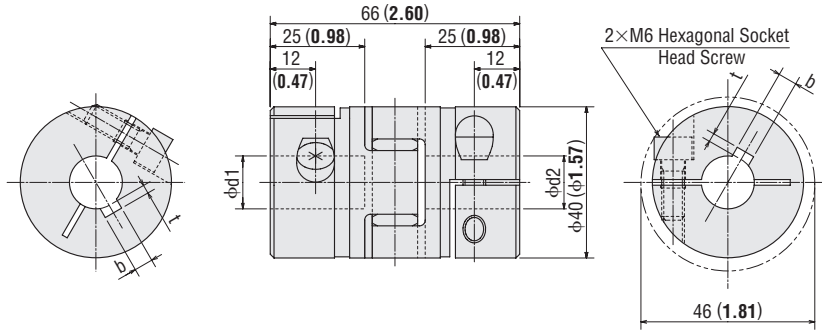

MCS55

Mass: 282 g (10 oz.)

DXF B497

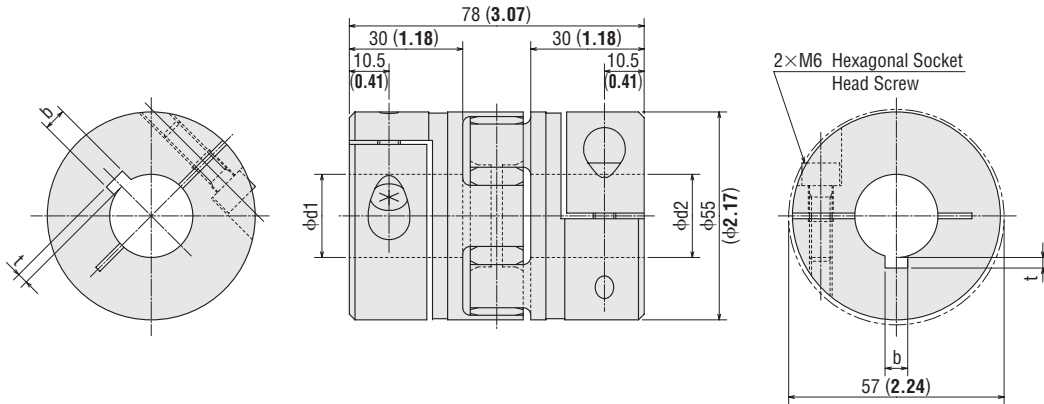

MCS65

Mass: 535 g (18.9 oz.)

DXF B498

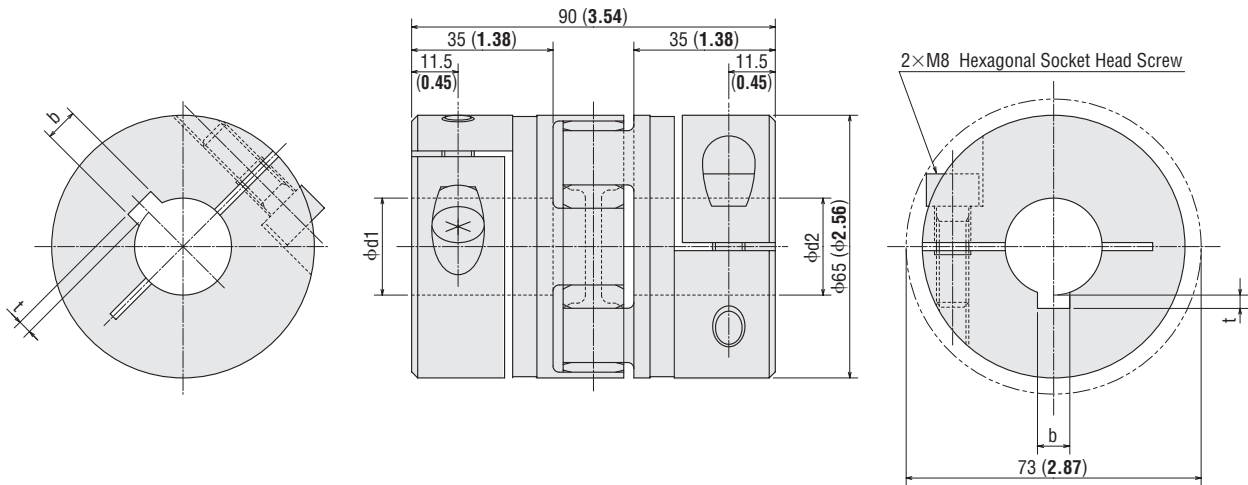

Clean Dampers RoHS

Mechanical dampers suppress stepping motor vibration and improve high-speed performance. An inertia body and silicon gel are hermetically sealed in a plastic case.

Features

- Excellent vibration absorption
The doughnut-shaped internal inertia body and silicon gel absorb vibration. This feature enables a stable damping effect.
- Since there is no frictional dust as in conventional magnetic dampers, it can be used in environments where higher degrees of cleanliness is needed.
- High reliability.
- Holds up well in harsh environments and changes little with age because the silicon gel and plastic case used are heat resistant.
- Machine part is sealed hermetically in a plastic case. This ensures safety and doesn't generate noise.
- This clean damper is an accessory for double shaft types. It can be used with various geared motors of double shaft type.

Product Line

Model
D4CL-5.0F
D6CL-6.3F
D6CL-8.0F
D9CL-12.7F
D9CL-14F

Installation of the Clean Damper

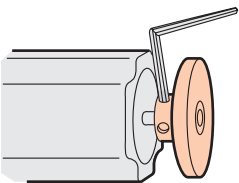

Dimensions Unit = mm (in.)

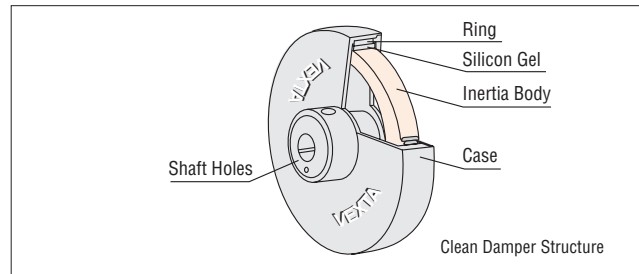
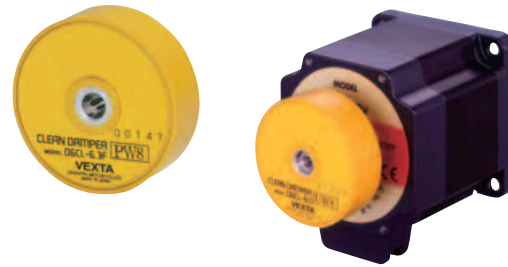
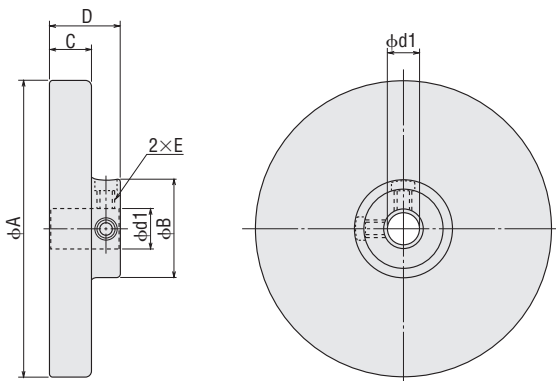

Specifications

Model	Inertia kg·m ² (oz-in ²)	Mass g (lb.)
D4CL-5.0F	34×10 ⁻⁷ (0.186)	24 (0.053)
D6CL-6.3F	140×10 ⁻⁷ (0.77)	62 (0.14)
D6CL-8.0F	140×10 ⁻⁷ (0.77)	61 (0.13)
D9CL-12.7F	870×10 ⁻⁷ (4.8)	105 (0.23)
D9CL-14F	870×10 ⁻⁷ (4.8)	105 (0.23)

Ambient Temperature: -20~+80°C (-4~+176°F)

Point the mounting screws of the clean damper toward the motor case, fasten to the shaft and tighten the damper's mounting screws (two places) with a hexagonal wrench to secure it to the shaft.

Model	D4CL-5.0F	D6CL-6.3F	D6CL-8.0F	D9CL-12.7F	D9CL-14F
Tightening Torque N·m (oz-in)	0.4 (56)			1.5 (210)	

Notes

- There are mounting screws with hexagonal holes in two damper locations, so tighten them both before running the motor.
- The damper rotates at the same speed as the motor shaft, so do not touch it while the motor is running.

Model	φd1	φA	φB	C	D	E
D4CL-5.0F	5 ^{+0.018} ₀ (0.1969 ^{+0.0007} ₀)	φ36±0.5 (φ1.42±0.02)	φ13±0.5 (φ0.51±0.02)	9±0.3 (0.354±0.012)	15±0.5 (0.591±0.02)	M3
D6CL-6.3F	6.35 ^{+0.022} ₀ (0.2500 ^{+0.0008} ₀)	φ44.5±0.5 (φ1.75±0.02)	φ20±0.5 (φ0.79±0.02)	15±0.3 (0.591±0.012)	22±0.5 (0.87±0.02)	M4
D6CL-8.0F	8 ^{+0.022} ₀ (0.3150 ^{+0.0008} ₀)	φ44.5±0.5 (φ1.75±0.02)	φ20±0.5 (φ0.79±0.02)	15±0.3 (0.591±0.012)	22±0.5 (0.87±0.02)	M4
D9CL-12.7F	12.7 ^{+0.027} ₀ (0.500 ^{+0.0011} ₀)	φ79.5±0.5 (φ3.13±0.02)	φ26±0.5 (φ1.02±0.02)	11±0.3 (0.433±0.012)	19±0.5 (0.75±0.02)	M4
D9CL-14F	14 ^{+0.027} ₀ (0.5512 ^{+0.0011} ₀)	φ79.5±0.5 (φ3.13±0.02)	φ26±0.5 (φ1.02±0.02)	11±0.3 (0.433±0.012)	19±0.5 (0.75±0.02)	M4

● Clean Damper Selection Table

Model	Applicable Product			
	<i>α</i> STEP AR Series (AC and DC Input)	RK Series, CRK Series	CMK Series, RBK Series	Motor Only PK Series, PV Series
D4CL-5.0F	AR46	RK543 RK544 RK545 CRK523 CRK524 CRK525 CRK543 CRK544 CRK545 CRK546	CMK223 CMK224 CMK225 CMK233 CMK235 CMK243 CMK244 CMK245 CMK246 RBK223 RBK224 RBK225 RBK233 RBK235 RBK244 RBK246	PK223 PK224 PK225 PK233 PK235 PKE243 PKE244 PKE245 PK243 PK244 PK245 PK246 PK523 PK524 PK525 PK543 PK544 PK545 PK546
D6CL-6.3F	-	-	CMK256 CMK258 CMK264 CMK266 CMK268 RBK264 RBK266 RBK268	PK256 PK258 PK264 PK266 PK268 PV264 PV266 PV267 PV269
D6CL-8.0F	AR66 AR69 AR98 AR911	RK564 RK566 RK569 CRK564 CRK566 CRK569	-	PK564 PK566 PK569
D9CL-12.7F	-	-	RBK296 RBK299 RBK2913	PK296 PK299 PK2913
D9CL-14F	-	RK596 RK599 RK5913	-	PK596 PK599 PK5913

● The applicable motor products are listed such that the model can be determined.

Motor Mounting Brackets RoHS

Mounting brackets are convenient for installation and securing a stepping motor and geared stepping motor.



Product Line

Standard Type, High-Torque Type

Material: Aluminum alloy

Model	Applicable Product						
	<i>α</i> STEP AR Series (AC and DC Input)	RK Series	CRK Series	CMK Series	RBK Series	Motor Only PK Series, PV Series	Low-Speed Synchronous Motors SMK Series
PAFOP	AR46	RK543 RK544 RK545	CRK543 CRK544 CRK545 CRK546	CMK243 CMK244 CMK245 CMK246	RBK244 RBK246	PK543 PK544 PK545 PK546 PK243 PK244 PK245 PKE243 PKE244 PKE245	SMK014
PALOPA							SMK014 SMK014M
PAL2P-5A	AR66 AR69	RK564 RK566 RK569	CRK564 CRK566 CRK569	-	-	PK564 PK566 PK569	-
PAL2P-2	-	-	-	CMK264 CMK266 CMK268	RBK264 RBK266 RBK268	PK264 PK266 PK268 PV264 PV266 PV267 PV269	SMK237
PAL4P-5A	AR98 AR911	RK596 RK599 RK5913	-	-	-	PK596 PK599 PK5913	-
PAL4P-2	-	-	-	-	RBK296 RBK299 RBK2913	PK296 PK299 PK2913	SMK5100 SMK5160

- The applicable motor products are listed such that the model can be determined.
- The mounting bracket base is built with holes large enough to allow for alignment adjustments in the horizontal direction.
- These mounting brackets can be perfectly fitted to the pilot of the stepping motors. (Except for **PALOPA**)
- These mounting brackets can also be used with a motor with an encoder.

Note

- They cannot be used with geared stepping motors.

Geared Type

Material: Aluminum alloy

Model	Applicable Product					
	<i>α</i> STEP AR Series (AC and DC Input)	RK Series	CRK Series	CMK Series	RBK Series	Motor Only PK Series, PV Series
SOLOA-A	-	-	-	CMK243-SG <input type="checkbox"/>	-	PK243-SG <input type="checkbox"/>
SOLOB-A	AR46-T <input type="checkbox"/>	RK543-T <input type="checkbox"/>	CRK543-T <input type="checkbox"/>	-	RBK244-P <input type="checkbox"/>	PK543-T <input type="checkbox"/> PK244-P <input type="checkbox"/>
SOL2A-A	AR66-T <input type="checkbox"/>	RK564-T <input type="checkbox"/>	CRK564-T <input type="checkbox"/>	CMK264-SG <input type="checkbox"/>	-	PK564-T <input type="checkbox"/> PK264-SG <input type="checkbox"/>
SOL5B-A	AR98-T <input type="checkbox"/>	RK596-T <input type="checkbox"/>	-	-	-	PK596-T <input type="checkbox"/> PK296-SG <input type="checkbox"/>
PLA60G	AR66-PS <input type="checkbox"/> AR66-N <input type="checkbox"/>	RK564-PS <input type="checkbox"/> RK566-PS <input type="checkbox"/> RK564-N <input type="checkbox"/> RK566-N <input type="checkbox"/>	CRK564-PS <input type="checkbox"/> CRK566-PS <input type="checkbox"/> CRK564-N <input type="checkbox"/> CRK566-N <input type="checkbox"/>	-	-	PK564-PS <input type="checkbox"/> PK566-PS <input type="checkbox"/> PK564-N <input type="checkbox"/> PK566-N <input type="checkbox"/> PK264-P <input type="checkbox"/> PK266-P <input type="checkbox"/>
PLA60H	AR66-H <input type="checkbox"/>	RK564-H <input type="checkbox"/>	CRK564-H <input type="checkbox"/>	-	-	PK564-H <input type="checkbox"/>
PLA90G	AR98-PS <input type="checkbox"/> AR98-N <input type="checkbox"/>	RK596-PS <input type="checkbox"/> RK599-PS <input type="checkbox"/> RK596-N <input type="checkbox"/> RK599-N <input type="checkbox"/>	-	-	-	PK596-PS <input type="checkbox"/> PK599-PS <input type="checkbox"/> PK596-N <input type="checkbox"/> PK599-N <input type="checkbox"/>
PLA90H	AR98-H <input type="checkbox"/>	RK596-H <input type="checkbox"/>	-	-	-	PK596-H <input type="checkbox"/>

- A number indicating the gear ratio is entered where the box () is located.
- These mounting brackets can also be used with a motor with an encoder.

Introduction
 AC Input Motor & Driver
 0.36° / Geared
 0.72° / Geared
 0.9° / 1.8°
 DC Input Motor & Driver
 0.36° / Geared
 0.36° / Geared
 0.36° / 0.72° / Geared
 0.9° / 1.8° / Geared
 1.8° / Geared
 Motor Only
 0.9°
 1.8° / PV
 Geared
 Controllers
 SCX10
 EMP400
 /SG8030J
 Accessories

Motor Installation Direction

The motor cable comes out at right angles to the motor. Orient the motor so that the cable faces either upward or sideways.

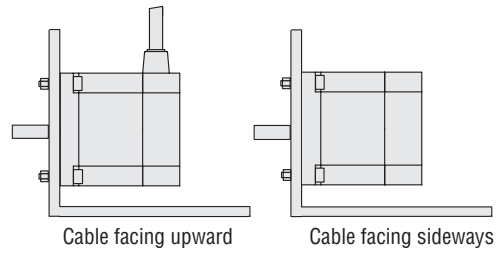

Mounting the Motor

1 PAL2P-5A, PAL2P-2, PAL4P-5A, PAL4P-2

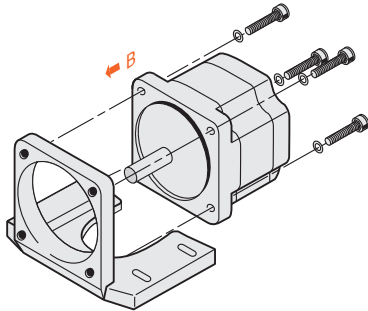

- ① Use the screws provided to secure the motor to the mounting bracket.
- ② Attach the motor from the direction shown by the arrow (B).

2 PAL0PA, SOLOA-A, SOLOB-A, SOL2A-A, SOL5B-A

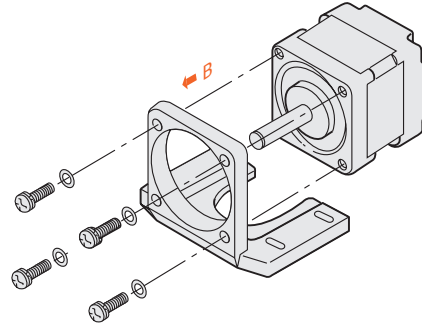

- ① Use the screws provided to secure the motor to the mounting bracket.
(No screws are supplied for **SOLOA-A**, **SOLOB-A**, **SOL2A-A** and **SOL5B-A**. Provide appropriate screws separately.)
- ② Attach the motor from the direction shown by the arrow (B).

3 PAFOP

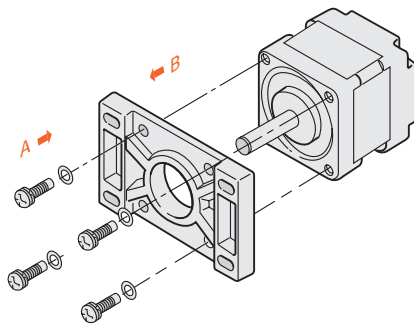

- ① Use the screws provided to secure the motor to the mounting bracket.
- ② Attach motor from the direction shown by either arrow (A) or arrow (B).

4 PLA60G, PLA60H, PLA90G, PLA90H*

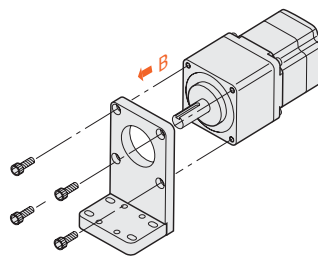

- ① Use the screws provided to secure the motor to the mounting bracket.
- ② Attach the motor from the direction shown by the arrow (B).
*For **PLA90H**, the screws must be attached from the direction shown by the arrow (B).

SOL2A-A

Mass: 120 g (4.2 oz.)

DXF B268

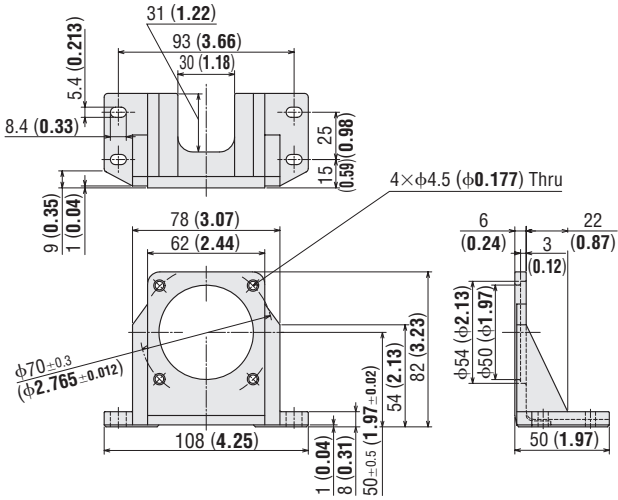

SOL5B-A

Mass: 270 g (9.5 oz.)

DXF B271

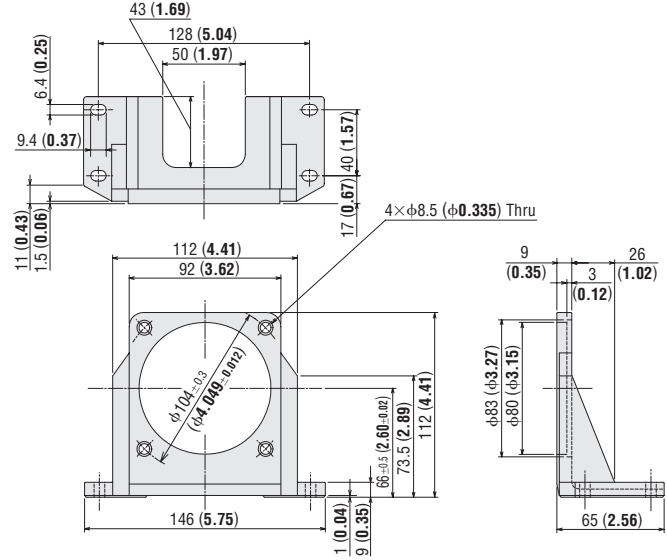

PLA60G

Mass: 0.7 kg (1.54 lb.)

DXF B634

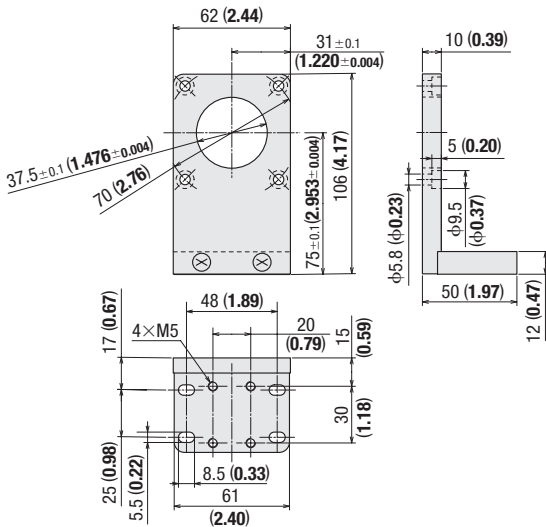

PLA60H

Mass: 0.7 kg (1.54 lb.)

DXF B635

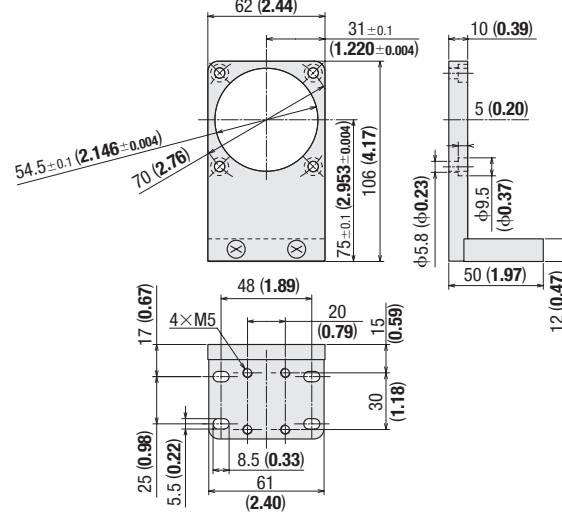

Introduction	AR	AS	RK	UMK	AR	ASX	CRK	CMK	RBK	PK	PK	PK	PK	PK/PV	PK	Controllers SCX10 EMP400 /SG8030J	Accessories
	0.36° /Geared	0.36° /Geared	0.72° /Geared	0.9°/1.8°	0.36° /Geared	0.36°	0.36°/0.72° /Geared	0.9°/1.8° /Geared	1.8° /Geared	0.36°	0.72°	0.9°	1.8°	Geared			

PLA90G

Mass: 1.6 kg (3.5 lb.)

DXF B637

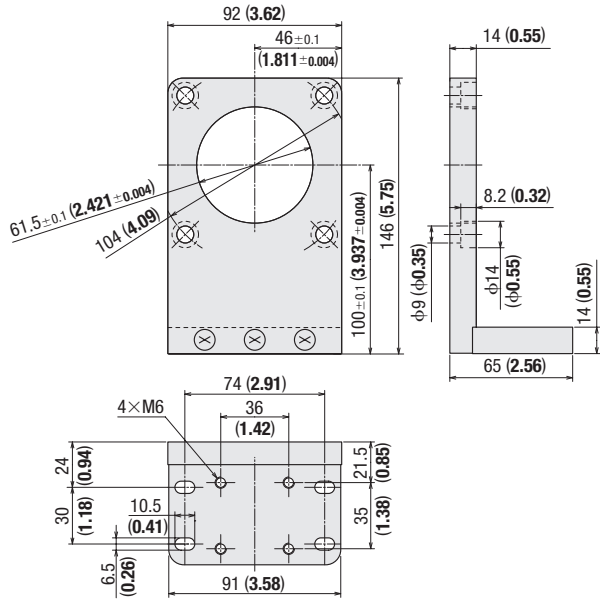

PLA90H

Mass: 1.6 kg (3.5 lb.)

DXF B638

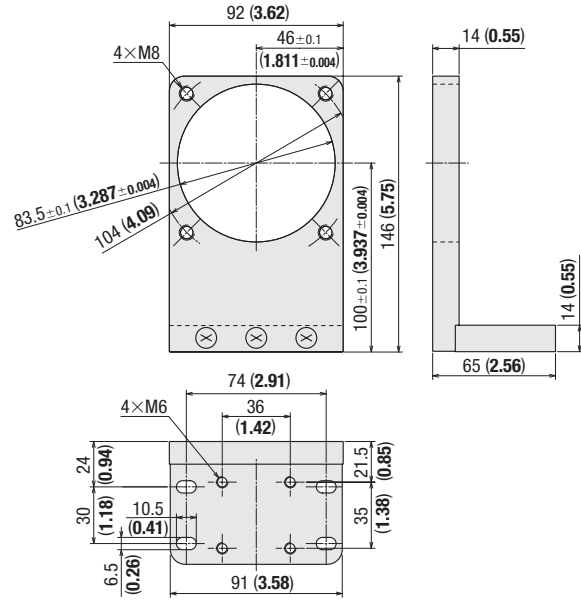

DIN Rail Mounting Plate RoHS

This mounting plate is convenient for installing the drivers of **RBK** Series on DIN rails with ease.

Product Line

Model	Applicable Product
PADP01	RBK Series Driver

Dimensions Unit = mm (in.)

DXF A1019

Mass: 20 g (0.71 oz.)

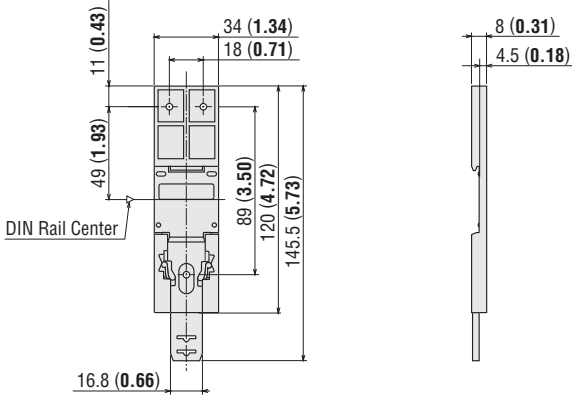

- Screws (Included)
M3P0.5 Length 8 mm (0.31 in.) ... 3 pieces

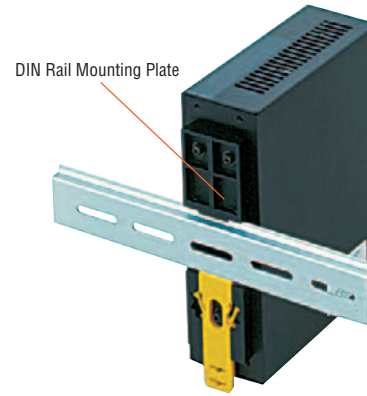

Introduction
AC Input Motor & Driver
AR 0.36° / Geared
AS 0.72° / Geared
UMK 0.9°/1.8°
AR 0.36° / Geared
ASX 0.36° / Geared
CRK 0.36°/0.72° / Geared
CMK 0.9°/1.8° / Geared
RBK 1.8° / Geared
PK 0.36°
PK 0.72°
PK 0.9°
PK/PV 1.8°
PK Geared
Controllers SCX10 EMP400 /5G8030J
Accessories

Control Module RoHS

Features

The internal driver parameter settings and data settings can be established and changed. They can also be used for speed and I/O monitoring, teaching, and so on.

- The settings and monitoring details depend on the applicable products.



Product Line

Model	Applicable Product
OPX-2A	AR Series (AC input and DC input)

Specifications

Display	LED
Cable Length	5 m (16.4 ft.)
Ambient Temperature	0~+40°C (+32~+104°F) (non-condensing)

Dimensions Unit = mm (in.)

Control Module

Mass: 0.25 kg (0.55 lb.) DXF B453

Panel Cut-Out for Control Module

[Thickness of the mounting plate: 1 ~ 3 mm (0.04 ~ 0.12 in.)]

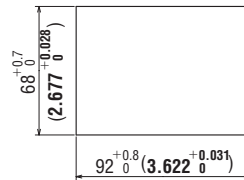
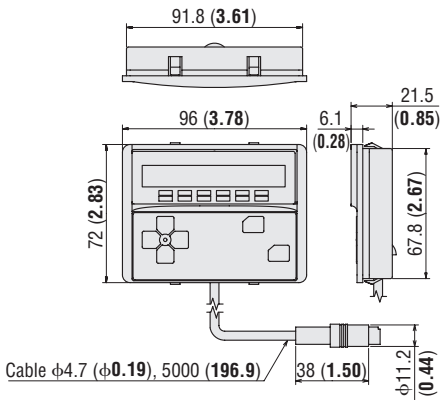

Data Setting Software RoHS

Operation data and various parameters can be established and edited on the computer, as well as I/O and operating speed waveforms monitored.

● The settings and monitoring details depend on the applicable products.



Product Line

Model	Applicable Product
MEXE02	AR Series (AC input and DC input)

Connection between Computer and Driver

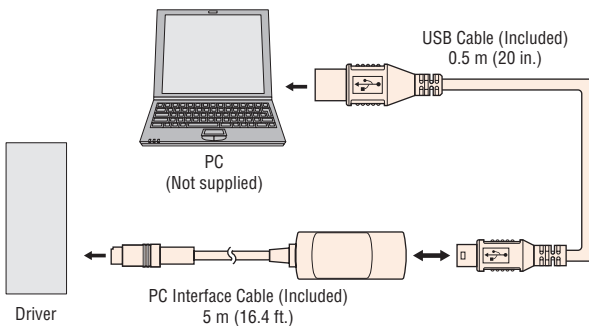

Operating Environment

Operating Systems	The OS supports 32-bit (x86) and 64-bit (x64) versions only. Windows® 2000 Professional Service Pack 4 or later*1 Windows® XP Home Edition Service Pack 3 or later Windows® XP Professional Service Pack 2 Windows® XP Professional Service Pack 3*2 or later Windows® Vista Home Basic Service Pack 2 or later Windows® Vista Home Premium Service Pack 2 or later Windows® Vista Business Service Pack 2 or later Windows® Vista Ultimate Service Pack 2 or later Windows® Vista Enterprise Service Pack 2 or later Windows® 7 Starter Service Pack 1 or later Windows® 7 Home Premium Service Pack 1 or later Windows® 7 Professional Service Pack 1 or later Windows® 7 Ultimate Service Pack 1 or later Windows® 7 Enterprise Service Pack 1 or later
CPU*3	Intel Core Processor 2 GHz or more (The OS must be supported.)
Memory*3	32-bit (x86) version: 1 GB or more 64-bit (x64) version: 2 GB or more
Hard Disk*4	Available disk space of 30 MB or more
Disk Device	CD-ROM drive
Serial Interface	USB 1.1 1 port

*1 Rollup 1 must be applied.

*2 Service Pack 3 supports 32-bit (x86) version only

*3 The OS operating conditions must be satisfied.

*4 Microsoft .NET Framework 2.0 Service Pack 2 is required to use **MEXE02**. If it is not already installed, it will be installed automatically, in which case up to 500 MB in additional space is required.

● Windows and Windows Vista are registered trademark of Microsoft Corporation in the United States and other countries. Pentium is a trademark of Intel Corporation.

Introduction	
AR /Geared	0.36°
AS /Geared	0.72°
ASX	0.9°/1.8°
UMK	0.9°/1.8°
AR /Geared	0.36°
ASX	0.36°
CRK /Geared	0.36°/0.72°
CMK /Geared	0.9°/1.8°
RBK /Geared	1.8°
PK	0.36°
PK	0.72°
PK	0.9°
PK/PV	1.8°
PK	Geared
SCX10 /EMP400 /SG8030J	Controllers
	Accessories

Accessories for EMP Series Controller

We have a range of optional cables that achieve one-touch connection between the **EMP400** Series and peripherals, as well as an operator interface unit used for teaching operation.

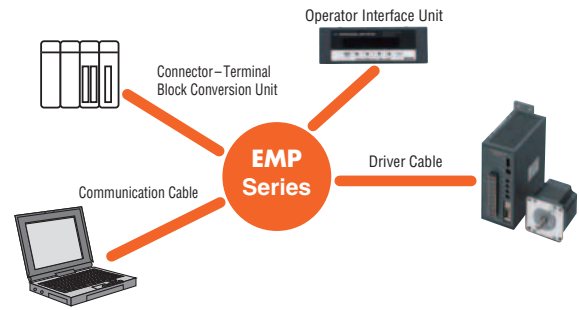

Control Module **OP300** (RoHS)

Set the travel amount via teaching or monitor the current position. The unit comes with a 2 m (6.6 ft.) cable for connection with the **EMP400** Series.



Dimensions Unit = mm (in.)

DXF B297

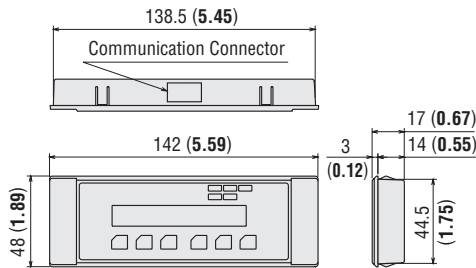

Panel Cut-Out

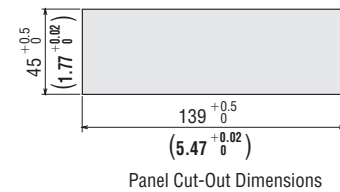

Communication Cable **FC04W5** (RoHS)

This is a 5 m (16.4 ft.) cable with a D-sub 9 connector at one end for the RS-232C communications between the PC and the **EMP400** Series controller.



Connector – Terminal Block Conversion Unit **CC50T1** (RoHS)

The **EMP400** Series and programmable controller can be connected via a terminal block. Cable Length: 1 m (3.3 ft.)

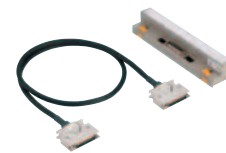

Dimensions Unit = mm (in.)

DXF B439

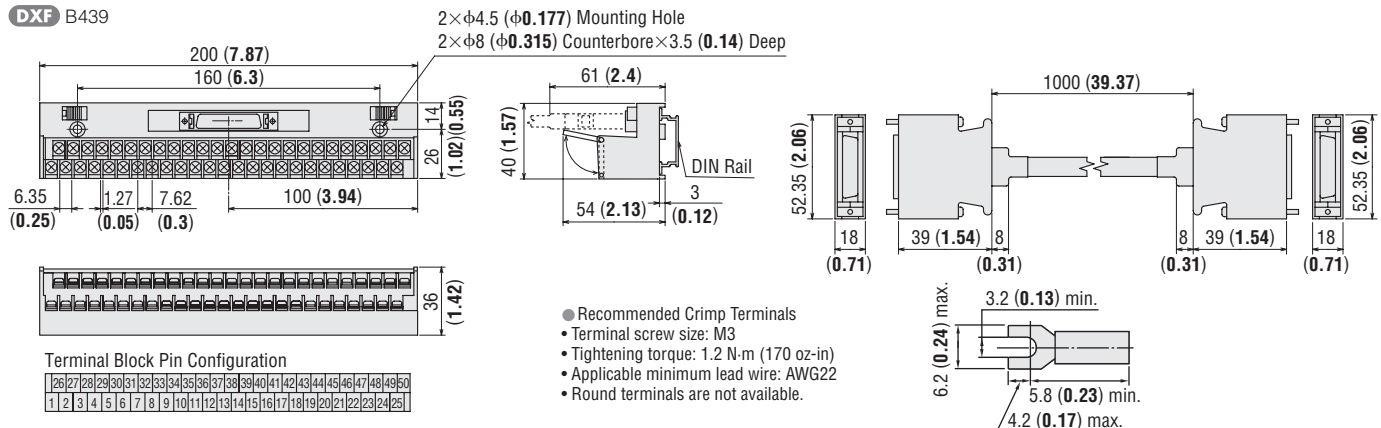

Introduction	AC Input Motor & Driver		DC Input Motor & Driver		Motor Only				Controllers	Accessories				
	0.36° / Geared / <i>AR</i>	0.72° / Geared / <i>AS</i>	0.36° / Geared / <i>AR</i>	0.36° / Geared / <i>ASX</i>	0.36° / Geared / <i>CRK</i>	0.36° / Geared / <i>CMK</i>	0.9° / 1.8° / Geared / <i>RBK</i>	0.36° / <i>PK</i>	0.72° / <i>PK</i>	0.9° / <i>PK</i>	1.8° / <i>PK/PV</i>	Geared / <i>PK</i>	<i>SCX10</i> <i>EMP400</i> <i>/5G8030J</i>	