

The **BHF** Series consists of a high-power 200 W (1/4 HP) AC motor combined with a dedicated speed controller using inverter technology. Each motor comes pre-assembled with a gearhead.

The combined speed controller has been selected to match the motor specification, so superior speed control can be performed easily. The electromagnetic brake type is also available to provide a perfect unit for vertical drive applications.

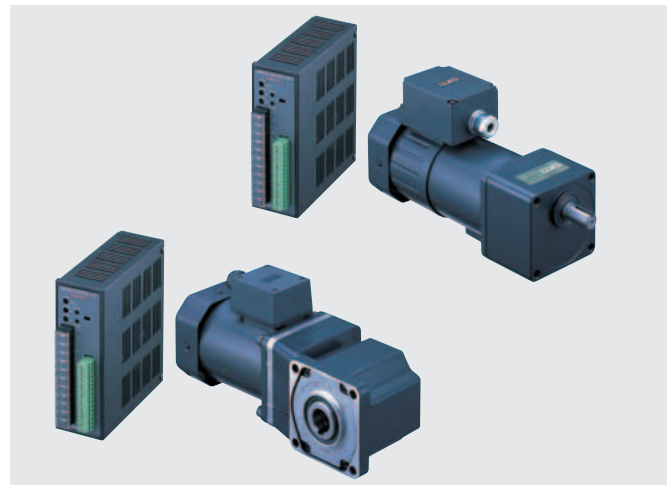

● For detailed product safety standard information including standards, file number and certification body, please visit www.orientalmotor.com.



■ Features

● Excellent speed stability

The combination of a dedicated speed controller with a motor achieves excellent speed stability with a fluctuation of only $\pm 3\%$. The speed controller is already optimized for use with the motor, so detail adjustments are not required to achieve accurate speed control.

● Speed Control during Vertical Drive

The motor with an electromagnetic brake enables stable speed control even during vertical drive (gravitational operation). The electromagnetic brake is automatically controlled by the speed controller.

Note

● Regeneration energy generates during vertical drive. Be sure to use a regeneration unit (sold separately).

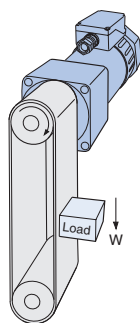

● Automatic control of an electromagnetic brake

The AC speed control system with an electromagnetic brake allows automatic on/off control of the electromagnetic brake (power off activated type) on the speed controller side. There is no need to supply a separate power supply or program a control sequence.

● Smallest frame size among 200 W (1/4 HP) motors

The **BHF** Series achieves an output of 200 W (1/4 HP) the highest among Oriental Motor's standard AC motors, with the smallest frame size [104 mm (4.09 in.) square] in that class. This allows for a reduction in the size of your equipment.

● Wiring length of up to 50 m (164 ft.)

The wiring distance between the motor and speed controller can be extended to a maximum of 50 m (164 ft.). (A motor cable is not supplied with the product. Please provide the appropriate cable.)

● Full-range functionality

The **BHF** Series offers a variety of functions such as alarm output, speed monitor output and individual acceleration/deceleration setting. The speed controller also has a built-in I/O power supply.

● Wide product variations

Pre-assembled gearmotors are available in a right-angle shaft type equipped with a hypoid gear (hollow shaft, solid shaft) and a parallel shaft type. A wide range of gear ratios are available. An electromagnetic brake type is also available.

● Global specifications

The **BHF** Series conforms to international power-supply voltage specifications, including single-phase 100-115 VAC, single-phase 200-230 VAC and three-phase 200-230 VAC. All units comply with the UL/CSA standards and bear the CE mark as proof of compliance with the Low Voltage Directive and EMC Directive.

System Configuration

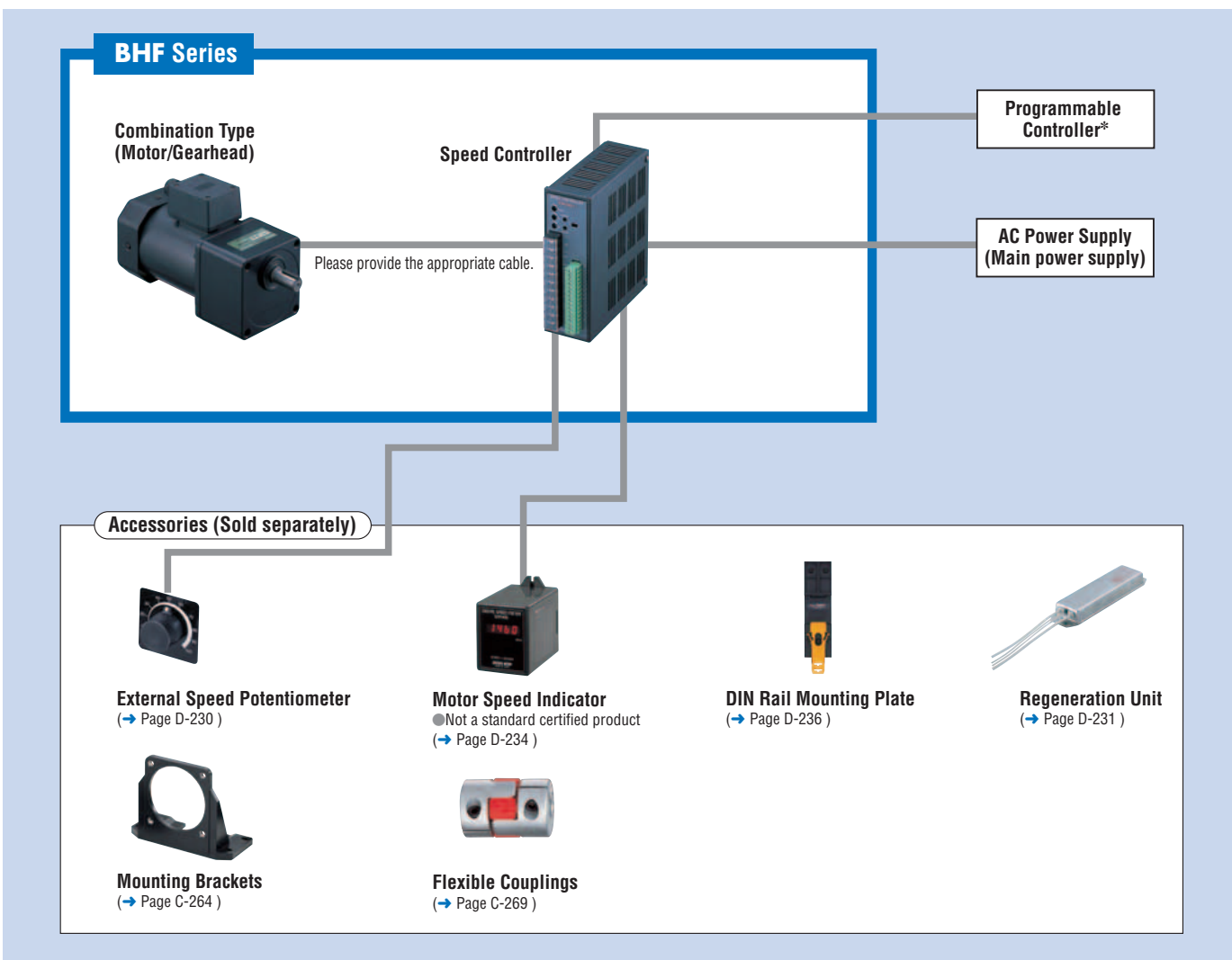

Examples of System Configuration

BHF Series Combination Type - Parallel Shaft BHF62AT-30	+	Sold Separately				
		External Speed Potentiometer	Motor Speed Indicator	DIN Rail Mounting Plate	Mounting Bracket	Flexible Coupling
		PAVR-20KZ	SDM496	PADP01	SOL6M8	MCL5518F12

● The system configuration shown above is an example. Other combinations are available.

* Not supplied

Product Number Code

BHF 6 2 A M T - 100 RH

① ② ③ ④ ⑤ ⑥ ⑦ ⑧

①	Series	BHF: BHF Series
②	Motor Frame Size	6: 104 mm (4.09 in.)
③	Output Power (W)	2: 200 W (1/4 HP)
④	Power Supply Voltage	A: Single-Phase 100-115 VAC C: Single-Phase 200-230 VAC S: Three-Phase 200-230 VAC
⑤	Blank: Without Electromagnetic Brake M: With Electromagnetic Brake	
⑥	T: Terminal Box Type	
⑦	Gear Ratio, Motor Shaft Type	Number: Gear Ratio of Combination Type A: Round Shaft Type
⑧	Type of Gearhead (Combination type only)	Blank: Parallel Shaft Type RH: Right-Angle, Hollow Shaft Type RA: Right-Angle, Solid Shaft Type

Product Line

Combination Type The combination type comes with the motor and its dedicated gearhead pre-assembled which simplifies installation in equipment. Motors and gearheads are also available separately to facilitate changes or repairs.

Speed Control Motor and Controller Package (RoHS)

◇ Combination Type

Type	Power Supply Voltage	Model	Gear Ratio
Combination Type with Right-Angle Hollow Shaft	Single-Phase 100-115 VAC	BHF62AT-□RH	5, 9, 15, 30, 50, 100, 180
	Single-Phase 200-230 VAC	BHF62CT-□RH	5, 9, 15, 30, 50, 100, 180
	Three-Phase 200-230 VAC	BHF62ST-□RH	5, 9, 15, 30, 50, 100, 180
Combination Type with Right-Angle Solid Shaft	Single-Phase 100-115 VAC	BHF62AT-□RA	5, 9, 15, 30, 50, 100, 180
	Single-Phase 200-230 VAC	BHF62CT-□RA	5, 9, 15, 30, 50, 100, 180
	Three-Phase 200-230 VAC	BHF62ST-□RA	5, 9, 15, 30, 50, 100, 180
Combination Type with Parallel Shaft	Single-Phase 100-115 VAC	BHF62AT-□	3, 5, 9, 15, 30, 50, 100, 180
	Single-Phase 200-230 VAC	BHF62CT-□	3, 5, 9, 15, 30, 50, 100, 180
	Three-Phase 200-230 VAC	BHF62ST-□	3, 5, 9, 15, 30, 50, 100, 180

● Enter the gear ratio in the box (□) within the model name.

The following items are included in each product.
 Motor, Speed Controller, Gearhead, Mounting Brackets for Speed Controller (with screws), Mounting Screws*, Parallel Key, Operating Manual
 *For Combination Type with Parallel Shaft only

◇ Round Shaft Type

Power Supply Voltage	Model
Single-Phase 100-115 VAC	BHF62AT-A
Single-Phase 200-230 VAC	BHF62CT-A
Three-Phase 200-230 VAC	BHF62ST-A

The following items are included in each product.
 Motor, Speed Controller, Mounting Brackets for Speed Controller (with screws), Operating Manual

Speed Control Motor and Controller Package with Electromagnetic Brake (RoHS)

◇ Combination Type

Type	Power Supply Voltage	Model	Gear Ratio
Combination Type with Right-Angle Hollow Shaft	Single-Phase 100-115 VAC	BHF62AMT-□RH	5, 9, 15, 30, 50, 100, 180
	Single-Phase 200-230 VAC	BHF62CMT-□RH	5, 9, 15, 30, 50, 100, 180
	Three-Phase 200-230 VAC	BHF62SMT-□RH	5, 9, 15, 30, 50, 100, 180
Combination Type with Right-Angle Solid Shaft	Single-Phase 100-115 VAC	BHF62AMT-□RA	5, 9, 15, 30, 50, 100, 180
	Single-Phase 200-230 VAC	BHF62CMT-□RA	5, 9, 15, 30, 50, 100, 180
	Three-Phase 200-230 VAC	BHF62SMT-□RA	5, 9, 15, 30, 50, 100, 180
Combination Type with Parallel Shaft	Single-Phase 100-115 VAC	BHF62AMT-□	3, 5, 9, 15, 30, 50, 100, 180
	Single-Phase 200-230 VAC	BHF62CMT-□	3, 5, 9, 15, 30, 50, 100, 180
	Three-Phase 200-230 VAC	BHF62SMT-□	3, 5, 9, 15, 30, 50, 100, 180

● Enter the gear ratio in the box (□) within the model name.

The following items are included in each product.
 Motor, Speed Controller, Gearhead, Mounting Brackets for Speed Controller (with screws), Mounting Screws*, Parallel Key, Operating Manual
 *For Combination Type with Parallel Shaft only

◇ Round Shaft Type

Power Supply Voltage	Model
Single-Phase 100-115 VAC	BHF62AMT-A
Single-Phase 200-230 VAC	BHF62CMT-A
Three-Phase 200-230 VAC	BHF62SMT-A

The following items are included in each product.
 Motor, Speed Controller, Mounting Brackets for Speed Controller (with screws), Operating Manual

Specifications

Speed Control Motor and Controller Package (RoHS)



Model	Combination Type with Right-Angle Hollow Shaft	BHF62AT-□RH	BHF62CT-□RH	BHF62ST-□RH	
	Combination Type with Right-Angle Solid Shaft	BHF62AT-□RA	BHF62CT-□RA	BHF62ST-□RA	
	Combination Type with Parallel Shaft	BHF62AT-□	BHF62CT-□	BHF62ST-□	
	Round Shaft Type	BHF62AT-A	BHF62CT-A	BHF62ST-A	
Rated Output Power	W (HP)	200 (1/4)			
Power Source	Voltage	VAC	Single-Phase 100-115 ±10%	Single-Phase 200-230 ±10%	Three-Phase 200-230 ±10%
	Frequency	Hz	50/60		
	Rated Input Current	A	5.4	3.1	1.75
	Maximum Input Current	A	8.3	4.9	2.7
Rated Speed	r/min	1500			
Rated Torque	N·m (oz·in)	1.27 (180)			
Starting Torque	N·m (oz·in)	1.27 (180)			
Permissible Torque	N·m (oz·in)	100~1500 r/min: 1.27 (180), 1800 r/min: 1.07 (151), 2400 r/min: 0.6 (85)			
Round Shaft Type					
Permissible Load Inertia J	×10 ⁻⁴ kg·m ² (oz·in ²)	8 (44)			
Speed Control Range	r/min	100~2400			
Speed Regulation	Load	±3% max. (0~Rated torque, at 1500 r/min)			
	Voltage	±3% max. (Power supply voltage ±10% at 1500 r/min with no load)			
	Temperature	±3% max. [0~+50°C (+32~+122°F) at 1500 r/min with no load]			

- The values for each specification apply to the motor only.
- Contains a built-in thermal protector (automatic return type).

Speed Control Motor and Controller Package with Electromagnetic Brake (RoHS)



Model	Combination Type with Right-Angle Hollow Shaft	BHF62AMT-□RH	BHF62CMT-□RH	BHF62SMT-□RH	
	Combination Type with Right-Angle Solid Shaft	BHF62AMT-□RA	BHF62CMT-□RA	BHF62SMT-□RA	
	Combination Type with Parallel Shaft	BHF62AMT-□	BHF62CMT-□	BHF62SMT-□	
	Round Shaft Type	BHF62AMT-A	BHF62CMT-A	BHF62SMT-A	
Rated Output Power	W (HP)	200 (1/4)			
Power Source	Voltage	VAC	Single-Phase 100-115 ±10%	Single-Phase 200-230 ±10%	Three-Phase 200-230 ±10%
	Frequency	Hz	50/60		
	Rated Input Current	A	5.4	3.1	1.75
	Maximum Input Current	A	8.3	4.9	2.7
Rated Speed	r/min	1500			
Rated Torque	N·m (oz·in)	1.27 (180)			
Starting Torque	N·m (oz·in)	1.27 (180)			
Permissible Torque	N·m (oz·in)	100~1500 r/min: 1.27 (180), 1800 r/min: 1.07 (151), 2400 r/min: 0.6 (85)			
Round Shaft Type					
Permissible Load Inertia J	×10 ⁻⁴ kg·m ² (oz·in ²)	8 (44)			
Speed Control Range	r/min	100~2400			
Speed Regulation	Load	±3% max. (0~Rated torque, at 1500 r/min)			
	Voltage	±3% max. (Power supply voltage ±10% at 1500 r/min with no load)			
	Temperature	±3% max. [0~+50°C (+32~+122°F) at 1500 r/min with no load]			
Electromagnetic Brake					
Static Friction Torque	N·m (oz·in)	1.5 (210)			
Gravitational Operation		Connect a regeneration unit [Accessories (Sold separately)], max. output 100 W (1/8 HP) (5 minutes rating)			

- The values for each specification apply to the motor only.
- Contains a built-in thermal protector (automatic return type).

● Enter the gear ratio in the box (□) within the model name.

Common Specifications

Item	Specifications
Acceleration/Deceleration Time	0.1~25 seconds (at 1000 r/min)
Speed Setting Methods	Select one of the following methods: · Set using the internal speed potentiometer · Set using an accessory external speed potentiometer: PAVR-20KZ (20 kΩ, 1/4 W) (Sold separately) · Set using external DC voltage: 0~5 VDC
Input Signals	Photocoupler input Input resistance 2.3 kΩ Operates at 12 VDC Common to CW/CCW, Speed setting mode selection, Slow down, Alarm reset
Output Signals	Open-collector output External use conditions 26.4 VDC, 10 mA max. Common to SPEED OUT (12P/R), ALARM OUT
Protective Functions	When the following are activated, the alarm signal output will be OFF and the ALARM LED will blink, then the motor will coast to a stop. · Overload protection: Activated when the motor load exceeds rated torque for a minimum of 5 seconds. · Overvoltage protection: Activated when gravitational operation is performed or a load exceeding the permissible load inertia is driven. Activated when the voltage applied to the speed controller exceeds 115 VAC or 230 VAC by a minimum of approximately 30%. · Overcurrent protection: Activated when an excessive current flows through the speed controller. · Undervoltage protection: Activated when the voltage applied to the speed controller falls below 100 VAC or 200 VAC by a minimum of approximately 15%. · Circuit overheat protection: Activated when the elements temperature of the speed controller exceeds its standard level. · Motor disconnection protection: Activated when the motor cable is improper connected or disconnected. · EEPROM error: Activated when error was detected in EEPROM.
Maximum Cable Extension Distance	Motor/Speed Controller Distance: 50 m (163.9 ft.)
Time Rating	Continuous

General Specifications

Item	Motor	Speed Controller
Insulation Resistance	100 MΩ or more when 500 VDC megger is applied between the windings and the case after rated operation under normal ambient temperature and humidity.	100 MΩ or more when 500 VDC megger is applied between the power supply input terminal and the protective earth terminal and between the power supply input terminal and the I/O terminal after continuous operation under normal ambient temperature and humidity.
Dielectric Strength	Sufficient to withstand 1.5 kVAC at 50 Hz and 60 Hz applied between the windings and the case for 1 minute after rated operation under normal ambient temperature and humidity.	Sufficient to withstand 1.5 kVAC at 50 Hz and 60 Hz applied between the power supply input terminal and the protective earth terminal for 1 minute, and 3 kVAC at 50 Hz and 60 Hz applied between the power supply input terminal and the I/O terminal for 1 minute after continuous operation under normal ambient temperature and humidity.
Temperature Rise	Temperature rise of windings is 70°C (126°F) or less measured by resistance change method after rated operation under normal ambient temperature and humidity with connecting a gearhead or equivalent heat radiation plate*.	—
Ambient Temperature	−10~+40°C (+14~+104°F) −10~+50°C (+14~+122°F) for 100/200 VAC (non-freezing)	0~+50°C (+32~+122°F) (non-freezing)
Ambient Humidity	85% or less (non-condensing)	85% or less (non-condensing)
Thermal Class	130 (B)	—
Degree of Protection	IP54 (excluding the motor-installation surface of the round shaft type)	IP10

*Size of heat radiation plate (material: aluminum): 230 × 230 mm (9.06 × 9.06 in.), 5 mm (0.20 in.) thick

Gearmotor – Torque Table of Combination Type

Right-Angle Shaft

Unit = N·m (lb-in)

Model	Gear Ratio	5	9	15	30	50	100	180
		Motor Speed	100 r/min	20	11	6.7	3.3	2
BHF62AT-□RH/RA, BHF62AMT-□RH/RA BHF62CT-□RH/RA, BHF62CMT-□RH/RA BHF62ST-□RH/RA, BHF62SMT-□RH/RA	1500 r/min	300	167	100	50	30	15	8.3
	1800 r/min	360	200	120	60	36	18	10
	2400 r/min	480	267	160	80	48	24	13
BHF62AT-□RH/RA, BHF62AMT-□RH/RA BHF62CT-□RH/RA, BHF62CMT-□RH/RA BHF62ST-□RH/RA, BHF62SMT-□RH/RA	100~1500 r/min	4.6 (40)	8.3 (73)	13.9 (123)	27.8 (240)	40.0 (350)	54.5 (480)	60 (530)
	1800 r/min	3.9 (34)	7.0 (61)	11.7 (103)	23.4 (200)	37.0 (320)	50.5 (440)	60 (530)
	2400 r/min	2.2 (19.4)	3.9 (34)	6.6 (58)	13.1 (115)	21.9 (193)	43.8 (380)	56.0 (490)

● Enter the gear ratio in the box (□) within the model name.

● Rotation direction of the motor and that of the gear output shaft are the opposite.

● Parallel Shaft

Unit = N·m (lb-in)

Model	Gear Ratio	3	5	9	15	30	50	100	180
		100 r/min	33	20	11	6.7	3.3	2	1
Motor Speed	1500 r/min	500	300	167	100	50	30	15	8.3
	1800 r/min	600	360	200	120	60	36	18	10
	2400 r/min	800	480	267	160	80	48	24	13
BHF62AT -□, BHF62AMT -□	100~1500 r/min	3.4 (30)	5.7 (50)	10.3 (91)	16.4 (145)	32.8 (290)	40 (350)	40 (350)	40 (350)
BHF62CT -□, BHF62CMT -□	1800 r/min	2.9 (25)	4.8 (42)	8.7 (76)	13.8 (122)	27.6 (240)	40 (350)	40 (350)	40 (350)
BHF62ST -□, BHF62SMT -□	2400 r/min	1.6 (14.1)	2.7 (23)	4.9 (43)	7.7 (68)	15.5 (137)	24.3 (210)	40 (350)	40 (350)

● A colored background (□) indicates gearhead output shaft rotates in the same direction as the motor, while the others rotates in the opposite direction.

■ Permissible Load Inertia J of Combination Type

Unit = $\times 10^{-4}$ kg·m²(oz-in²)

Model	Gear Ratio	3	5	9	15	30	50	100	180
BHF62 □ T -□ RH , -□ RA BHF62 □ MT -□ RH , -□ RA	—	—	50 (270)	162 (880)	450 (2400)	1800 (9800)	5000 (27000)	5000 (27000)	5000 (27000)
BHF62 □ T -□ BHF62 □ MT -□	18 (98)	18 (98)	—	—	—	—	—	—	—

■ Permissible Overhung Load and Permissible Thrust Load

Model	Gear Ratio	Permissible Overhung Load*				Permissible Thrust Load	
		10 mm (0.39 in.) from shaft end		20 mm (0.79 in.) from shaft end		N	lb.
		N	lb.	N	lb.		
BHF62 □ T -□ RH BHF62 □ MT -□ RH	5~30 50~180	1200* 2200*	270* 490*	1100* 2000*	240* 450*	300	67
BHF62 □ T -□ RA BHF62 □ MT -□ RA	5~30 50~180	900 1700	200 380	1000 1850	220 410	300	67
BHF62 □ T -□ BHF62 □ MT -□	3~30 50~180	550 650	123 146	800 1000	180 220	200	45

*With the hollow shaft type, the permissible overhung load is measured from the flange-mounting surface.

● Permissible overhung load and thrust load for round shaft type → Page C-17

■ Speed – Torque Characteristics

The characteristics shown to the right are applicable for the motors only.

Continuous Duty Region: Continuous operation is possible in this region.

Common to all **BHF** Models

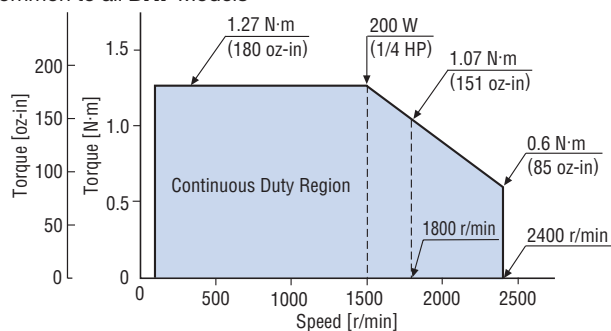

● Enter the power supply voltage (**A**, **C** or **S**) in the box (□).
Enter the gear ratio in the box (□) within the model name.

Vertical Drive (Gravitational Operation)

The **BHF** Series provides stable speed control during gravitational operation.

During vertical drive shown in the figure below, normally an external force causes the motor to rotate and function as a power generator. If this energy is applied to the speed controller, an error will occur. A regeneration unit (sold separately) can convert regenerative energy into thermal energy for dissipation. Use the accessory regeneration unit **EPRC-400P** when using the motor for vertical drive applications or when braking a large inertial load quickly.

Regenerative power: 100 W (1/8 HP) (5-minute rating)
 Instantaneous regenerative power: 300 W (1/2.5 HP)

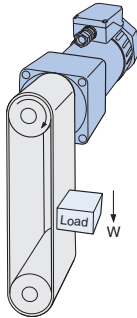

Regenerative Power

The regenerative power can be estimated using the formula below. Use the calculated value as a guideline.

$$\text{Regenerative Power (W)} = 0.1047 \times T_L \text{ [N}\cdot\text{m]} \times N \text{ [r/min]}$$

T_L : Load torque N : Speed

● Use the electromagnetic brake type for gravitational operation.

Gravitational Operation Capability

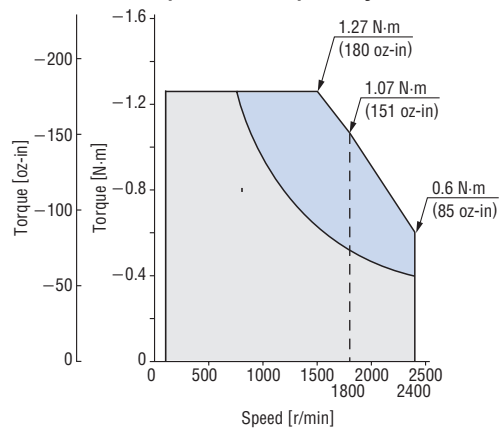

Use the time shown below as a guideline when performing continuous gravitational operation:

□: Operating range in which regenerative power is 100 W (1/8 HP) or less
 Allowable time for continuous gravitational operation: 1 minute, 30% ED*

■: Operating range in which regenerative power exceeds 100 W (1/8 HP)
 Allowable time for continuous gravitational operation: 1 minute, 20% ED*
 * 30% ED and 20% ED indicate the percentage of the time of gravitational operation and stopping time.

Example: 1 minute, 30% =
 Under gravitational operation: 1 minute
 Stop: 2 minutes 20 seconds

Mounting Method for Right-Angle, Hollow Shaft Types

→ Page C-237

Dimensions Unit = mm (in.)

● Mounting screws are included with the combination type parallel shaft. Dimensions for mounting screws → Page C-281

● Speed Control Motor and Controller Package

◇ Combination Type with Right-Angle Hollow Shaft

BHF62AT-□RH, BHF62CT-□RH, BHF62ST-□RH

Motor: BHM62T-G2

Gearhead: BH6G2-□RH

Mass: 10.0 kg (22 lb.) (Including gearhead)

DXF A301

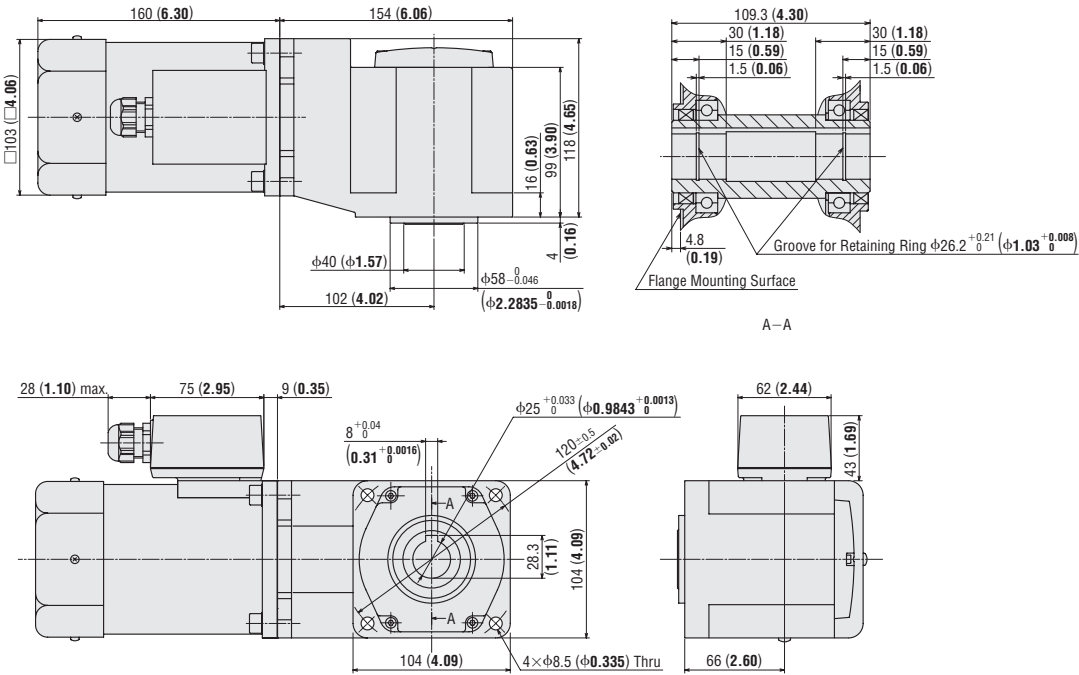

● Use cable with a diameter of $\phi 6 \sim \phi 12$ mm ($\phi 0.24 \sim \phi 0.47$ in.).

● Details of terminal box → Page C-283

◇ Key (Included)

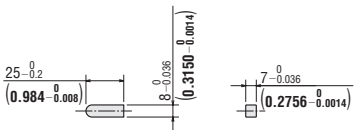

● Enter the gear ratio in the box (□) within the model name.

Introduction
BX
B1F
AC Input
B1E
BLU
BLH
DC Input
B1V
BHF
AC Speed Control Motors
FE100/ FE200
ES01/ ES02
US
Accessories
Installation

◇ Combination Type with Right-Angle Solid Shaft

BHF62AT-□RA, BHF62CT-□RA, BHF62ST-□RA

Motor: BHM62T-G2

Gearhead: BH6G2-□RA

Mass: 10.0 kg (22 lb.) (Including gearhead)

DXF A302

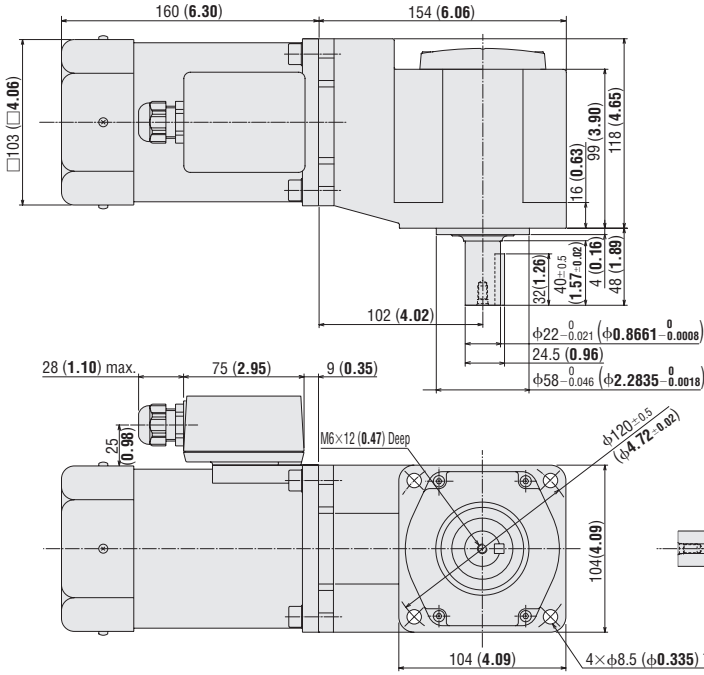

◇ Key and Key Slot (Included)

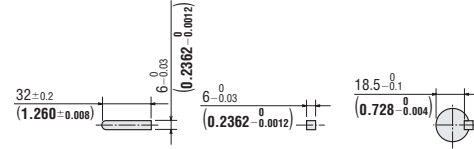

● At the time of shipment, a key is inserted on the gearhead's shaft.

- Use cable with a diameter of $\phi 6 \sim \phi 12$ mm ($\phi 0.24 \sim \phi 0.47$ in.).
- Details of terminal box → Page C-283

◇ Combination Type with Parallel Shaft

BHF62AT-□, BHF62CT-□, BHF62ST-□

Motor: BHM62T-G2

Gearhead: BH6G2-□

Mass: 8.0 kg (17.6 lb.) (Including gearhead)

DXF A304

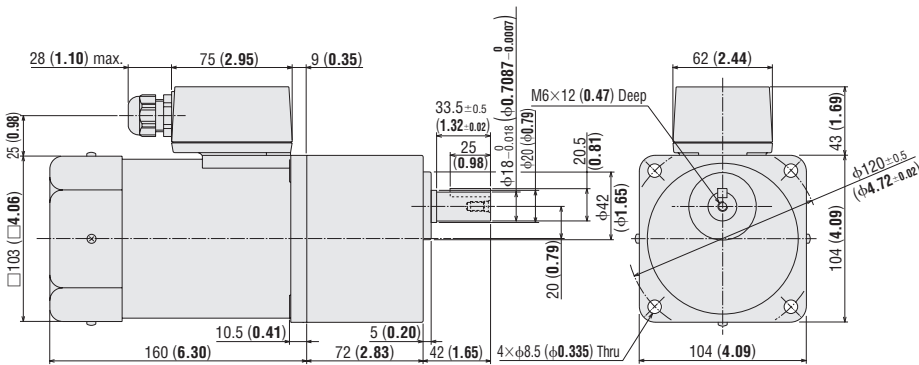

- Use cable with a diameter of $\phi 6 \sim \phi 12$ mm ($\phi 0.24 \sim \phi 0.47$ in.).
- Details of terminal box → Page C-283

◇ Key and Key Slot (Included)

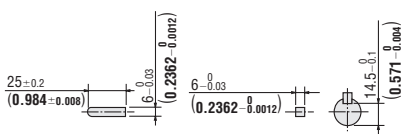

● At the time of shipment, a key is inserted on the gearhead's shaft.

● Enter the gear ratio in the box (□) within the model name.

◇ Round Shaft Type

BHF62AT-A, BHF62CT-A, BHF62ST-A

Motor: BHM62T-A

Mass: 5.0 kg (11 lb.)

DXF A308

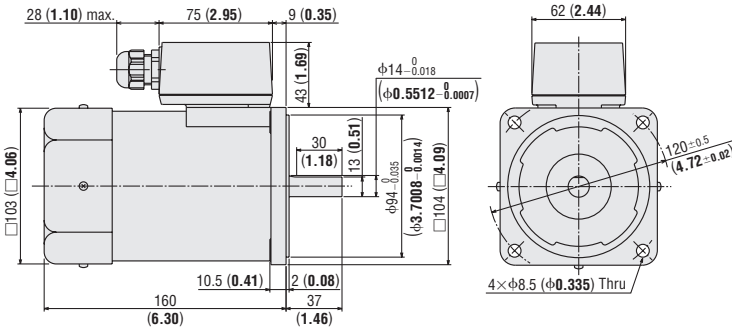

- Use cable with a diameter of $\phi 6 \sim \phi 12$ mm ($\phi 0.24 \sim \phi 0.47$ in.).
- Details of terminal box → Page C-283

● Speed Control Motor and Controller Package with Electromagnetic Brake

◇ Combination Type with Right-Angle Hollow Shaft

BHF62AMT-□RH, BHF62CMT-□RH, BHF62SMT-□RH

Motor: BHM62MT-G2

Gearhead: BH6G2-□RH

Mass: 11.5 kg (25.3 lb.) (Including gearhead)

DXF A384

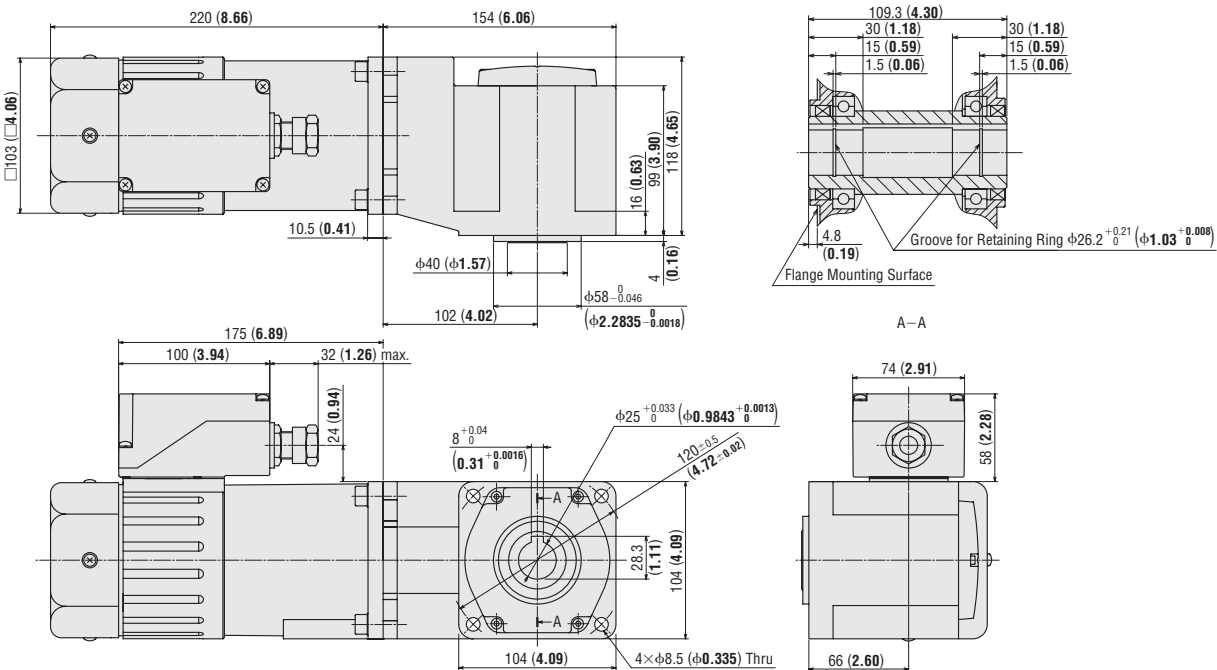

- Use cable with a diameter of $\phi 8 \sim \phi 12$ mm ($\phi 0.31 \sim \phi 0.47$ in.).
- Details of terminal box → Page C-283

◇ Key (Included)

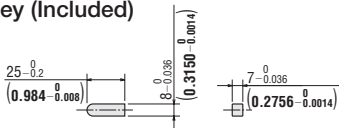

- Enter the gear ratio in the box (□) within the model name.

◇ Combination Type with Right-Angle Solid Shaft

BHF62AMT-□RA, BHF62CMT-□RA, BHF62SMT-□RA

Motor: BHM62MT-G2

Gearhead: BH6G2-□RA

Mass: 11.5 kg (25.3 lb.) (Including gearhead)

DXF A385

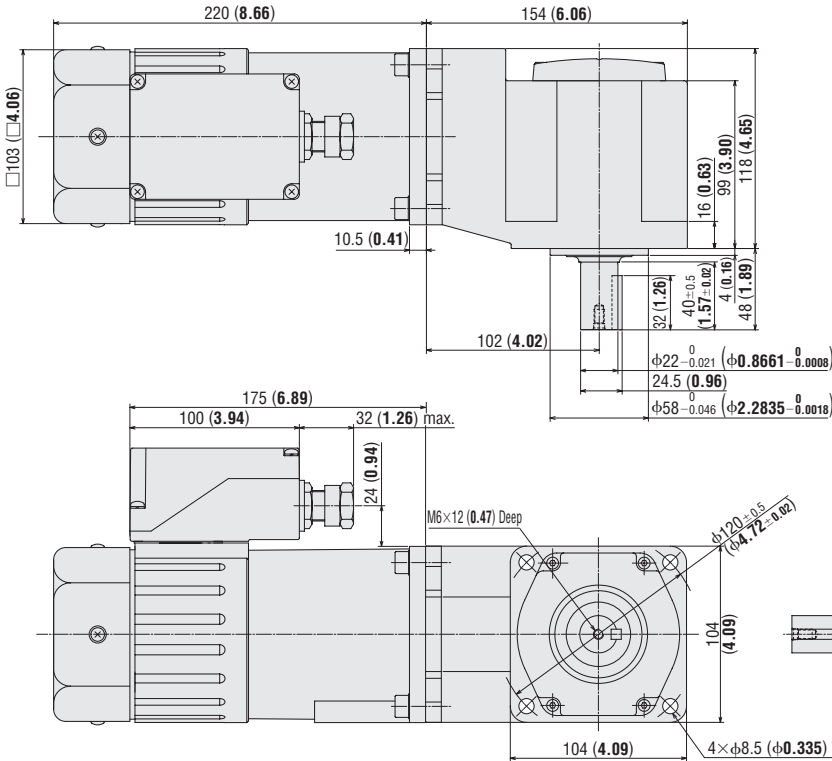

- Use cable with a diameter of $\phi 8 \sim \phi 12$ mm ($\phi 0.31 \sim \phi 0.47$ in.).
- Details of terminal box → Page C-283

◇ Key and Key Slot (Included)

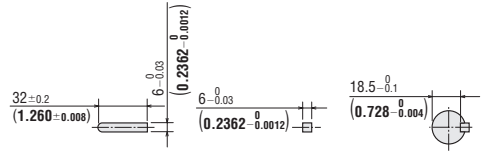

- At the time of shipment, a key is inserted on the gearhead's shaft.

◇ Combination Type with Parallel Shaft

BHF62AMT-□, BHF62CMT-□, BHF62SMT-□

Motor: BHM62MT-G2

Gearhead: BH6G2-□

Mass: 9.5 kg (20.9 lb.) (Including gearhead)

DXF A386

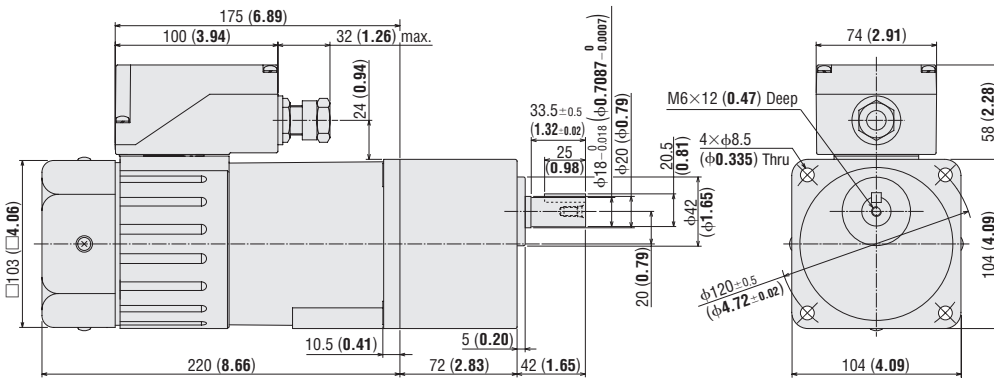

- Use cable with a diameter of $\phi 8 \sim \phi 12$ mm ($\phi 0.31 \sim \phi 0.47$ in.).
- Details of terminal box → Page C-283

◇ Key and Key Slot (Included)

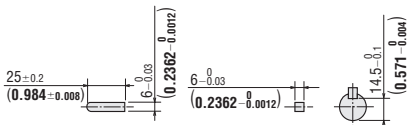

- At the time of shipment, a key is inserted on the gearhead's shaft.

- Enter the gear ratio in the box (□) within the model name.

◇ Round Shaft Type

BHF62AMT-A, BHF62CMT-A, BHF62SMT-A

Motor: BHM62MT-A

Mass: 6.5 kg (14.3 lb.)

DXF A387

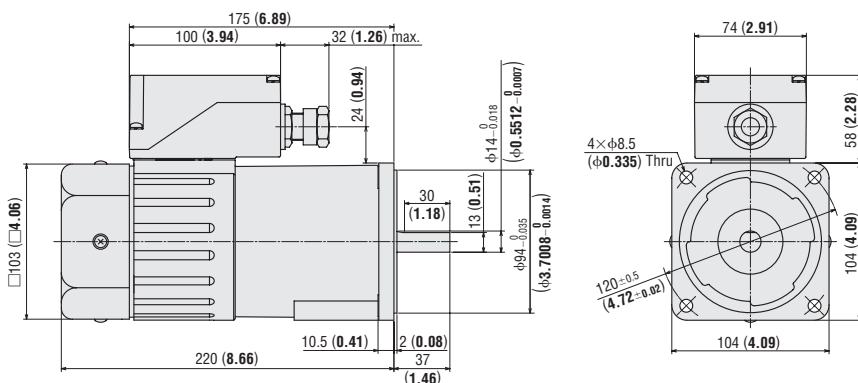

- Use cable with a diameter of $\phi 8 \sim \phi 12$ mm ($\phi 0.31 \sim \phi 0.47$ in.).
- Details of terminal box → Page C-283

◇ Speed Controller

FSP200-1, FSP200-2, FSP200-3

Mass: 0.6 kg (1.32 lb.)

DXF A390

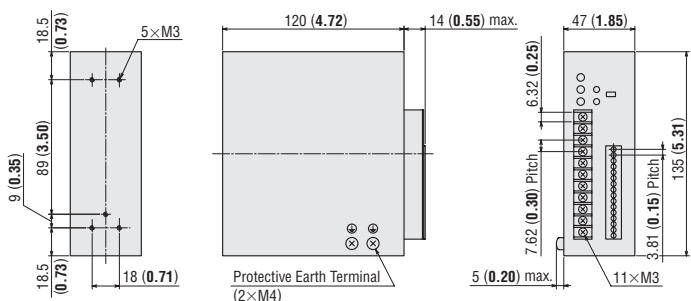

◇ Mounting Bracket for Speed Controller (2 pieces included)

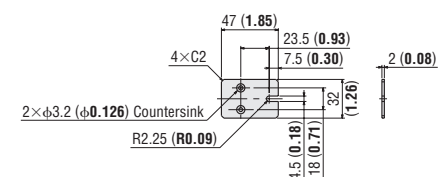

Connection and Operation

Names and Functions of Speed Controller Parts

Internal Potentiometer	
Display	Function
SPEED	Internal Speed Potentiometer
SS	Acceleration Time Potentiometer
SD	Deceleration Time Potentiometer

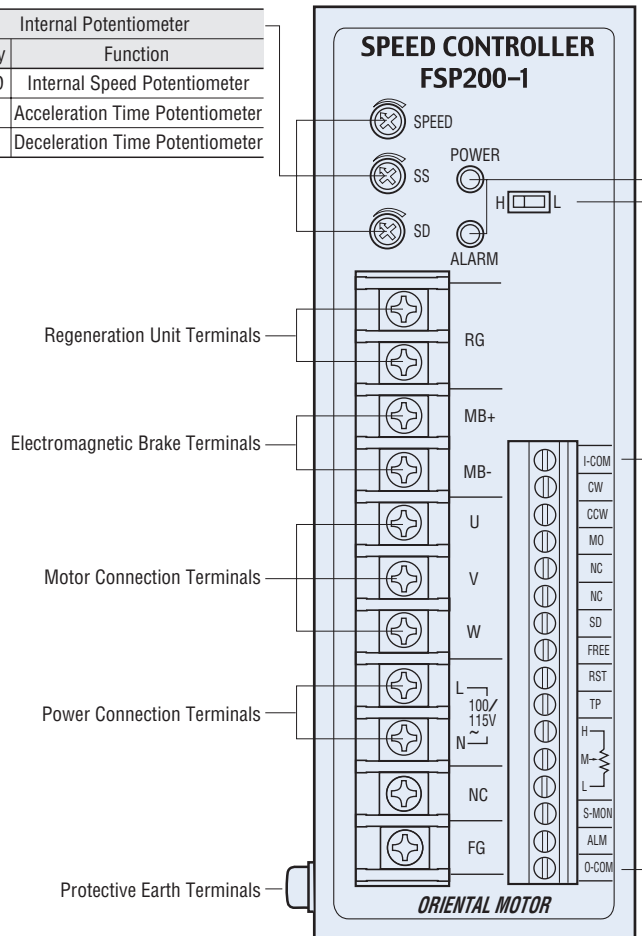

● The speed controller shown above uses a single-phase 100/115 VAC power supply input.

LED Display		
Display	Function	Lighting Condition
POWER	Power Indicator	Turns on (green) while power is being supplied.
ALARM	Alarm Indicator	Turns on (red) or blinks when protective function is activated.

Switch
Set the switch to "H" if the cable between the motor and speed controller is less than 10 m (32.8 ft.) in length. Set it to "L" if the cable length exceeds 10 m (32.8 ft.).

Input/Output Signal Terminals Block		
Display	Signal Name	Function
I-COM	Ground Terminal for Input Signals	Ground terminal for input signals
CW	Clockwise Direction Input	Clockwise direction/stop switching input signal
CCW	Counterclockwise Direction Input	Counterclockwise direction/stop switching input signal
MO	Speed Setting Switching Input	Internal/external speed setting switching input
NC	—	—
NC	—	—
SD	Slow Down Input	Instantaneous stop/deceleration stop switching input
FREE	Electromagnetic Brake Release Input	Electromagnetic brake releases/locks switching input
RST	Alarm Reset Input	This input functions as the Alarm-RESET input when the speed controller protective functions is activated.
TP	Thermal Signal Input	This input is used to connect the lead wire of the regeneration unit's internal thermal protector.
H, M, L	Speed Setting Input	These are connected for speed control by the external speed potentiometer or external DC voltage.
S-MON	Speed Monitor Output	This output is used to monitor the motor speed. Pulse signals at a rate of 12 pulses per rotation of the motor output shaft.
ALM	Alarm Output	When the protective function is activated, this output is set to OFF and the motor stops.
O-COM	Ground Terminal for Output Signals	Ground terminal for output signals

Brushless Motors/AC Speed Control Motors

● Connection Diagrams

◇ Single-phase 100-115 VAC,
Single-phase 200-230 VAC

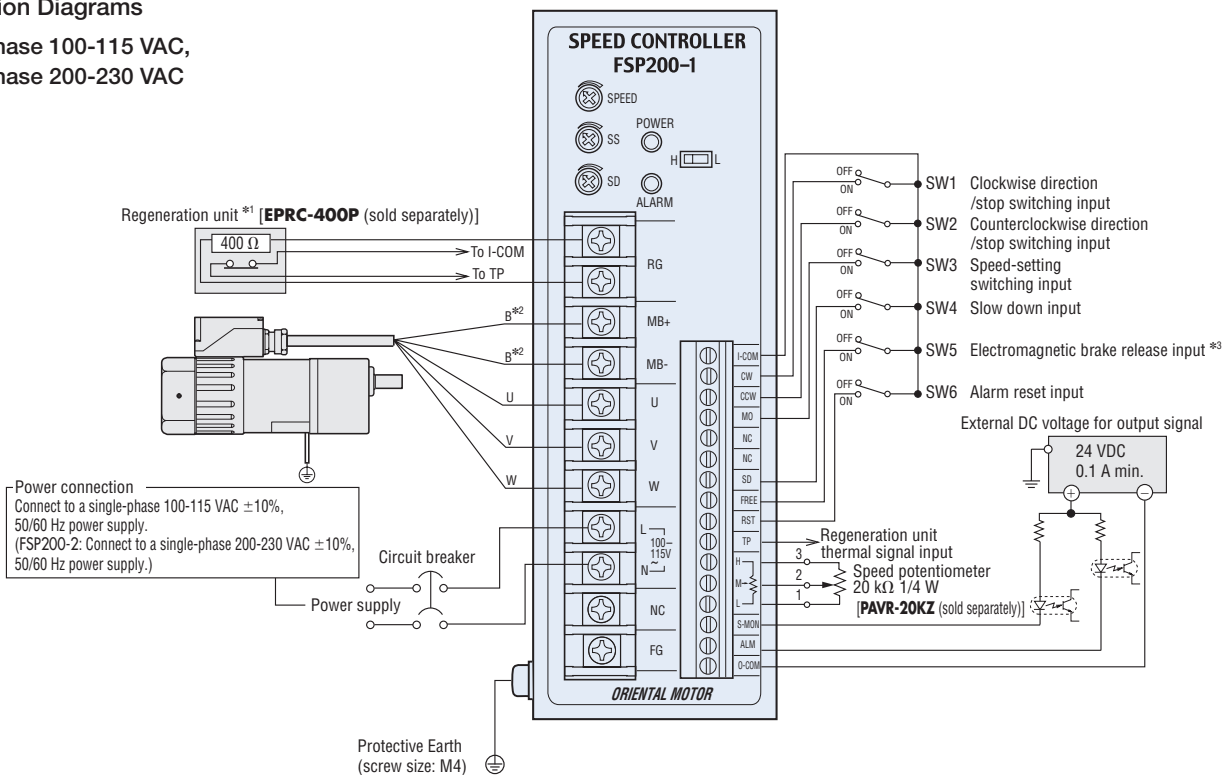

◇ Three-phase 200-230 VAC

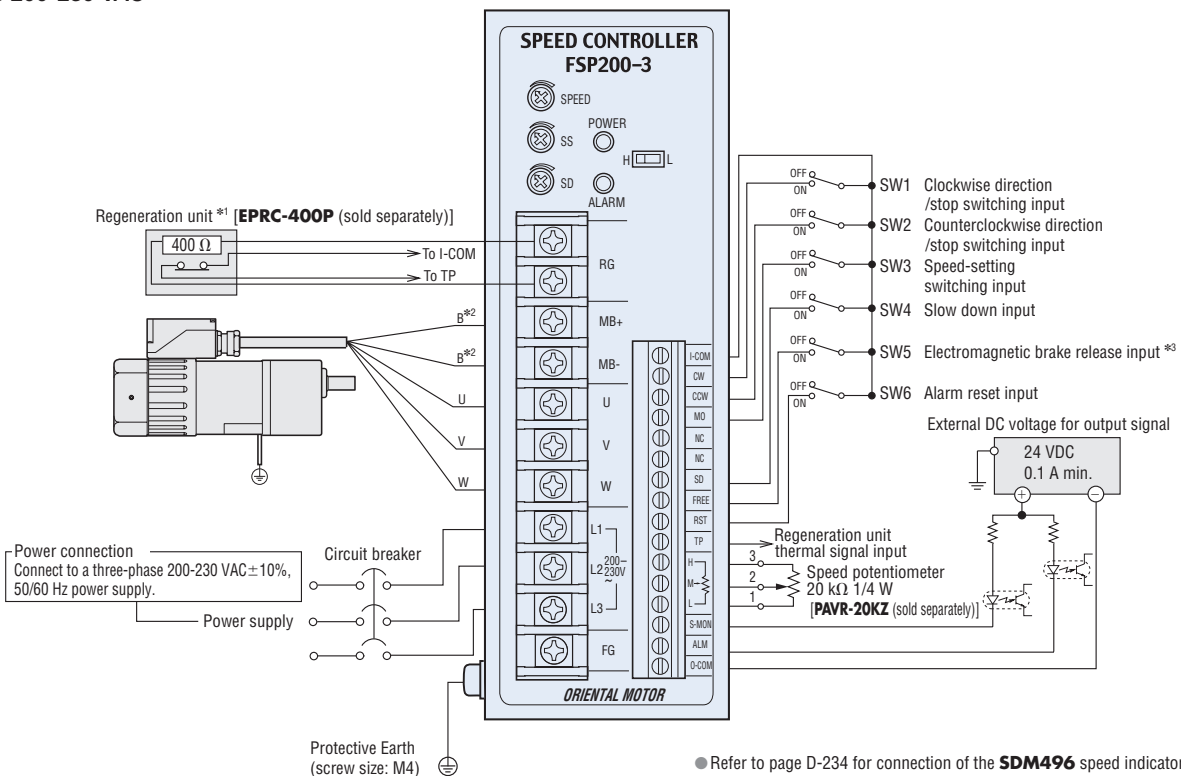

● Refer to page D-234 for connection of the **SDM496** speed indicator.

*1 This should be connected only when using a regeneration unit.

*2 This should be connected only for a speed control motor and controller package with electromagnetic brake.

*3 The electromagnetic brake release input can be used only with a speed control motor and controller package with electromagnetic brake.

Notes

- When wiring the motor and the speed controller, keep a maximum distance of 50 m (164 ft.) or less. If the wiring between the motor and the speed controller needs to be extended by 10 m (32.8 ft.) or more, use a polyethylene-insulated electric wire of AWG16 (1.25 mm²) or larger. Do not connect more than one cable or allow the overall wiring length to exceed 50 m (164 ft.). This may cause a malfunction.
- With the electromagnetic brake type, setting the wiring length too long delays the operation of the electromagnetic brake [by approx. 100 ms at a wiring length of 50 m (164 ft.)]. To minimize the delay time, use separate cables for the electromagnetic brake and motor cable.
- The signal wiring and motor cables should be kept away from noise-generating equipment or power lines.

◇Connecting the Motor and Speed Controller

A motor cable is not supplied with the product. Please purchase the appropriate cable.

●Connecting the Motor

[Applicable lead wires]

AWG18 (0.75 mm²) min.

[Applicable Crimp Terminals]

Use a crimp terminal for the electromagnetic brake type.

•Terminal Block

Round Terminal with Insulation

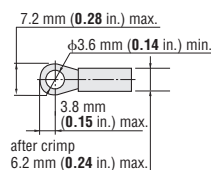

U-Shape Terminal with Insulation

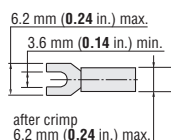

•Protective Earth Terminal

Round Terminal with Insulation

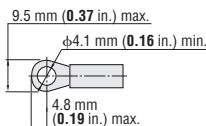

●Connecting the Speed Controller

[Applicable lead wires]

AWG18 (0.75 mm²) min.

[Applicable Crimp Terminals]

•Power Connection Terminal, Motor Connection Terminal

Round Terminal with Insulation

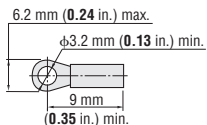

•Protective Earth Terminal

Round Terminal with Insulation

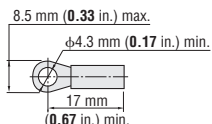

Input/Output Signal Terminals

When a crimp terminal is used for connection, use such terminals as shown below.

Manufacturer: Phoenix Contact

AI 0.25-6

Applicable wire size: AWG24 (0.2 mm²)

AI 0.34-6

Applicable wire size: AWG22 (0.3 mm²)

AI 0.5-6

Applicable wire size: AWG20 (0.5 mm²)

●Timing Chart

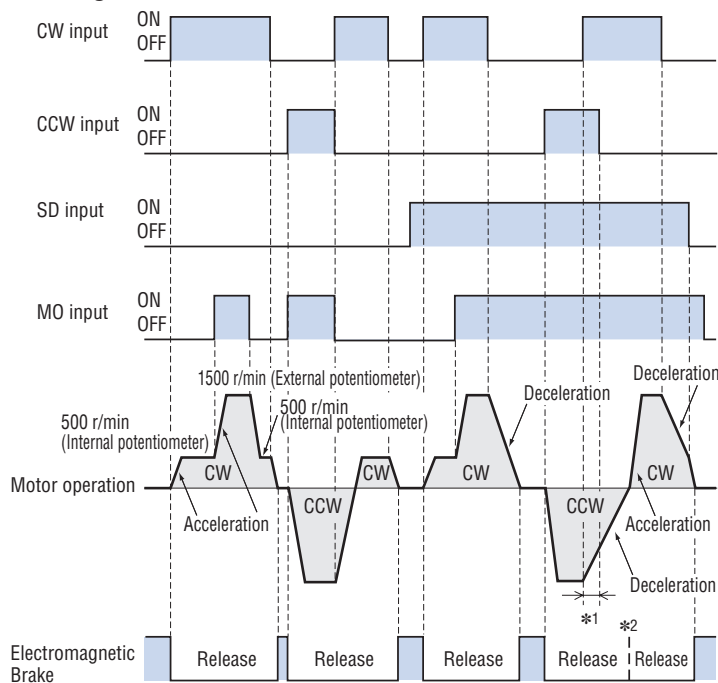

*1 The motor will stop if the CW and CCW inputs are simultaneously turned ON.

*2 The electromagnetic brake may be left released when the motor runs and/or stops if a short cycle or a shorter time is set for the acceleration/deceleration time.

- The CW input signal, CCW input signal, M0 input signal and SD input signal can be used to control all motor operations, such as run, stop, direction switching, speed switching.
- Switching the CW input ON will cause the motor to turn clockwise as viewed from the motor shaft, while switching the CCW input ON will cause the motor to turn counterclockwise. Switching each signal OFF will stop the motor. The motor will accelerate at the rise time corresponding to the time set on the acceleration time potentiometer.
- Switching the M0 input ON select the speed set on the external speed potentiometer. Switching the M0 input OFF will cause the motor to operate at the speed set on the internal speed potentiometer. The timing chart shown left is based on an internal speed potentiometer setting of 500 r/min and an external speed potentiometer setting of 1500 r/min.
- If the motor is stopped with switching the SD input ON, the motor stops at the time set by the deceleration time potentiometer.
- To release the electromagnetic brake when the motor is stopped, turn the FREE (electromagnetic brake release) input ON. This releases the electromagnetic brake and allow the motor's output shaft to turn freely. (This function is available only with a speed control system with an electromagnetic brake.)

Note

- Ensure that the temperature of the motor case does not exceed 90°C (194°F).

● Signal Input Circuit

◇ Input Signal Circuit

Common to CW, CCW and SD, FREE*, RST inputs.

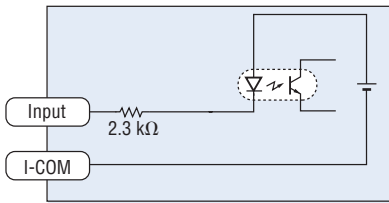

* The FREE input is used only with a speed control system with electromagnetic brake.

◇ Connection Example for Input Signals

● Controlled by Small Capacity Relays

Speed Controller

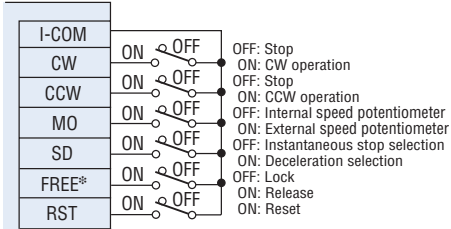

● Use a small capacity contact point type relay capable of switching 24 VDC, 5 mA.

* The FREE input is used only with a speed control system with electromagnetic brake.

● Electronic Input Control

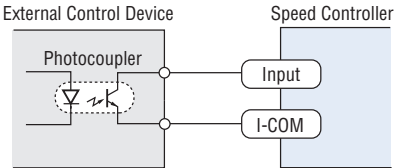

● Signal Output Circuit

◇ Output Signal Circuit

Common to S-MON, ALM outputs.

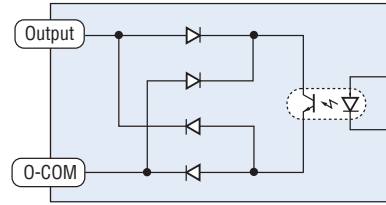

◇ Connection Example for Output Signals

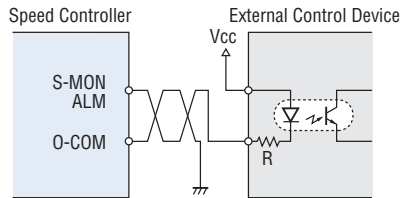

Output signal is open-collector output, so an external power supply (Vcc) is required. Use a power supply of no more than 26.4 VDC and connect a limit resistor (R) so that the output current does not exceed 10 mA. When using neither the speed output function nor the alarm output function, this connection is not required.

Speed monitor output: Pulse signals are output at a rate at

12 pulses per rotation of the motor output shaft. (When the pulse duty is 50%)

(Note that this is monitoring of the speed command issued from the speed controller to the motor, not that of the speed measured at the motor's output shaft.)

$$\text{Motor speed [r/min]} = \frac{\text{Speed output frequency [Hz]}}{12} \times 60$$

Alarm output: This signal is output when a protection function for overload, circuit overheat, overvoltage, undervoltage, overcurrent or EEPROM error has been activated. When an alarm signal is output, this output is turned to OFF between the ALM output and O-COM terminals.

● Speed Setting Method

◇ Speed Setting by Internal Speed Potentiometer

The internal speed potentiometer is selected when the M0 (speed-setting switching input) is set to OFF. Turning the internal speed potentiometer clockwise sets a faster speed, while turning it counterclockwise brings the motor to a stop.

◇ Speed Setting by External Speed Potentiometer (Sold separately)

The external speed potentiometer can be used when the M0 (speed-setting switching input) is set to ON. When the accessory external speed potentiometer is used, connect it as illustrated below. Turning the external speed potentiometer clockwise sets a faster speed.

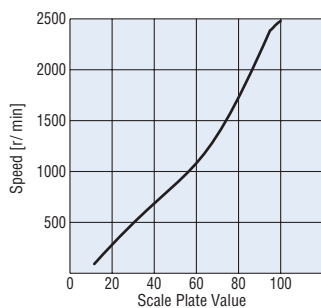
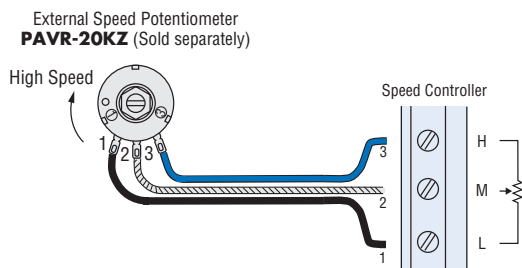

External Speed Potentiometer Scale - Speed Characteristics (Representative values)

◇ Speed Setting by External DC Voltage

External DC voltage can be used when the M0 (speed-setting switching input) is set to ON. To set the motor speed by external DC voltage, connect a DC power supply as illustrated below. Raising the DC voltage sets a faster speed.

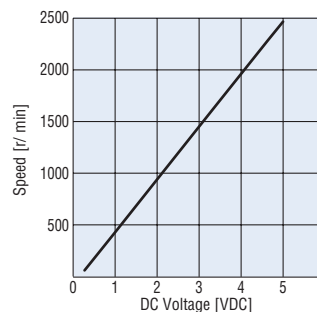
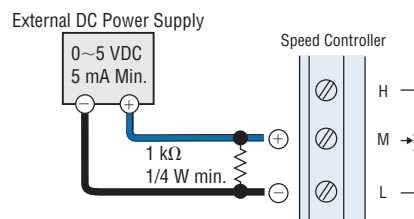

External DC Voltage - Speed Characteristics (Representative values)

■ List of Motor and Speed Controller Combinations

Model name for motor, gearhead and speed controller combinations are shown below.

● Speed Control Motor and Controller Package

◇ Combination Type

Model	Motor Model	Gearhead Model	Speed Controller Model
BHF62AT-□RH	BHM62T-G2	BH6G2-□RH	FSP200-1
BHF62AT-□RA		BH6G2-□RA	
BHF62AT-□		BH6G2-□	
BHF62CT-□RH		BH6G2-□RH	FSP200-2
BHF62CT-□RA		BH6G2-□RA	
BHF62CT-□		BH6G2-□	
BHF62ST-□RH		BH6G2-□RH	FSP200-3
BHF62ST-□RA		BH6G2-□RA	
BHF62ST-□		BH6G2-□	

◇ Round Shaft Type

Model	Motor Model	Speed Controller Model
BHF62AT-A	BHM62T-A	FSP200-1
BHF62CT-A		FSP200-2
BHF62ST-A		FSP200-3

● Speed Control Motor and Controller Package with Electromagnetic Brake

◇ Combination Type

Model	Motor Model	Gearhead Model	Speed Controller Model
BHF62AMT-□RH	BHM62MT-G2	BH6G2-□RH	FSP200-1
BHF62AMT-□RA		BH6G2-□RA	
BHF62AMT-□		BH6G2-□	
BHF62CMT-□RH		BH6G2-□RH	FSP200-2
BHF62CMT-□RA		BH6G2-□RA	
BHF62CMT-□		BH6G2-□	
BHF62SMT-□RH		BH6G2-□RH	FSP200-3
BHF62SMT-□RA		BH6G2-□RA	
BHF62SMT-□		BH6G2-□	

◇ Round Shaft Type

Model	Motor Model	Speed Controller Model
BHF62AMT-A	BHM62MT-A	FSP200-1
BHF62CMT-A		FSP200-2
BHF62SMT-A		FSP200-3

● Enter the gear ratio in the box (□) within the model name.

Introduction	
BX	Brushless Motors
BLF	
BLE	
BLU	
BLH	DC Input
BLV	
BHF	AC Speed Control Motors
FE100 / FE200	
ES01 / ES02	
US	
Accessories	
Installation	