



Torque Motors

Additional Information

Technical Reference	F-1
General Information	G-1

Torque Motors

Torque motors are designed to provide high starting torque and sloping characteristics (torque is highest at zero speed and decreases steadily with increasing speed), and operate over a wide speed range. They also provide stable operation, especially in the low speed range or under a locked rotor condition.

Features

Speed can be varied over a wide range

The motor torque is approximately proportional to the square of the voltage, allowing easy speed control simply by changing the voltage of the power supply.

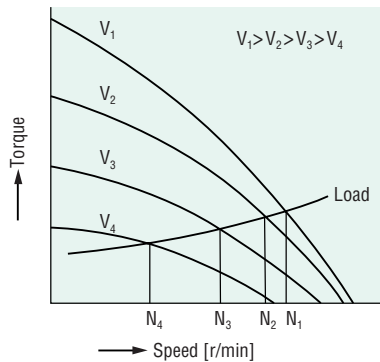

Suitable for winding applications

In an application where an object is released continuously at a constant speed and wound up with constant tension, the torque must be doubled and the speed must be halved if the diameter of the winding spool is doubled.

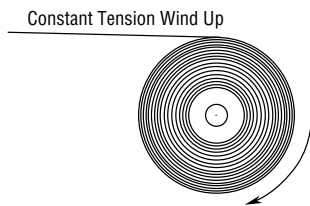

Locked rotor operation is available

Unlike induction motors or reversible motors, torque motors are designed to provide a stable torque even under stall conditions or at very low speeds (nearly stalling). They are suitable for pushing applications that require static torque, or for loads that are usually under a locked rotor condition but are under stall conditions at the end of processes. The motors can operate continuously at 60 VAC or less. When used at voltages above 60 VAC, the motors are rated for limited duty. The motor has a 5-minute rating at 115 VAC.

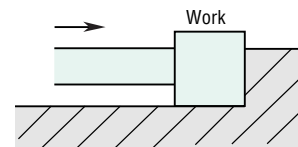

Note:

- When using a motor in a locked rotor condition, the output torque becomes very large. Do not exceed the permissible torque of the gearhead. Also, ensure that the work does not hit an object and stop, since this can cause damage to the gearhead due to the shock.

Use as a brake

By using the motor in the braking region of the speed-torque characteristics, it can serve as a brake. Constant tension operation can be achieved by applying a DC voltage.

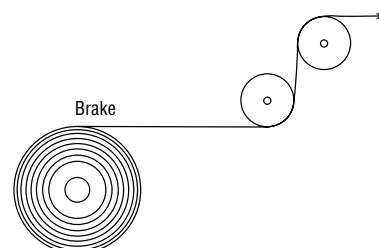

System Configuration

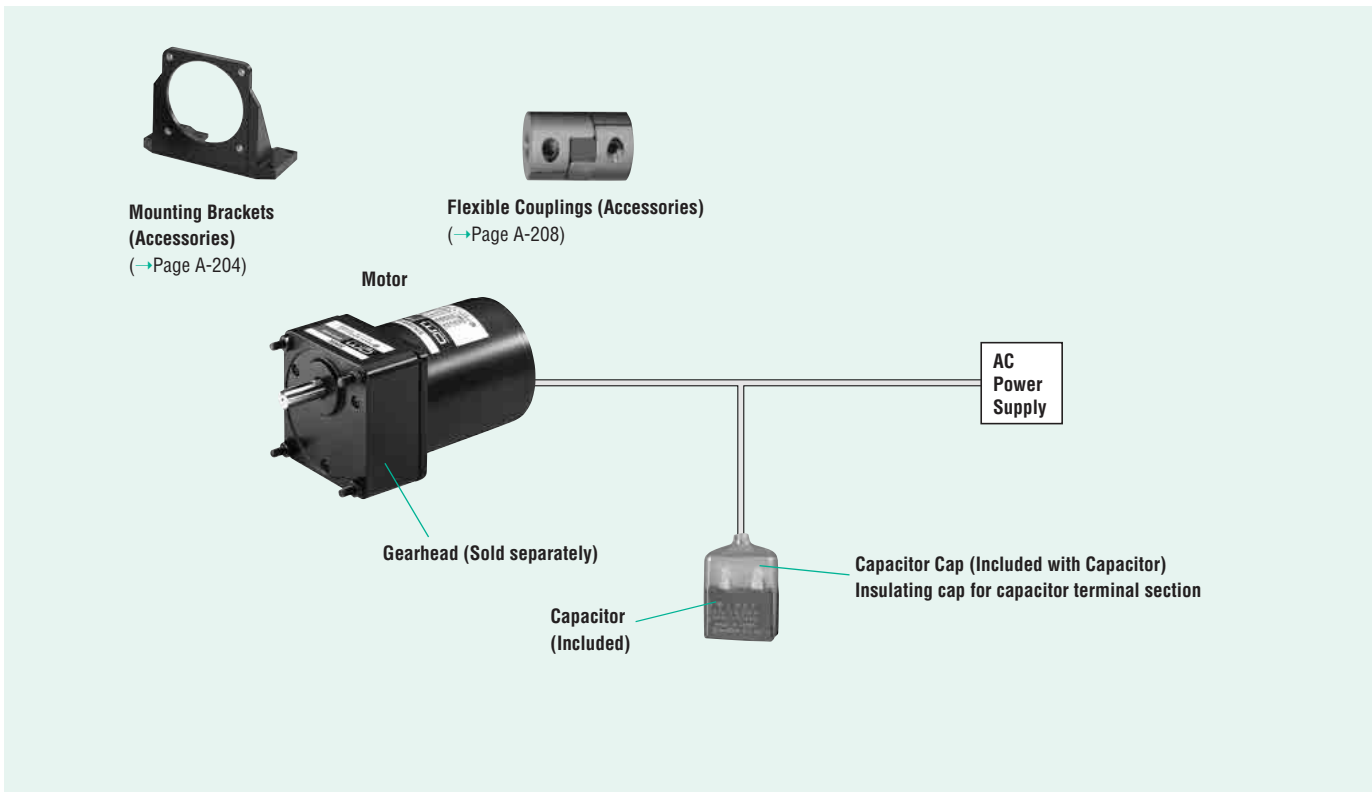

The system configuration shown above is an example. Other configurations are available.

Product Number Code

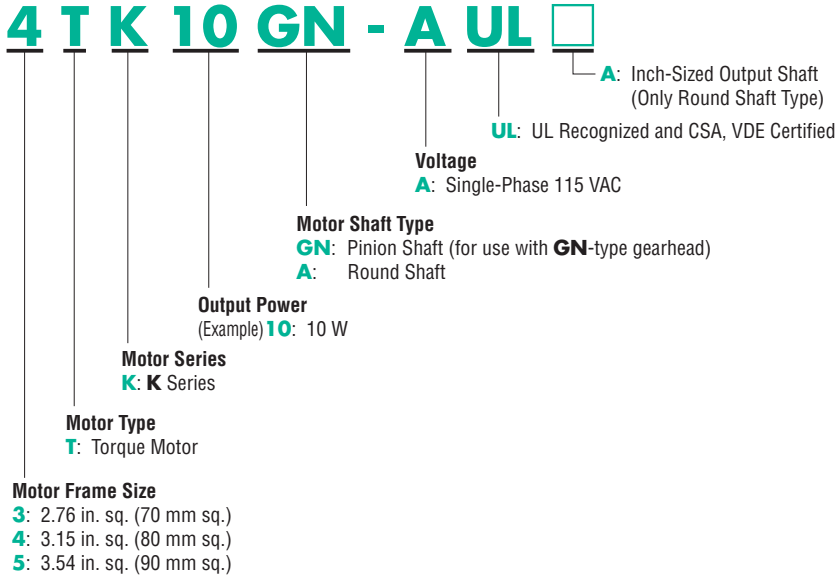

• Gearhead Product Number Code →Page A-16

Safety Standards and CE Marking

Standards	Certification Body	Standards File No.	CE Marking
UL1004 UL547	UL	E64197	Low Voltage Directives
CSA C22.2 No.100 CSA C22.2 No.77	CSA	LR47296	
EN60950	VDE	5877ÜG	

• Details of Safety Standards →Page G-2

How to Read Speed–Torque Characteristics Graph

The torque generated by the torque motor changes approximately proportionally to the square of the voltage. When the voltage supplied to the motor is changed, speed-torque curves with a sloping characteristics (torque is highest at zero speed and decreases steadily with increasing speed) shifts to that of the corresponding voltage.

When the voltage is changed to 115 VAC, 80 VAC and 60 VAC while the load torque is T_0 , the motor rotates at the speeds N_1 , N_2 and N_3 respectively. Thus, the speed can be changed easily by varying the voltage.

When choosing a torque motor, first determine the required torque and speed. Then select a motor using the speed-torque characteristics curves to determine whether the motor should be operated under continuous duty or limited duty.

When used under locked rotor conditions, only the torque factor is considered.

The temperature rise of the motor may cause a problem during continuous operation. In this case, choose a motor with an output power large enough for continuous operation and adjust the voltage to control the torque and speed.

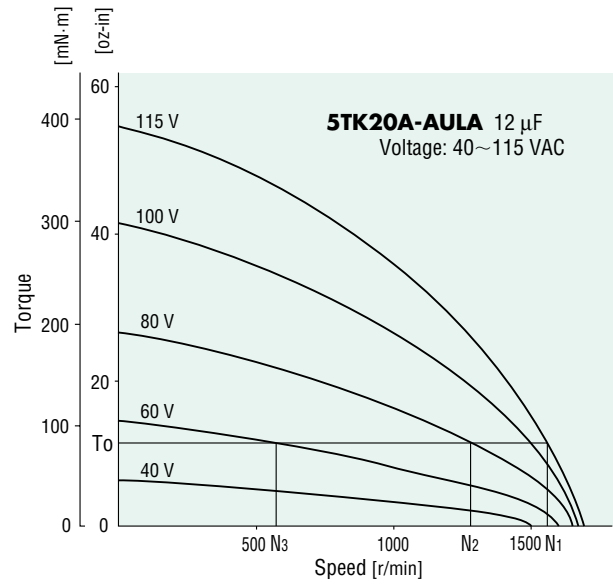

Voltage Control of Torque Motors

The method most commonly used to control voltage is by phase control using a triac. As shown in the figure to the right, by changing the phase angle “alpha” at which the triac switches, the input voltage is controlled as represented by the phase angle areas of the graph.

- When adjusting the speed or the torque, an external voltage adjuster is necessary.

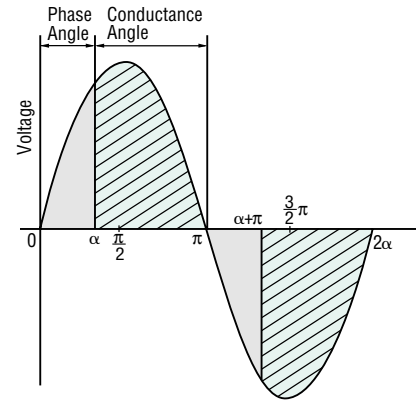

Phase Control

Specifications



Model		Rating at Locked Rotor	Voltage VAC	Frequency Hz	Starting Torque oz-in	Output Power	At max. output power					Capacitor μF		
Pinion Shaft Type	Round Shaft Type						Speed r/min	Torque oz-in	Torque mN·m	Current A	Input W			
ⓉP	3TK6GN-AUL	3TK6A-AULA	5 minutes Single-phase 115	60	21	150	1/93	8	900	12.3	87	0.62	67	8.0
			Continuous Single-phase 60		6.3	45	1/300	2.5	3.8	27	0.34	20		
ⓉP	4TK10GN-AUL	4TK10A-AULA	5 minutes Single-phase 115	60	27	195	1/62	12	900	18.4	130	0.66	70	8.0
			Continuous Single-phase 60		7.1	50	1/270	2.8	4.4	31	0.32	19		
ⓉP	5TK20GN-AUL	5TK20A-AULA	5 minutes Single-phase 115	60	49	350	1/32	23	900	35	250	1.0	110	12.0
			Continuous Single-phase 60		12.7	90	1/125	6	9.2	65	0.49	29		

ⓉP Contains a built-in thermal protector. If a motor overheats for any reason, the thermal protector is opened and the motor stops. When the motor temperature drops, the thermal protector closes and the motor restarts. Be sure to turn the motor off before inspecting.

General Specifications

Item	Specifications
Insulation Resistance	100 MΩ or more when 500 VDC is applied between the windings and the frame after rated motor operation under normal ambient temperature and humidity.
Dielectric Strength	Sufficient to withstand 1.5 kV at 60 Hz applied between the windings and the frame for 1 minute after rated motor operation under normal ambient temperature and humidity.
Temperature Rise	135°F (75°C) or less measured by the resistance change method after rated motor operation.
Insulation Class	UL/CSA Standard Class A [221°F (105°C)], EN Standard Class E [248°F (120°C)].
Overheat Protection	Built-in thermal protector (Automatic return type) Operating temperature, open: 248°F±9°F (120°C±5°C) close: 170.6°F±27°F (77°C±15°C)
Ambient Temperature Range	14°F~104°F (-10°C~+40°C)(nonfreezing)
Ambient Humidity	85% maximum (noncondensing)
Degree of Protection	IP20

Gearheads (Sold Separately)

Parallel Shaft

Model	Gear Ratio
3GN□KA	3~180
3GN10XK (Decimal Gearhead)	
4GN□KA	3~180
4GN10XK (Decimal Gearhead)	
5GN□KA	3~180
5GN10XK (Decimal Gearhead)	

- Enter the gear ratio in the box (□) within the model name.

Gearmotor–Torque Table

The permissible torque when a gearhead and a decimal gearhead are directly connected can be calculated according to the following formula, using the speed and torque determined from the speed-torque characteristics.

$$\text{Speed of gearhead output shaft } N_G = \text{Motor speed} \times 1/\text{gearhead gear ratio}$$

$$\text{Output torque of gearhead } T_G = \text{Motor torque} \times \text{Gearhead gear ratio} \times \text{Gearhead efficiency}$$

The output torque of the gearhead must be lower than the maximum permissible torque.

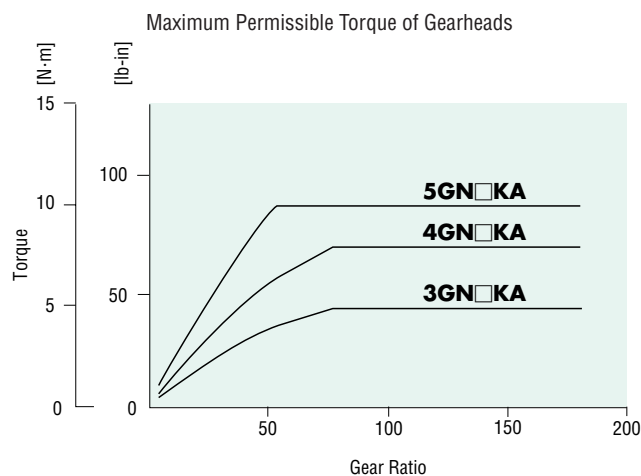

Gearhead Model	Gearhead Gear Ratio	Gearhead Efficiency
3GN□KA	3, 3.6, 5, 6, 7.5, 9, 12.5, 15, 18	81%
4GN□KA	25, 30, 36	73%
5GN□KA	50, 60, 75, 90, 100, 120, 150, 180	66%

- Gearheads and decimal gearheads are sold separately.
- Enter the gear ratio in the box (□) within the model name.

Speed – Torque Characteristics (Reference Values)

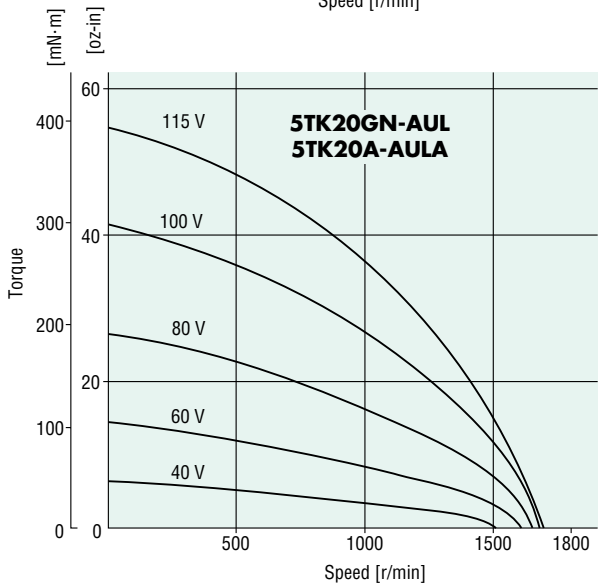
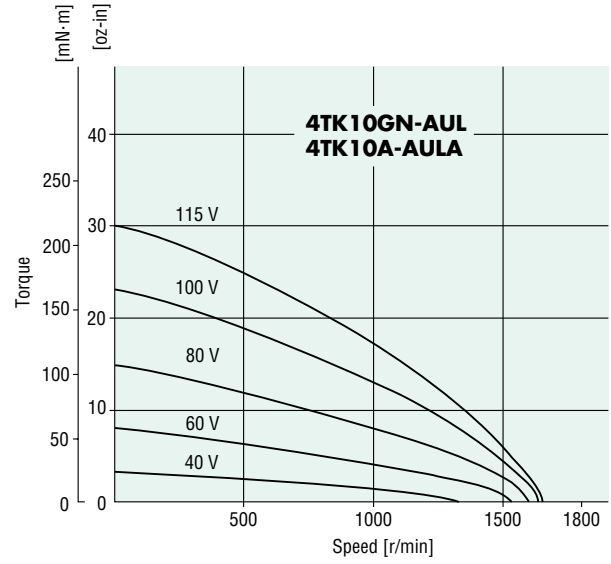
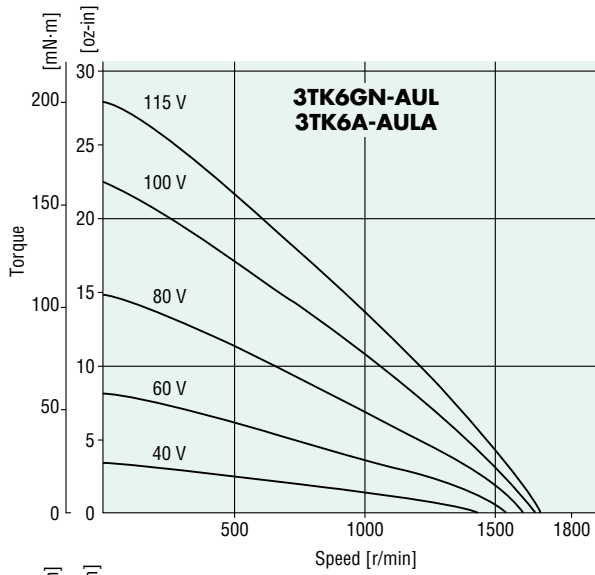

Dimensions Scale 1/4, Unit = inch (mm)

- **Motor**
- **Gearhead**
- 3TK6GN-AUL** **3GN□KA**
- Weight: 2.4 lb. (1.1 kg) Weight: 1.2 lb. (0.55 kg)
- DXF** A010AU (**3GN3KA~18KA**)
- A010BU (**3GN25KA~180KA**)

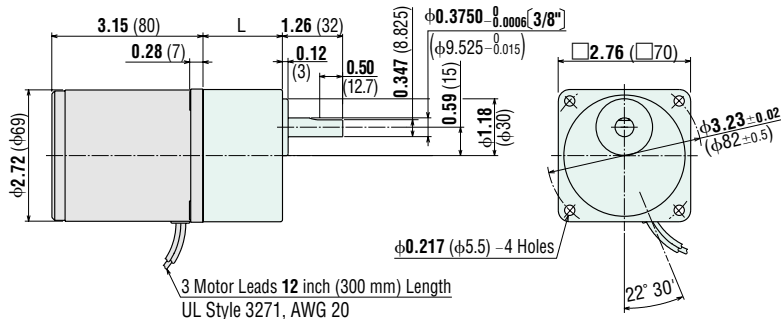

3GN3KA~18KA: L = 1.26 (32)
3GN25KA~180KA: L = 1.65 (42)

● Round Shaft Type

3TK6A-AULA

Weight: 2.4 lb. (1.1 kg)

DXF A326U

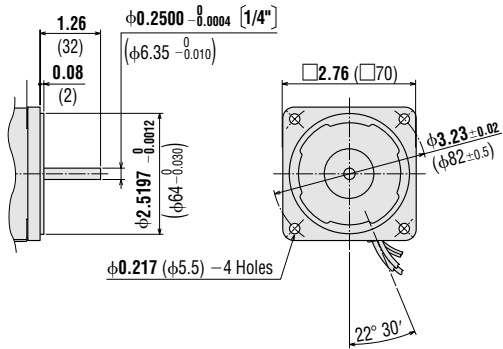

● Decimal Gearhead

(For 3TK6GN-AUL)

3GN10XK

Weight: 0.66 lb. (0.3 kg)

DXF A009

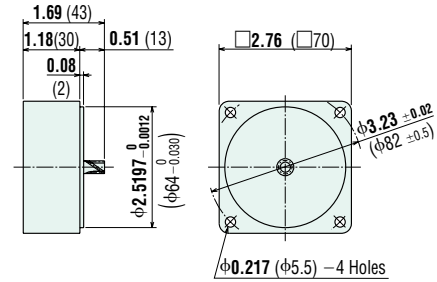

● Motor

4TK10GN-AUL

Weight: 3.3 lb. (1.5 kg)

DXF A014AU (4GN3KA~18KA)

A014BU (4GN25KA~180KA)

Gearhead

4GN□KA

Weight: 1.4 lb. (0.65 kg)

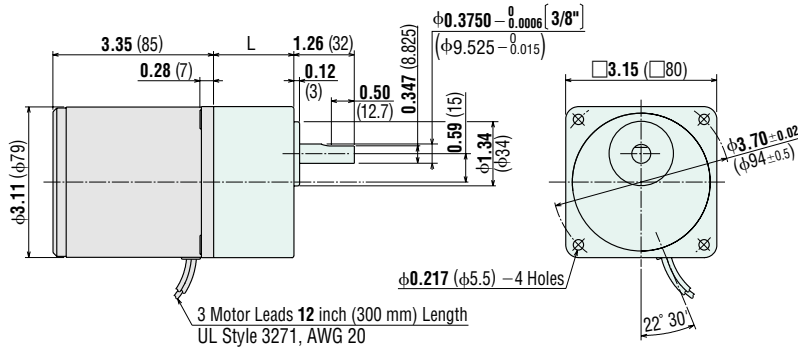

4GN3KA-18KA: L = 1.26 (32)
4GN25KA-180KA: L = 1.67 (42.5)

● Round Shaft Type

4TK10A-AULA

Weight: 3.3 lb. (1.5 kg)

DXF A327U

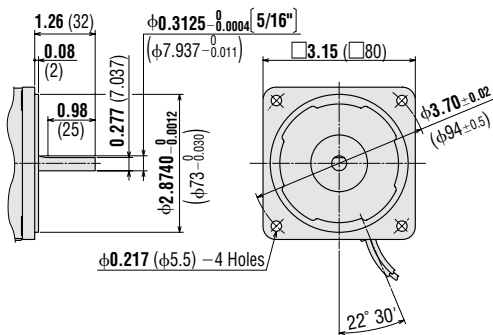

● Decimal Gearhead

(For 4TK10GN-AUL)

4GN10XK

Weight: 0.88 lb. (0.4 kg)

DXF A013

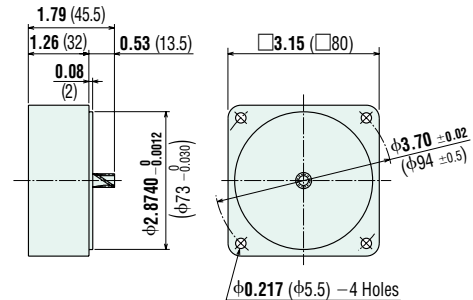

Introduction
Induction Motors
Reversible Motors
Synchronous Motors
Torque Motors
Watertight Motors
Magnetic Brake
Clutch & Brake
Brake Pack
Right-Angle Gearheads
Accessories
Before Using a Standard AC Motor

- **Motor**
5TK20GN-AUL
Weight: 5.5 lb. (2.5 kg)
- **Gearhead**
5GN□KA
Weight: 3.3 lb. (1.5 kg)
- **DXF** A019AU (**5GN3KA~18KA**)
A019BU (**5GN25KA~180KA**)

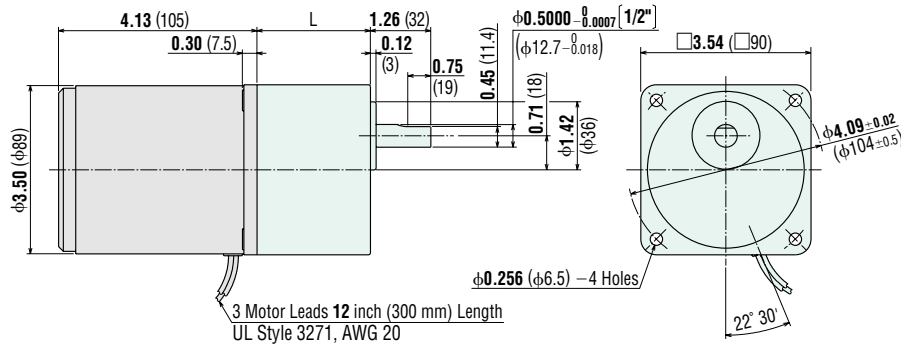

5GN3KA~18KA: L = 1.65 (42)
5GN25KA~180KA: L = 2.36 (60)

- **Round Shaft Type**
5TK20A-AULA

Weight: 5.5 lb. (2.5 kg)
● **DXF** A329U

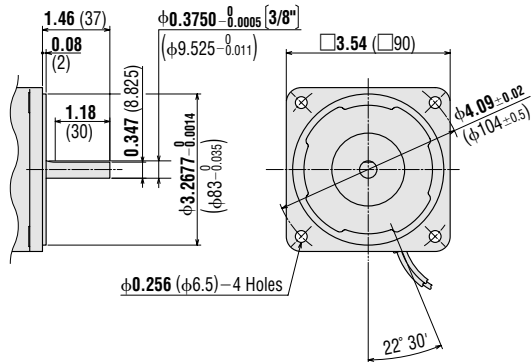

- **Decimal Gearhead**
(For **5TK20GN-AUL**)

5GN10XK
Weight: 1.3 lb. (0.6 kg)
● **DXF** A022

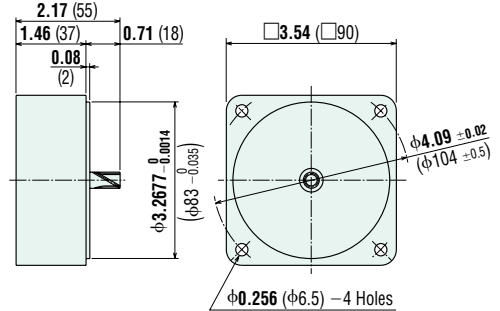

- **Capacitor** (included with the motors)

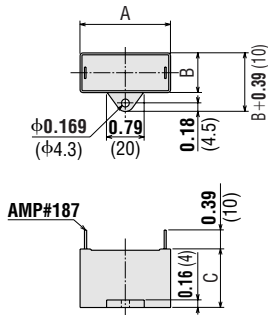

Motor Model	Capacitor Model	Dimensions in. (mm)			Weight oz. (g)
		A	B	C	
3TK6GN-AUL	CH80UL	1.50	0.83	1.22	1.2 (35)
3TK6A-AULA		(38)	(21)	(31)	
4TK10GN-AUL	CH80UL	1.50	0.83	1.22	1.2 (35)
4TK10A-AULA		(38)	(21)	(31)	
5TK20GN-AUL	CH120CUL	2.28	0.83	1.22	1.8 (50)
5TK20A-AULA		(58)	(21)	(31)	

• If you need to order a capacitor with out a motor, add “-C” to the capacitor model name shown. A capacitor cap is included with the capacitor.

Connection Diagram

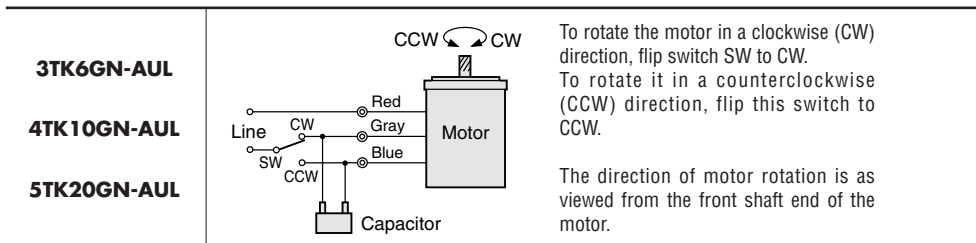

- The direction of motor rotation is as viewed from the shaft end of the motor.
- CW represents the clockwise direction, while CCW represents the counterclockwise direction.
- Connection diagrams are also valid for the equivalent round shaft motors.
- **How to connect a capacitor** → Page A-225