



New 5-Phase Stepping Motor and Driver Package

**RK II Series**

Built-in controller type

**OPERATING MANUAL Driver**



## Introduction

### ■ Before use

Only qualified personnel should work with the product. Use the product correctly after thoroughly reading the section "Safety precautions".

The product described in this manual has been designed and manufactured for use in general industrial equipment. Do not use for any other purpose. Oriental Motor Co., Ltd. is not responsible for any damage caused through failure to observe this warning.

### ■ Operating manuals for the RK II Series

Operating manuals for the **RK II** Series are listed below.

- **RK II Series**  
Instructions and Precautions for Safe Use Motor
- **RK II Series FLEX Built-in controller type**  
OPERATING MANUAL Driver (this document)
- **RK II Series FLEX Built-in controller type**  
USER MANUAL

### ■ Hazardous substances

The products do not contain the substances exceeding the restriction values of RoHS Directive (2011/65/EU).

## Safety precautions

The precautions described below are intended to prevent danger or injury to the user and other personnel through safe, correct use of the product. Use the product only after carefully reading and fully understanding these instructions.

### Description of signs

	Handling the product without observing the instructions that accompany a "Warning" symbol may result in serious injury or death.
	Handling the product without observing the instructions that accompany a "Caution" symbol may result in injury or property damage.

### Description of graphic symbols



	Indicates "prohibited" actions that must not be performed.
	Indicates "compulsory" actions that must be performed.



Thank you for purchasing an Oriental Motor product. This Manual describes product handling procedures and safety precautions.

- Please read it thoroughly to ensure safe operation.
- Always keep the manual where it is readily available.

### Warning

	Do not use the product in explosive or corrosive environments, in the presence of flammable gases, locations subjected to splashing water, or near combustibles. This may cause fire, electric shock or injury.
	Do not transport, install the product, perform connections or inspections when the power is on. This may cause electric shock.
	Do not touch the driver while the power is on. This may cause fire or electric shock.
	The terminals on the driver's front panel marked with  symbol indicate the presence of high voltage. Do not touch these terminals while the power is on. This may cause fire or electric shock.
	Do not forcibly bend, pull or pinch the cable. This may cause fire or electric shock.
	Do not turn the AWO input or FREE input to ON while the motor is operating. This may cause injury or damage to equipment.
	Do not touch the connection terminals on the driver immediately (within 10 minute) after the power is turned off. This may cause electric shock.
	Do not disassemble or modify the product. This may cause injury or damage to equipment.
	Assign qualified personnel the task of installing, wiring, operating/controlling, inspecting and troubleshooting the product. Failure to do so may result in fire, electric shock, injury or damage to equipment.
	If this product is used in an vertical application, be sure to provide a measure for the position retention of moving parts. Failure to do so may result in injury or damage to equipment.
	When the driver generates an alarm (any of the driver's protective functions is triggered), first remove the cause and then clear the protection function. Continuing the operation without removing the cause of the problem may cause malfunction of the motor and driver, leading to injury or damage to equipment.
	Install the product in an enclosure. Failure to do so may result in electric shock or injury.
	The motor and driver are designed with Class I equipment basic insulation. When installing the motor and driver, do not touch the product or be sure to ground them. Failure to do so may result in electric shock.
	Keep the driver's input-power voltage within the specified range. Failure to do so may result in fire or electric shock.
	Connect the cables securely according to the wiring diagram. Failure to do so may result in fire or electric shock.
Turn off the driver power in the event of a power failure. Failure to do so may result in injury or damage to equipment.	

 <b>Warning</b>	
	Before making wiring connections or carrying out checks, wait for the CHARGE LED to turn off and check the voltage with a tester, etc. Failure to do so may result in electric shock.

 <b>Caution</b>	
	Do not use the product beyond its specifications. This may cause injury, electric shock or damage to equipment.
	Keep your fingers and objects out of the openings in the product. Failure to do so may result in fire, electric shock or injury.
	Do not touch the product during operation or immediately after stopping. This may cause a skin burn(s).
	Do not forcibly bend or pull the cable that was connected to the driver. Doing so may cause damage.
	Keep the area around the product free of combustible materials. Failure to do so may result in fire or a skin burn(s).
	Leave nothing around the product that would obstruct ventilation. Failure to do so may result in damage to equipment.
	The data edit connector (CN4) and RS-485 communication connector (CN6/CN7) of the driver are not electrically insulated. When grounding the positive terminal of the power supply, do not connect any equipment (PC, etc.) whose negative terminal is grounded. This may cause the driver and these equipment to short, damaging both.
	Do not touch the terminals while performing the insulation resistance test or dielectric strength test. This may cause electric shock.
	Use a motor and driver only in the specified combination. Failure to do so may result in fire.
	For the 24 VDC power supply, use a DC power supply with reinforced insulation on its primary and secondary sides. Failure to do so may result in electric shock.
	Provide an emergency stop device or emergency stop circuit external to the equipment so that the entire equipment will operate safely in the event of a system failure or malfunction. Failure to do so may result in injury.
	Before supplying power to the driver, turn all input signals to the driver to OFF. Failure to do so may result in injury or damage to equipment.
	Before moving the motor directly with the hands, confirm that the AWO input or FREE input turns ON. Failure to do so may result in injury.
	When an abnormal condition has occurred, immediately stop operation and turn off the driver power. Failure to do so may result in fire, electric shock or injury.
	Use only an insulated screwdriver to adjust the driver's switches. Failure to do so may result in electric shock.
	To dispose of the driver, disassemble it into parts and components as much as possible and dispose of individual parts/components as industrial waste.

## Precautions for use

This section covers limitations and requirements the user should consider when using the product.

- Always use the cable (supplied or accessory) to connect the motor and driver.

Be sure to use the cable (supplied or accessory) to connect the motor and driver. If a cable other than the supplied cable or accessory cable (sold separately) is used, the driver may generate a large amount of heat. In the following condition, an appropriate accessory cable must be purchased separately.

- If a flexible cable is to be used.
- If a cable of 3 m (9.8 ft.) or longer is to be used.
- If a motor and driver package without a cable was purchased.
- Perform the insulation resistance test or dielectric strength test separately on the motor and the driver.

Performing the insulation resistance test or dielectric strength test with the motor and driver connected may result in damage to the product.

- Preventing leakage current

Stray capacitance exists between the driver's current-carrying line and other current-carrying lines, the earth and the motor, respectively. A high-frequency current may leak out through such capacitance, having a detrimental effect on the surrounding equipment. The actual leakage current depends on the driver's switching frequency, the length of wiring between the driver and motor, and so on.

When connecting an earth leakage breaker, use one of the following products offering resistance against high frequency current:  
Mitsubishi Electric Corporation: NV series  
Fuji Electric FA Components & Systems Co., Ltd.: EG and SG series

- Preventing electrical noise

See USER MANUAL for measures with regard to noise.

- Saving data to the non-volatile memory

Do not turn off the 24 VDC power supply while writing the data to the non-volatile memory and 5 seconds after the completion of writing the data. Doing so may abort writing the data and cause a EEPROM error alarm to generate. The non-volatile memory can be rewritten approximately 100,000 times.

- Motor excitation at power ON

The motor is excited when the 24 VDC power and main power is on. If the motor is required to be in non-excitation status when turning on the power, assign the AWO input to the direct I/O or network I/O.

- Note on connecting a power supply whose positive terminal is grounded

The data edit connector (CN4) and RS-485 communication connector (CN6/CN7) of the driver are not electrically insulated. When grounding the positive terminal of the power supply, do not connect any equipment (PC, etc.) whose negative terminal is grounded. Doing so may cause the driver and these equipment to short, damaging both. Use the data setter **OPX-2A** to set data, etc.

## General specifications

Degree of protection		IP10
Operation environment	Ambient temperature	0 to +55 °C (+32 to +131 °F) * (non-freezing)
	Humidity	85% or less (non-condensing)
	Altitude	Up to 1000 m (3300 ft.) above sea level
	Surrounding atmosphere	No corrosive gas, dust, water or oil

Storage environment Shipping environment	Ambient temperature	-25 to +70 °C (-13 to +158 °F) (non-freezing)
	Humidity	85% or less (non-condensing)
	Altitude	Up to 3000 m (10000 ft.) above sea level
	Surrounding atmosphere	No corrosive gas, dust, water or oil

\* When installing a driver on a heat sink.  
[material: aluminium, 200×200×2 mm (7.87×7.87×0.08 in.)]

Insulation resistance	100 MΩ or more when 500 VDC megger is applied between the following places: • PE terminal - Power supply terminals • Signal I/O terminals - Power supply terminals
Dielectric strength	Sufficient to withstand the following for 1 minute: • PE terminal - Power supply terminals 1.5 kVAC 50/60 Hz • Signal I/O terminals - Power supply terminals 1.8 kVAC 50/60 Hz

## CE Marking

This product is affixed the CE Marking under the Low Voltage Directive and EMC Directive.

### Low Voltage Directives

- The product is a type with machinery incorporated, so it should be installed within an enclosure.
- This product cannot be used with cables normally used for IT equipment.
- Install the product within the enclosure in order to avoid contact with hands.
- Be sure to maintain a protective ground in case hands should make contact with the product. Be sure to connect the Protective Earth lead of the cable for motor to the Protective Earth Terminal on the driver, and ground the driver's Protective Earth Terminal.
- To protect against electric shock using an earth leakage breaker (RCD), connect a type B earth leakage breaker to the primary side of the driver.
- When using a circuit breaker (MCCB), use a unit conforming to the EN or IEC standard.
- Isolate the motor cable, power-supply cable and other drive cables from the signal cables (CN1, CN4 to CN9) by means of double insulation.
- The temperature of the driver's heat sink may exceed 90 °C (194 °F) depending on the driving conditions. Accordingly, take heed of the following items:
  - Do not touch the driver.
  - Do not use the driver near flammable objects.
  - Always conduct a trial operation to check the driver temperature.

### Applicable Standard

EN 61800-5-1

- Installation conditions (EN Standard)
- Driver is to be used as a component within other equipment.
- Overvoltage category: II
- Pollution degree: 2
- Degree of protection: IP10
- Protection against electric shock: Class I

### EMC Directive

This product has received EMC compliance under the conditions specified in "Example of motor and driver installation and wiring." Since the compliance of the final machinery with the EMC Directive will depend on such factors as the configuration, wiring, layout and risk involved in the control-system equipment and electrical parts, it therefore must be verified through EMC measures by the customer of the machinery.

### Applicable Standards

- EMI: EN 55011 Group1 Class A, EN 61000-6-4, EN 61800-3, EN 61000-3-2, EN 61000-3-3
- EMS: EN 61000-6-2, EN 61800-3

This type of PDS is not intended to be used on a low-voltage public network which supplies domestic premises; radio frequency interference is expected if used on such a network.

## Preparation

### Checking the product

Verify that the items listed below are included. Report any missing or damaged items to the branch or sales office from which you purchased the product.

- Driver .....1 unit
- CN1 connector (4 pins) .....1 pc.
- CN3 connector (3 pins) .....1 pc.
- CN5 connector (5 pins) .....1 pc.
- CN8 connector (9 pins) .....1 pc.
- CN9 connector (7 pins) .....1 pc.
- OPERATING MANUAL Driver.....1 copy (this document)

### Combinations of motors and drivers

- □ indicates **A** (single shaft), **B** (double shaft) or **M** (with electromagnetic brake).  
For geared type, □ indicates **A** (single shaft) or **M** (with electromagnetic brake).
- ■ indicates **A** (single-phase 100-120 V) or **C** (single-phase 200-240 V).
- ● represents a number indicating the gear ratio.
- ○ indicates the cable length (**-1**, **-2**, **-3**) when the connection cable is supplied.

### Standard type

Model	Motor model	Driver model
RKS543□■D○	PKE543□C	RKSD503-■D
RKS544□■D○	PKE544□C	
RKS545□■D○	PKE545□C	
RKS564□■D○	PKE564□C	RKSD507-■D
RKS566□■D○	PKE566□C	
RKS569□■D○	PKE569□C	
RKS596□■D○	PKE596□C	
RKS599□■D○	PKE599□C	
RKS5913□■D○	PKE5913□C	

### Standard type with encoder

Model	Motor model	Driver model
RKS543R■D2○	PKE543RC2	RKSD503-■D
RKS544R■D2○	PKE544RC2	
RKS545R■D2○	PKE545RC2	
RKS564R■D2○	PKE564RC2	RKSD507-■D
RKS566R■D2○	PKE566RC2	
RKS569R■D2○	PKE569RC2	
RKS596R■D2○	PKE596RC2	
RKS599R■D2○	PKE599RC2	
RKS5913R■D2○	PKE5913RC2	

• TS geared type

Model	Motor model	Driver model
RKS543□■D-TS●○	PKE543□C-TS●	RKSD503-■D
RKS564□■D-TS●○	PKE564□C-TS●	RKSD507-■D
RKS596□■D-TS●○	PKE596□C-TS●	

• PS geared type

Model	Motor model	Driver model
RKS543□■D-PS●○	PKE543□C-PS●	RKSD503-■D
RKS545□■D-PS●○	PKE545□C-PS●	
RKS564□■D-PS●○	PKE564□C-PS●	RKSD507-■D
RKS566□■D-PS●○	PKE566□C-PS●	
RKS596□■D-PS●○	PKE596□C-PS●	
RKS599□■D-PS●○	PKE599□C-PS●	

• Harmonic geared type

Model	Motor model	Driver model
RKS543□■D-HS●○	PKE543□C-HS●	RKSD503-■D
RKS564□■D-HS●○	PKE564□C-HS●	RKSD507-■D
RKS596□■D-HS●○	PKE596□C-HS●	

■ Names and functions of parts

• Driver front side

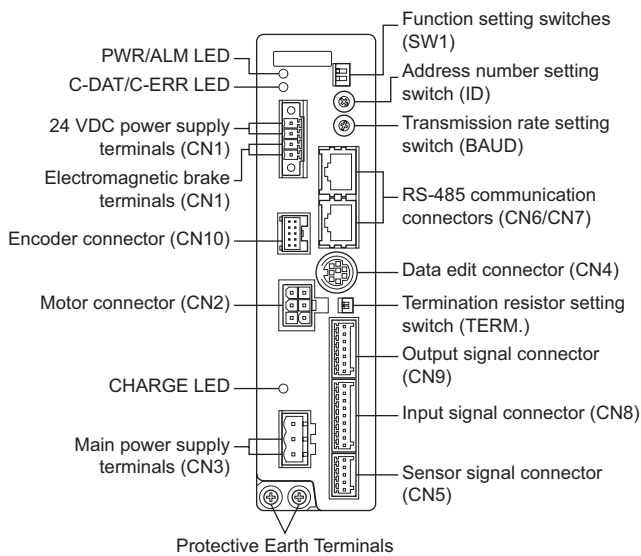

• Driver rear side

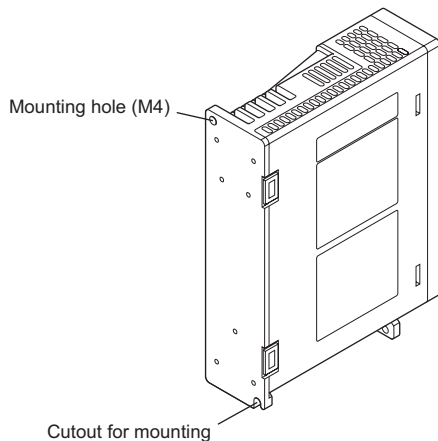

Installation

■ Location for installation

The driver has been designed and manufactured to be installed within another device. Install them in a well-ventilated location that provides easy access for inspection.

The location must also satisfy the following conditions:

- Inside an enclosure that is installed indoors (provide vent holes)
- Operating ambient temperature 0 to +55 °C (+32 to +131 °F) (non-freezing)
- Operating ambient humidity 85% or less (non-condensing)
- Area that is free of explosive atmosphere or toxic gas (such as sulfuric gas) or liquid
- Area not exposed to direct sun
- Area free of excessive amount of dust, iron particles or the like
- Area not subject to splashing water (rain, water droplets), oil (oil droplets) or other liquids
- Area free of excessive salt
- Area not subject to continuous vibration or excessive shocks
- Area free of excessive electromagnetic noise (from welders, power machinery, etc.)
- Area free of radioactive materials, magnetic fields or vacuum
- 1000 m (3300 ft.) or lower above sea level

■ Installation method

The driver is designed so that heat is dissipated via air convection and conduction through the enclosure.

Install the driver on a flat metal plate [material: aluminium, 200×200×2 mm (7.87×7.87×0.08 in.) equivalent ] having excellent heat conductivity.

There must be a clearance of at least 25 mm (0.98 in.) in the horizontal and vertical directions, between the driver and enclosure or other equipment within the enclosure. When two or more drivers are to be installed side by side, provide 20 mm (0.79 in.) and 25 mm (0.98 in.) clearances in the horizontal and vertical directions, respectively.

When installing two or more drivers in parallel, it is possible to install them closely in the horizontal direction. In this case, use the drivers in conditions that an ambient temperature is 0 to +40 °C (+32 to +104 °F) and the standstill current is 50% or less.

When installing the driver in an enclosure, use two screws (M4, not supplied) to secure the driver through the mounting holes.

- When installing drivers while keeping clearances in the horizontal and vertical directions.
- When installing drivers closely in the horizontal direction.

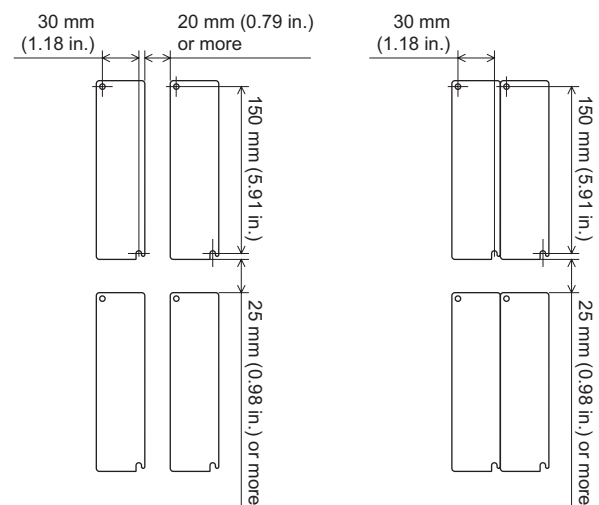



**Note**

- Install the driver in an enclosure whose pollution degree is 2 or better environment, or whose degree of protection is IP54 minimum.
- Do not install any equipment that generates a large amount of heat or noise near the driver.
- Do not install the driver underneath the controller or other equipment vulnerable to heat.
- If the ambient temperature of the driver exceeds 55 °C (131 °F), improve the ventilation condition. Also, when the standstill current is set to 60%, use the driver in a condition that an ambient temperature does not exceed 50 °C (122 °F).
- Be sure to install the driver vertically (vertical position).

**Connection**

**Note**

- Have the connector plugged in securely. Insecure connections may cause malfunction or damage to the motor or driver.
- When unplugging the motor or encoder connector, do so while pressing the latches on the connector.
- When plugging/unplugging the connector, turn off the power and wait for the CHARGE LED to turn off before doing so. Residual voltage may cause electric shock.
- Do not wire the power supply cable of the driver in the same cable duct with other power lines or motor cables. Doing so may cause malfunction due to noise.
- The lead wires of the "cable for electromagnetic brake" have polarities, so connect them in the correct polarities. If the lead wires are connected with their polarities reversed, the electromagnetic brake will not operate properly.
- If the distance between the motor and driver is extended to 15 m (49.2 ft.) or longer, use a power supply of 24 VDC±4%.
- When installing the motor to a moving part, use an accessory flexible cable offering excellent flexibility.

**■ Connection example of standard type with electromagnetic brake**

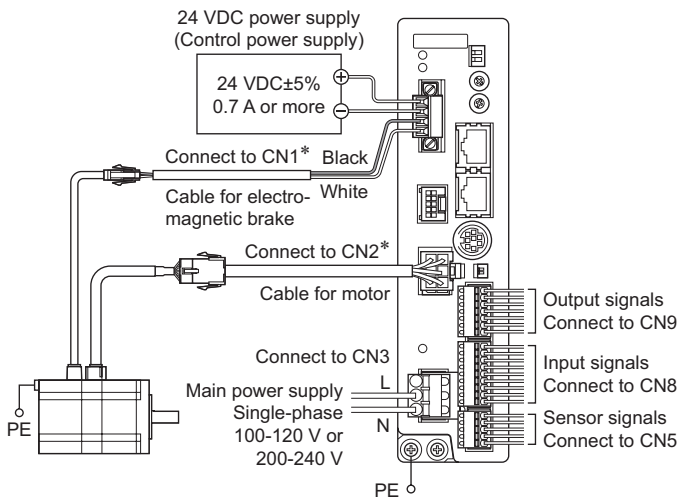

\* Keep 20 m (65.6 ft.) or less for the wiring distance between the motor and driver.

**■ Connection example of standard type with encoder**

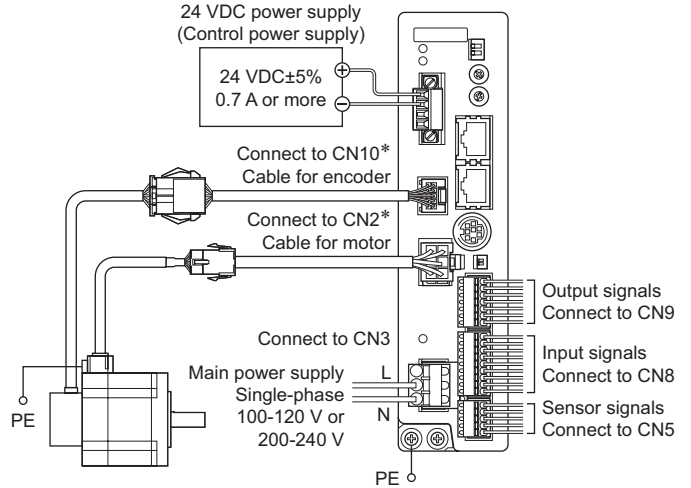

\* Keep 20 m (65.6 ft.) or less for the wiring distance between the motor and driver.

**■ Wiring method of connector**

**• CN1 connector**

1. Insert the lead wire into the CN1 connector and tighten the screw using a screwdriver.
2. Insert the CN1 connector into CN1 and tighten the screws.

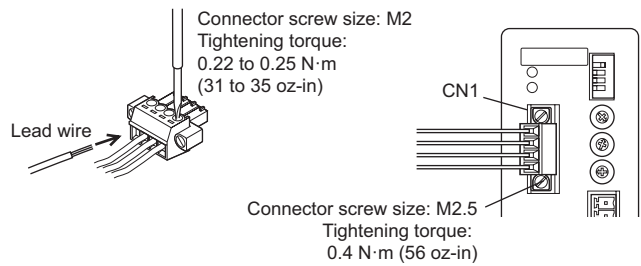

**• CN5, CN8, CN9 connector**

1. Insert the lead wire while pushing the button of the orange color with a screwdriver.
2. After having inserted, release the button to secure the lead wire.

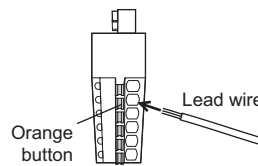

**■ Pin assignment list**

**• CN1**

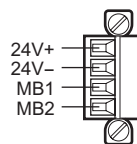

- Applicable lead wire: AWG28 to 16 (0.08 to 1.25 mm<sup>2</sup>)
- Length of the insulation cover which can be peeled: 7 mm (0.28 in.)

Display	Description
24V+	Connect the 24 VDC. 24 VDC±5% 0.7 A or more
24V-	
MB1	Connect the "cable for electromagnetic brake"
MB2	

• CN3

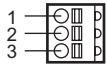

- Applicable lead wire: AWG16 to 14 (1.25 to 2.0 mm<sup>2</sup>)
- Length of the insulation cover which can be peeled: 10 mm (0.39 in.)

Pin No.	Display	Description
1	NC	Not used.
2	L	Connect the main power supply. • Single-phase 100-120 V -15 to +10% 50/60 Hz
3	N	• Single-phase 200-240 V -15 to +10% 50/60 Hz

• CN5

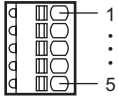

- Applicable lead wire: AWG26 to 20 (0.14 to 0.5 mm<sup>2</sup>)
- Length of the insulation cover which can be peeled: 8 mm (0.31 in.)

Pin No.	Signal name	Description
1	+LS	Limit sensor input +
2	-LS	Limit sensor input -
3	HOMES	Mechanical home sensor input
4	SLIT	Slit sensor input
5	IN-COM2	Sensor common input

• CN6/CN7

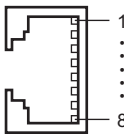

Pin No.	Signal name	Description
1	N.C.	Not used
2	GND	GND
3	TR+	RS-485 communication signal (+)
4	N.C.	Not used
5	N.C.	
6	TR-	RS-485 communication signal (-)
7	N.C.	Not used
8	N.C.	

• CN8

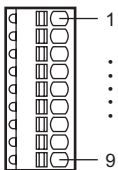

- Applicable lead wire: AWG26 to 20 (0.14 to 0.5 mm<sup>2</sup>)
- Length of the insulation cover which can be peeled: 8 mm (0.31 in.)

Pin No.	Signal name	Description *
1	IN0	Control input 0 [HOME]
2	IN1	Control input 1 [START]
3	IN2	Control input 2 [M0]
4	IN3	Control input 3 [M1]
5	IN4	Control input 4 [M2]
6	IN5	Control input 5 [FREE]
7	IN6	Control input 6 [STOP]
8	IN7	Control input 7 [ALM-RST]
9	IN-COM1	Input signal common

\* [ ]: Initial value

• CN9

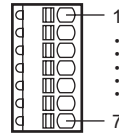

- Applicable lead wire: AWG26 to 20 (0.14 to 0.5 mm<sup>2</sup>)
- Length of the insulation cover which can be peeled: 8 mm (0.31 in.)

Pin No.	Signal name	Description *
1	OUT0	Control output 0 [HOME-P]
2	OUT1	Control output 1 [MOVE]
3	OUT2	Control output 2 [AREA1]
4	OUT3	Control output 3 [READY]
5	OUT4	Control output 4 [WNG]
6	OUT5	Control output 5 [ALM]
7	OUT-COM	Output signal common

\* [ ]: Initial value

■ Power supply current capacity

• Single-phase 100-120 V

Model	Power supply current capacity
RKS543	2.1 A or more
RKS544	1.9 A or more
RKS545	1.9 A or more
RKS564	4.0 A or more
RKS566	3.8 A or more
RKS569	4.0 A or more
RKS596	4.9 A or more
RKS599	3.5 A or more
RKS5913	3.5 A or more

• Single-phase 200-240 V

Model	Power supply current capacity
RKS543	1.3 A or more
RKS544	1.2 A or more
RKS545	1.2 A or more
RKS564	2.4 A or more
RKS566	2.4 A or more
RKS569	2.5 A or more
RKS596	3.0 A or more
RKS599	2.2 A or more
RKS5913	2.2 A or more

■ Grounding the driver

Be sure to ground the Protective Earth Terminal (screw size: M4) of the driver.

Grounding wire: AWG16 to 14 (1.25 to 2.0 mm<sup>2</sup>)

Tightening torque: 1.2 N·m (170 oz·in)

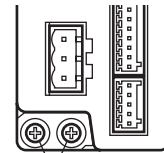

Protective Earth Terminal (Ground one of these terminals.)

You can ground either of the two Protective Earth Terminals. The terminal that is not grounded is used as a service terminal. Use the service terminal according to your specific need, such as connecting it to the motor in order to ground the motor.

Do not share the grounding wire with a welder or any other power equipment.

When grounding the Protective Earth Terminal, use a round terminal and affix the grounding point near the driver.

## Inspection

It is recommended that periodic inspections for the items listed below are conducted after each operation of the motor. If an abnormal condition is noted, discontinue any use and contact your nearest Oriental Motor sales office.

- During inspection
- Are the openings in the driver blocked?
- Are any of the mounting screws or connection parts of the driver loose?
- Is there attachment of dust, etc., on the driver?
- Are there any strange smells or appearances within the driver?

**Note** The driver uses semiconductor elements. Handle the driver with care since static electricity may damage semiconductor elements. Static electricity may damage the driver.

## Alarm (protective function)

When an alarm generates, the ALM output will turn OFF and the ALARM LED will start blinking. Before resetting an alarm, always remove the cause of the alarm and ensure safety.

For details of alarms, refer to [USER MANUAL](#).

- Unauthorized reproduction or copying of all or part of this manual is prohibited.
- Oriental Motor shall not be liable whatsoever for any problems relating to industrial property rights arising from use of any information, circuit, equipment or device provided or referenced in this manual.
- Characteristics, specifications and dimensions are subject to change without notice.
- While we make every effort to offer accurate information in the manual, we welcome your input. Should you find unclear descriptions, errors or omissions, please contact the nearest office.
- ***Orientalmotor*** is a registered trademark or trademark of Oriental Motor Co., Ltd., in Japan and other countries.

© Copyright ORIENTAL MOTOR CO., LTD. 2013

• Please contact your nearest Oriental Motor office for further information.

ORIENTAL MOTOR U.S.A. CORP.  
 Technical Support Tel:(800)468-3982  
 8:30 A.M. to 5:00 P.M., P.S.T. (M-F)  
 7:30 A.M. to 5:00 P.M., C.S.T. (M-F)  
[www.orientalmotor.com](http://www.orientalmotor.com)

ORIENTAL MOTOR DO BRASIL LTDA.  
 Tel:+55-11-3266-6018  
[www.orientalmotor.com.br](http://www.orientalmotor.com.br)

ORIENTAL MOTOR (EUROPA) GmbH  
 Schiessstraße 74, 40549 Düsseldorf, Germany  
 Technical Support Tel:00 800/22 55 66 22  
[www.orientalmotor.de](http://www.orientalmotor.de)

ORIENTAL MOTOR (UK) LTD.  
 Tel:01256-347090  
[www.oriental-motor.co.uk](http://www.oriental-motor.co.uk)

ORIENTAL MOTOR (FRANCE) SARL  
 Tel:01 47 86 97 50  
[www.orientalmotor.fr](http://www.orientalmotor.fr)

ORIENTAL MOTOR ITALIA s.r.l.  
 Tel:02-93906346  
[www.orientalmotor.it](http://www.orientalmotor.it)

ORIENTAL MOTOR CO., LTD.  
 4-8-1 Higashiueno, Taito-ku, Tokyo 110-8536  
 Japan  
 Tel:03-6744-0361  
[www.orientalmotor.co.jp](http://www.orientalmotor.co.jp)

ORIENTAL MOTOR ASIA PACIFIC PTE. LTD.  
 Singapore  
 Tel:1800-8420280  
[www.orientalmotor.com.sg](http://www.orientalmotor.com.sg)

ORIENTAL MOTOR (MALAYSIA) SDN. BHD.  
 Tel:1800-806161  
[www.orientalmotor.com.my](http://www.orientalmotor.com.my)

ORIENTAL MOTOR (THAILAND) CO., LTD.  
 Tel:1800-888-881  
[www.orientalmotor.co.th](http://www.orientalmotor.co.th)

ORIENTAL MOTOR (INDIA) PVT. LTD.  
 Tel:+91-80-41125586  
[www.orientalmotor.co.in](http://www.orientalmotor.co.in)

TAIWAN ORIENTAL MOTOR CO., LTD.  
 Tel:0800-060708  
[www.orientalmotor.com.tw](http://www.orientalmotor.com.tw)

SHANGHAI ORIENTAL MOTOR CO., LTD.  
 Tel:400-820-6516  
[www.orientalmotor.com.cn](http://www.orientalmotor.com.cn)

INA ORIENTAL MOTOR CO., LTD.  
 Korea  
 Tel:080-777-2042  
[www.inaom.co.kr](http://www.inaom.co.kr)

ORIENTAL MOTOR CO., LTD.  
 Hong Kong Branch  
 Tel:+852-2427-9800