

Brushless Motors

BLS Series Motor

DC power supply input

OPERATING MANUAL

Thank you for purchasing an Oriental Motor product.

This Operating Manual describes product handling procedures and safety precautions.

- Please read it thoroughly to ensure safe operation.
- Always keep the manual where it is readily available.

Table of contents

1	Introduction	2	6	Grounding.....	19
2	Safety precautions	3	7	Inspection and maintenance	20
3	Precautions for use	5	7.1	Inspection.....	20
4	Preparation	7	7.2	Warranty.....	20
4.1	Checking the product	7	7.3	Disposal	20
4.2	Model	8	8	Specifications.....	21
4.3	Information about nameplate.....	9	8.1	Specifications	21
4.4	Driver that can be combined.....	9	8.2	General specifications	21
4.5	Names of parts.....	9	9	Regulations and standards	22
5	Installation	10			
5.1	Installation location.....	10			
5.2	Installation method.....	11			
5.3	Installing a load.....	15			
5.4	Permissible radial load and permissible axial load.....	17			

1 Introduction

■ Before using the product

Only qualified personnel of electrical and mechanical engineering should work with the product.

Use the product correctly after thoroughly reading the section "Safety precautions." In addition, be sure to observe the contents described in warning, caution, and note in this manual.

The product described in this manual is designed and manufactured to be incorporated in general industrial equipment. Do not use it for any other purpose. Oriental Motor Co., Ltd. is not responsible for any compensation for damage caused through failure to observe this warning.





■ Related operating manuals

An operating manual is not included with the product. Download them from Oriental Motor Website Download Page or contact your nearest Oriental Motor sales office. For details on connections and operations, refer to the operating manual of the driver.

- **BLS** Series Motor OPERATING MANUAL (this document)
- **BLS** Series Driver OPERATING MANUAL

2 Safety precautions

The precautions described below are intended to ensure the safe and proper use of the product and to prevent the user and other personnel from exposure to the risk of injury. Use the product only after carefully reading and fully understanding these instructions.

 WARNING	Handling the product without observing the instructions that accompany a "WARNING" symbol may result in serious injury or death.
 CAUTION	Handling the product without observing the instructions that accompany a "CAUTION" symbol may result in injury or property damage.
 Note	The items under this heading contain important handling instructions that the user should observe to ensure safe use of the product.
 memo	The items under this heading contain related information and contents to gain a further understanding of the text in this manual.

WARNING

General

- Assign qualified personnel to the task of installing, wiring, operating/controlling, inspecting, and troubleshooting the product.
Handling by unqualified personnel may result in fire, injury, or damage to equipment.
- Do not use the product in explosive or corrosive environments, in the presence of flammable gases, in areas subjected to splashing water, or near combustible materials.
Doing so may result in fire or injury.
- Do not transport, install, connect, or inspect the product while the power is supplied. Always turn off the power before carrying out these operations.
This may result in damage to equipment.
- Do not use a motor in a vertical drive such as elevating equipment. If the driver protective function is activated, the motor will stop and the moving part may fall, thereby causing injury or damage to equipment.

Installation

- Install the motor in an enclosure. Failure to do so may result in injury.

Connection

- Do not machine or modify the cable. Doing so may result in fire or damage to equipment.
- Do not forcibly bend, pull, or pinch the cable. Doing so may result in fire or damage to equipment.

Operation

- Use a motor (gearhead) and driver only in the specified combination. An incorrect combination may cause fire or damage to equipment.

Maintenance and inspection

- Do not touch the motor or driver when conducting the insulation resistance measurement or dielectric strength test.
Accidental contact may result in electric shock.
- Always turn off the power before performing maintenance or inspection. Failure to do so may result in electric shock.

Repair, disassembly, and modification

- Do not disassemble or modify the motor. Doing so may result in injury or damage to equipment. Refer all such internal inspections and repairs to the sales office from which you purchased the product.

CAUTION

General

- Do not use the motor beyond the specifications. Doing so may result in fire, injury, or damage to equipment.
- Do not touch the motor during operation or immediately after stopping. The surface of the motor is hot and it may cause a skin burn(s).

Installation

- Do not leave anything around the motor that would obstruct ventilation. Doing so may result in damage to equipment.
- Securely install the motor on the mounting plate. Inappropriate installation may cause the motor to detach and fall, resulting in injury or damage to equipment.
- Do not lift the motor by holding the output shaft or the cable. Doing so may result in injury.
- Do not touch the motor output shaft (shaft end or pinion section) with bare hands. Doing so may result in injury.
- When assembling the motor (pinion shaft) with the gearhead, exercise caution not to pinch your fingers or other parts of your body between the motor and gearhead. This may cause injury.
- When installing the motor in equipment, exercise caution not to pinch your fingers or other parts of your body between the product and equipment. This may cause injury.
- Provide a cover over the rotating part (output shaft). Failure to do so may result in injury.
- Securely install a load on the output shaft. Failure to do so may result in injury.

Connection

- Be sure to ground the motor and the driver to prevent damage from static electricity. Failure to do so may result in fire or damage to equipment.

Operation

- Do not touch the rotating part (output shaft) during operation. Doing so may result in injury.
- The motor surface temperature may exceed 70 °C (158 °F) even under normal operating conditions. If the operator is allowed to approach the operating motor, attach a warning label on a conspicuous position as shown in the figure. The surface is hot, and this may cause a skin burn(s).



Warning label

3 Precautions for use

This chapter explains restrictions and requirements that the user should consider when using the product. Use a motor and gearhead only in the specified combination.

■ Combination of motors and gearheads

Combine a motor and a gearhead with the same type of pinion.

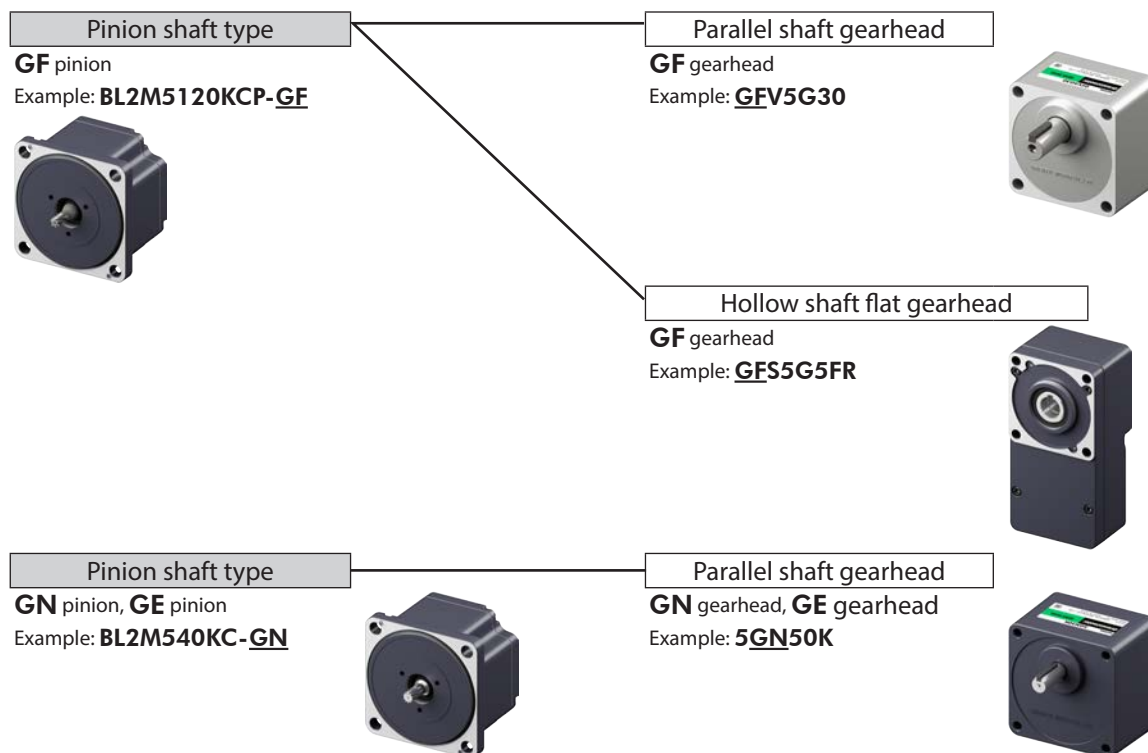

■ Connecting a motor and a driver

Use a connection cable (sold separately) when extending the wiring distance between the motor and the driver. The maximum extension distance including the length of the motor cable should be 10.5 m (34.4 ft.).

■ Grease measures

On rare occasions, grease may ooze out from the gearhead. If there is concern over possible environmental contamination resulting from the leakage of grease, check for grease stains during regular inspections. Alternatively, install an oil pan or other device to prevent damage resulting from contamination. Oil leakage may lead to problems in the customer's equipment or products.

■ Apply grease to the hollow output shaft of a hollow shaft flat gearheads.

For the hollow shaft flat gearheads, apply grease (molybdenum disulfide grease, etc.) to the surface of the load shaft and the inner walls of the hollow output shaft to prevent seizure.

■ When using in low temperature environment

When the ambient temperature is low, the load torque may increase due to the oil seal or the viscosity of the grease used in the gearhead, and the output torque may decrease or the overload alarm may be generated. However, as time passes, the oil seal or grease is warmed up, and the motor can be operated without generating the overload alarm.

■ **Rotation direction of the gearhead output shaft**

The rotation direction of the gearhead output shaft may differ from that of the motor output shaft depending on the gear ratio of the gearhead.

The rotation direction of the motor output shaft is the direction as viewed from the motor output shaft side.

Check the operating manual of the driver for the rotation direction of the motor output shaft relative to the operation input signals of the driver.

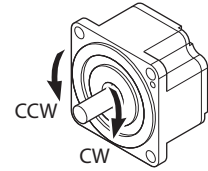

● **Motor and parallel shaft gearhead (GF)**

Gear ratio	Rotation direction of the gearhead output shaft
5, 10, 15, 20, 200	Same direction as the motor output shaft
30, 50, 100	Opposite direction to the motor output shaft

● **Motor and parallel shaft gearhead (GN)**

Gear ratio	Rotation direction of the gearhead output shaft
3, 3.6, 5, 6, 7.5, 9, 12.5, 15, 18, 50, 60, 75, 90, 100, 120, 150, 180	Same direction as the motor output shaft
25, 30, 36	Opposite direction to the motor output shaft

When a decimal gearhead is connected to the gearheads listed above, the rotation speed will be one-tenth. The rotation direction is the same.

● **Motor and parallel shaft gearhead (GE)**

Gear ratio	Rotation direction of the gearhead output shaft
3, 3.6, 5, 6, 7.5, 9, 25, 30, 36, 50, 60	Same direction as the motor output shaft
12.5, 15, 18, 75, 90, 100, 120, 150, 180	Opposite direction to the motor output shaft

When a decimal gearhead is connected to the gearheads listed above, the rotation speed will be one-tenth. The rotation direction is the same.

● **Motor and hollow shaft flat gearhead**

The rotation directions of the gearhead output shaft relative to the motor output shaft are as shown in the figures below.

Motor output shaft	Gearhead output shaft	
	Front	Rear

4 Preparation

This chapter explains the items you should prepare and the name and function of each part.

4.1 Checking the product

Verify that the items listed below are included.

Report any missing or damaged items to the sales office from which you purchased the product.

Verify the model name of the purchased product against the model shown on the name plate of the product.

■ Motor

- Motor 1 unit
- Instructions and Precautions for Safe Use 1 copy

■ Gearhead (Sold separately)

● Parallel shaft gearhead (GF)

- Gearhead 1 unit
- Mounting screw 1 set
(hexagonal socket head screw, flat washer, spring washer: each 4 pieces, parallel key: 1 piece)
- Motor assembling screw 1 set (hexagonal socket head screw: 2 pieces)

● Parallel shaft gearhead (GN, GE)

- Gearhead 1 unit
- Mounting screw 1 set
(screw, flat washer, nut: each 4 pieces, parallel key: 1 piece)

● Hollow shaft flat gearhead

- Gearhead 1 unit
- Mounting screw 1 set
(hexagonal socket head screw, flat washer, spring washer, nut: each 4 pieces, parallel key: 1 piece)
- Safety cover 1 set
(safety cover: 1 piece, mounting screw for safety cover: 2 pieces)
- Motor assembling screw 1 set (hexagonal socket head screw: 4 pieces)

4.2 Model

Verify the model name of the purchased product against the model shown on the name plate of the product.

Tell us the model name, product serial number, and manufacturing date when you contact us.

The box (□) in the model name indicates a number representing the gear ratio.

■ Motor, parallel shaft gearhead (GF)

Output power	Motor model	Gearhead model
30 W	BL2M230KCP-GF	GFV2G□
60 W	BL2M460KCP-GF	GFV4G□
120 W	BL2M5120KCP-GF	GFV5G□

■ Motor, parallel shaft gearhead (GN, GE)

Output power	Motor model	Gearhead model*
25 W	BL2M425KC-GN	4GN□K
40 W	BL2M540KC-GN	5GN□K
90 W	BL2M590KC-GE	5GE□S

* A decimal gearhead with gear ratio of 10:1 can be assembled.
Enter **10X** in the box (□) for the model name of the decimal gearhead.

■ Motor, hollow shaft flat gearhead

Output power	Motor model	Gearhead model
30 W	BL2M230KCP-GF	GFS2G□FR
60 W	BL2M460KCP-GF	GFS4G□FR
120 W	BL2M5120KCP-GF	GFS5G□FR

■ Motor (Round shaft type)

Output power	Model
30 W	BL2M230KCP-A
60 W	BL2M460KCP-A
120 W	BL2M5120KCP-A

4.3 Information about nameplate

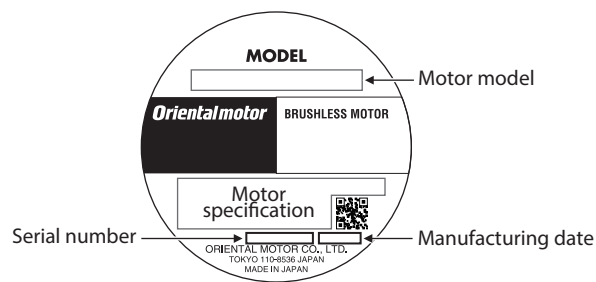

4.4 Driver that can be combined

The driver shown in the table below can be combined with the motors.

■ BLS Series

Output power	Motor model	Driver model
25 W	BL2M425KC-GN	BLSD-K BLSD-KR
30 W	BL2M230KCP-GF BL2M230KCP-A	
40 W	BL2M540KC-GN	
60 W	BL2M460KCP-GF BL2M460KCP-A	
90 W	BL2M590KC-GE	
120 W	BL2M5120KCP-GF BL2M5120KCP-A	

4.5 Names of parts

The figure shows that when a motor and a parallel shaft gearhead (**GF**) are assembled.

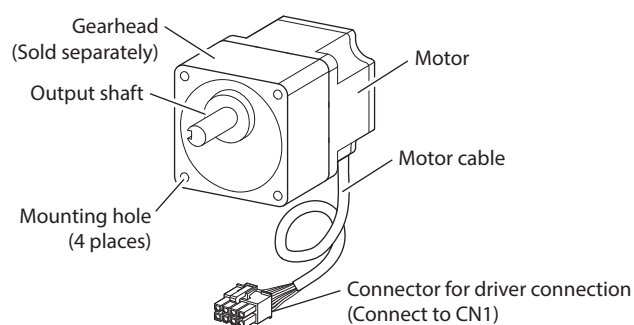

5 Installation

This section explains the installation method of a load in addition to the installation location and installation method of the product.

5.1 Installation location

Install the product in a well-ventilated location that provides easy access for inspection. Install it on an appropriate flat plate with excellent vibration resistance and heat conductivity. The location must also satisfy the following conditions:

[Common conditions]

- Operating ambient temperature 0 to +40 °C [+32 to 104 °F] (non-freezing)
- Operating ambient humidity: 85 % or less (non-condensing)
- Area free of explosive atmosphere, toxic gas (such as sulfuric gas), or liquid
- Area not exposed to direct sun
- Area free of excessive amount of dust, iron particles or the like
- Area free of excessive salt
- Area not subject to continuous vibration or excessive shocks
- Area free of excessive electromagnetic noise (from welders, power machinery, etc.)
- Area free of radioactive materials, magnetic fields, or vacuum
- Altitude: Up to 1000 m (3300 ft.) above sea level

[Degree of protection IP65 products] Motor with parallel shaft gearhead (**GF**) or hollow shaft flat gearhead, round shaft type

- Indoors
- Area not subject to oil (oil droplets) or chemicals

The motor (motor/gearhead) can be used in an environment where it is splashed with water (excluding the connector for driver connection and the mounting surface of the round shaft type).

However, do not use it under water or in high water pressure.

[Degree of protection IP40 products] Motor with parallel shaft gearhead (**GN, GE**)

- Inside an enclosure installed indoors (provide a ventilation hole)
- Area not subject to splashing water (rain, water droplets), oil (oil droplets), or other liquids

5.2 Installation method

■ Motor and parallel shaft gearhead

Assembling a motor and a gearhead

1. Keep the pilot sections of the motor and gearhead in parallel, and assemble the gearhead with the motor while slowly rotating it clockwise/counterclockwise.
At this time, note so that the pinion of the motor output shaft does not hit the side panel or gears of the gearhead strongly.

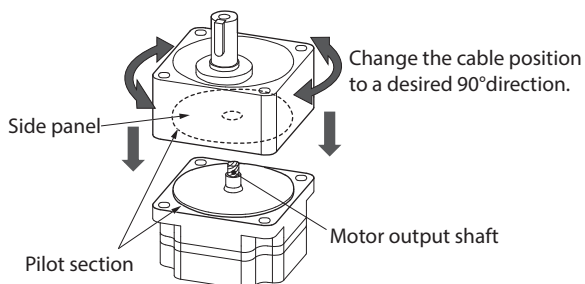

Assemble the gearhead to the motor in a condition where the motor output shaft is in an upward direction.

2. Check that there is no gap between the motor and the gearhead and secure by tightening the hexagonal socket head screw (2 places)*.
- * Only the gearheads (**GF**) are available. The gearheads (**GN, GE**) cannot be secured with screws.

Gearhead model	Screw size	Tightening torque [N·m (lb-in)]
GFV2G □	M2.6	0.4 (3.5)
GFV4G □		
GFV5G □	M3	0.6 (5.3)

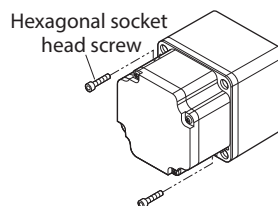

The box (□) in the gearhead model indicates a number representing the gear ratio.

Note

- Do not forcibly assemble the motor and gearhead. Also, do not allow metal objects or foreign substances to enter the gearhead. The pinion of the motor output shaft or gear may be damaged, resulting in noise or reduction in service life.
- Do not allow dust to attach to the pilot sections of the motor and gearhead. Also, be careful not to pinch the O-ring on the motor pilot section. If the O-ring is crushed or severed, grease may leak from the gearhead.

Installing to equipment

Secure the motor and gearhead through four mounting holes using the included mounting screws. Install so that there is no gap between the product and the mounting plate. When using a decimal gearhead, use the screws included with the decimal gearhead.

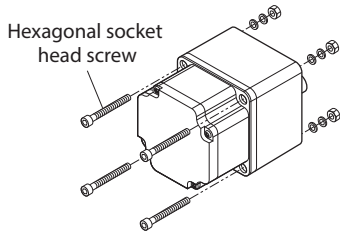

● **Parallel shaft gearhead**

Gearhead model	□: Gear ratio	Mounting screw (included)*			Tightening torque [N·m (lb-in)]
		Screw size	L1 [mm (in.)]	L2 [mm (in.)]	
GFV2G□	5 to 20	M4	50 (1.97)	6 (0.24)	1.4 (12.3)
	30 to 100		55 (2.17)	7 (0.28)	
	200		60 (2.36)	7 (0.28)	
GFV4G□	5 to 20	M6	60 (2.36)	8 (0.31)	5.0 (44)
	30 to 100		65 (2.56)	8 (0.31)	
	200		70 (2.76)	8 (0.31)	
GFV5G□	5 to 20	M8	70 (2.76)	11.5 (0.45)	12.0 (106)
	30 to 100		85 (3.35)	13.5 (0.53)	
	200		90 (3.54)	12.5 (0.49)	
4GN□K	3 to 18	M5	50 (1.97)	10 (0.39)	3.8 (33)
	25 to 180		65 (2.56)	15 (0.59)	
5GN□K	3 to 18	M6	65 (2.56)	14 (0.55)	6.4 (56)
	25 to 180		80 (3.15)	11 (0.43)	
5GE□S	3 to 180		95 (3.74)	21 (0.83)	

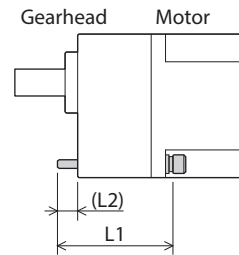

* hexagonal socket head screw or cross recessed pan head machine screw

● **Decimal gearhead**

The table below shows the dimensions of the screws included with the decimal gearheads.

Model	Combined gearhead		Screw size	L1 [mm (in.)]	L2 [mm (in.)]
	Model	□: Gear ratio			
4GN10XK	4GN□K	3 to 18	M5	95 (3.74)	23 (0.91)
		25 to 180			13 (0.51)
5GN10XK	5GN□K	3 to 18	M6	120 (4.72)	32 (1.26)
		25 to 180			14 (0.55)
5GE10XS	5GE□S	3 to 180		140 (5.51)	26 (1.02)

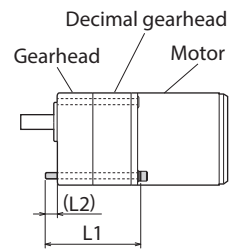

■ Motor (Round shaft type)

Secure the four mounting holes of the motor using hexagonal socket head screws (not included).

Install so that there is no gap between the motor and the mounting plate.

Model	Screw size	Tightening torque [N·m (lb-in)]
BL2M230KCP-A	M4	1.8 (15.9)
BL2M460KCP-A	M6	6.4 (56)
BL2M5120KCP-A	M8	15.5 (137)

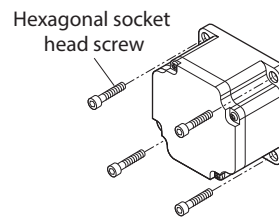

Install the motor on a mounting plate of the following size or larger so that the motor case temperature does not exceed 90 °C (194 °F).

Model	Size of the mounting plate [mm (in.)]	Thickness [mm (in.)]	Material
BL2M230KCP-A	115×115 (4.53×4.53)	5 (0.20)	Aluminum alloy
BL2M460KCP-A	135×135 (5.31×5.31)		
BL2M5120KCP-A	200×200 (7.87×7.87)		

Note Do not install the motor to the mounting hole diagonally or assemble the motor forcibly. Doing so may cause damage to the flange pilot section, thereby resulting in damage to the motor.

■ Motor and hollow shaft flat gearhead

Assembling a motor and a gearhead

1. Keep the pilot sections of the motor and gearhead in parallel, and assemble the gearhead with the motor while slowly rotating it clockwise/ counterclockwise.
At this time, note so that the pinion of the motor output shaft does not hit the side panel or gears of the gearhead strongly.

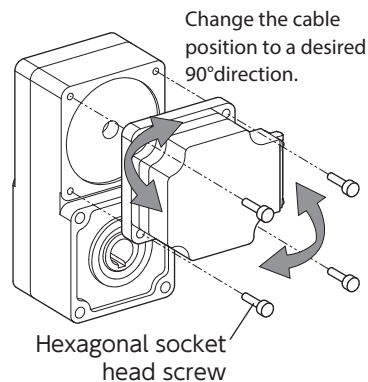

2. Check that there is no gap between the motor and the gearhead and secure by tightening using the hexagonal socket head screw (4 pieces) included with the gearhead.

Gearhead model	Screw size	Tightening torque [N·m (lb-in)]
GFS2G□FR	M4	1.8 (15.9)
GFS4G□FR	M6	6.4 (56)
GFS5G□FR	M8	15.5 (137)

The box (□) in the gearhead model indicates a number representing the gear ratio.

- Note**
- Do not forcibly assemble the motor and gearhead. Also, do not allow metal objects or foreign substances to enter the gearhead. The pinion of the motor output shaft or gear may be damaged, resulting in noise or reduction in service life.
 - Do not allow dust to attach to the pilot sections of the motor and gearhead. Also, be careful not to pinch the O-ring on the motor pilot section. If the O-ring is crushed or severed, grease may leak from the gearhead.

Installing to equipment

A hollow shaft flat gearhead can be installed by using either the front or rear face as the mounting surface. Use the four mounting holes to secure the product with the mounting screw set (included with the gearhead) so that there is no gap between the product and the mounting plate to be installed. Also, attach the included safety cover to the hollow output shaft on the end opposite from the one where the load shaft is installed.

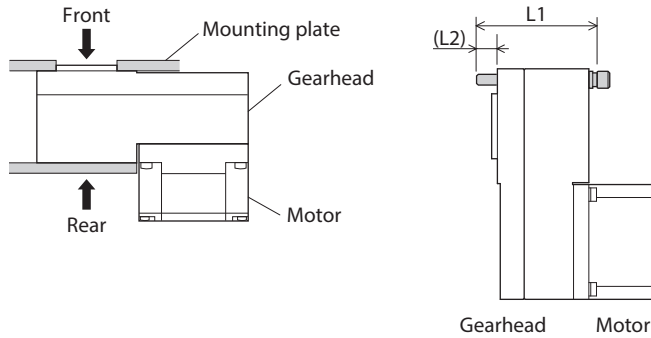

Gearhead model	hexagonal socket head screw (included)			Tightening torque [N·m (lb-in)]
	Screw size	L1 [mm (in.)]	L2 [mm (in.)]	
GFS2G□FR	M5	65 (2.56)	15 (0.59)	3.8 (33)
GFS4G□FR	M6	70 (2.76)	14 (0.55)	6.4 (56)
GFS5G□FR	M8	90 (3.54)	21 (0.83)	15.5 (137)

The box (□) in the gearhead model indicates a number representing the gear ratio.

● **Using the front face as the mounting surface**

When the gearhead is installed by using the front face as the mounting surface, use the mounting boss of the output shaft to align the center.

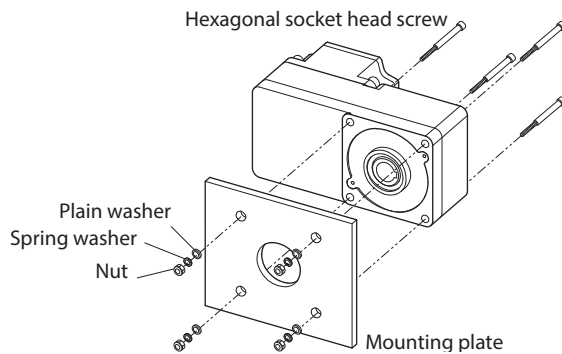

● **Using the rear face as the mounting surface**

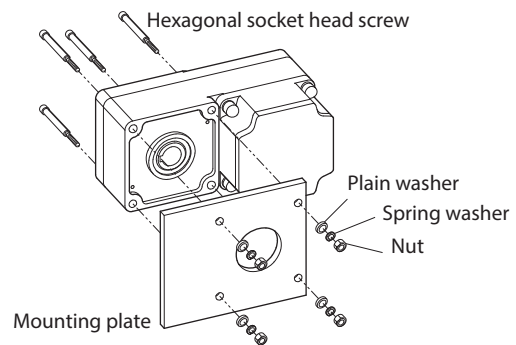

● **Attaching the safety cover**

After installing a load, attach the included safety cover. The safety cover can be attached on either side. Tightening torque: 0.45 N·m (3.9 lb-in)

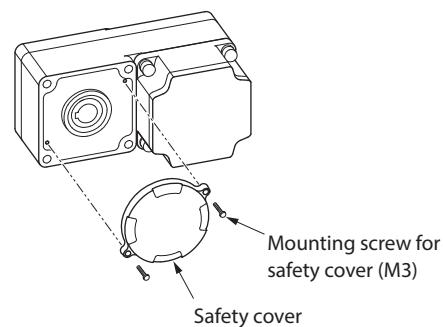

5.3 Installing a load

When installing a load, align the centers of the output shaft and load.

- Note**
- When installing a load, pay attention to centering, belt tension, parallelism of pulleys, etc. Also, firmly secure the tightening screws of the coupling or pulleys.
 - When installing a load, do not damage the output shaft or the bearings. Forcibly inserting the load by driving it with a hammer may damage the bearing. Do not apply any excessive force to the output shaft.
 - Do not modify or machine the output shaft. This may damage the bearing, resulting in damage to the motor and gearhead.

■ Motor and parallel shaft gearhead

● Output shaft shape

Parallel shaft gearhead

A key slot is provided on the output shaft of the gearhead. Make a key slot on the load side, and secure the load using the included parallel key.

● How to install a load

Using a coupling

Align the centers of the output shaft and load shaft in a straight line.

Using a belt

Align the output shaft and load shaft in parallel with each other, and position both pulleys so that the line connecting their centers is at a right angle to the shafts.

Using a gear drive

Align the output shaft and gear shaft in parallel with each other, and let the gears mesh at the center of the tooth widths.

When using the output shaft end tapped hole of a gearhead (GF* and GE gearheads only)

Use a tapped hole provided at the end of the output shaft as an auxiliary means for preventing the transfer mechanism from disengaging.

The box (□) in the gearhead model indicates a number representing the gear ratio.

* Excluding GFV2G□

Gearhead model	Output shaft end tapped hole
GFV4G□	M5, Effective depth 10 mm (0.39 in)
GFV5G□	M6, Effective depth 12 mm (0.47 in)
5GE□S	M5, Effective depth 10 mm (0.39 in)

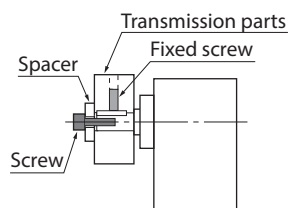

Example of use for output shaft end tapped hole

Motor and hollow shaft flat gearhead

If a large impact occurs at instantaneous stop or a large radial load is applied, use a stepped load shaft.

Note Apply grease (molybdenum disulfide grease, etc.) on the surface of the load shaft and inner walls of the hollow output shaft to prevent seizure.

Stepped load shaft

Secure the retaining ring for hole to the load shaft by tightening the hexagonal socket head screw over a spacer, flat washer and spring washer.

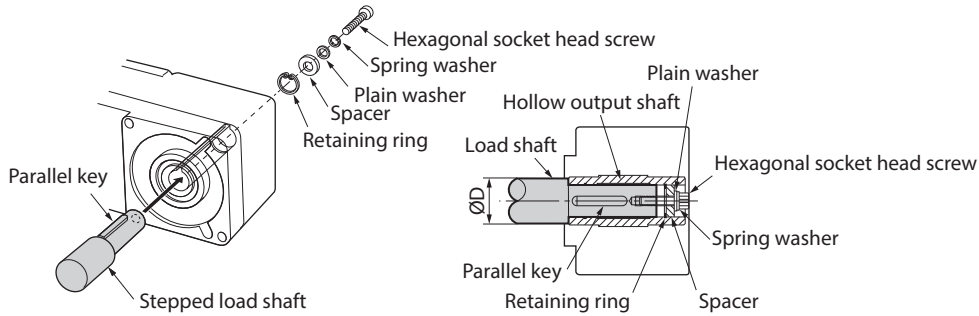

Non-stepped load shaft

Install a spacer on the load shaft side and secure the retaining ring for hole to the load shaft by tightening the hexagonal socket head screw over a spacer, flat washer and spring washer.

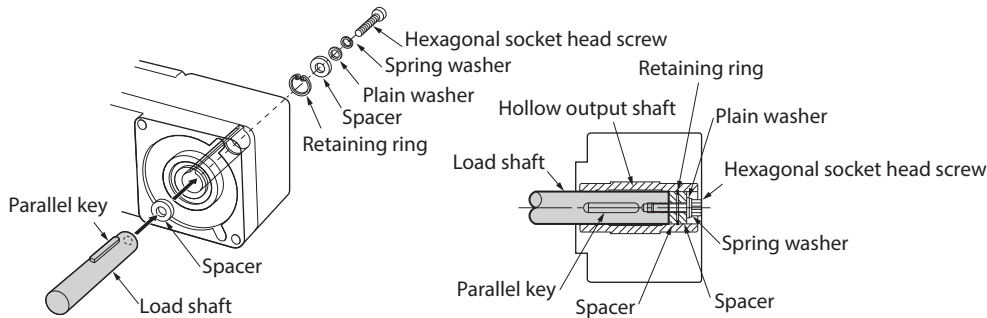

Recommended load shaft installation dimensions [Unit: mm (in.)]

Gearhead model	Inner diameter of hollow shaft (H8)	Recommended diameter of load shaft (h7)	Nominal diameter of retaining ring for hole
GFS2G□FR	$\varnothing 12^{+0.027}_0$ ($\varnothing 0.4724^{+0.0011}$)	$\varnothing 12^{0}_{-0.018}$ ($\varnothing 0.4724^{0}_{-0.0007}$)	$\varnothing 12$ ($\varnothing 0.47$)
GFS4G□FR	$\varnothing 15^{+0.027}_0$ ($\varnothing 0.5906^{+0.0011}$)	$\varnothing 15^{0}_{-0.018}$ ($\varnothing 0.5906^{0}_{-0.0007}$)	$\varnothing 15$ ($\varnothing 0.59$)
GFS5G□FR	$\varnothing 20^{+0.033}_0$ ($\varnothing 0.7874^{+0.0013}$)	$\varnothing 20^{0}_{-0.021}$ ($\varnothing 0.7874^{0}_{-0.0008}$)	$\varnothing 20$ ($\varnothing 0.79$)

Gearhead model	Applicable screw	Spacer thickness	Outer diameter of stepped shaft (ØD)
GFS2G□FR	M4	3 (0.12)	20 (0.79)
GFS4G□FR	M5	4 (0.16)	25 (0.98)
GFS5G□FR	M6	5 (0.20)	30 (1.18)

The box (□) in the gearhead model indicates a number representing the gear ratio.

Motor (Round shaft type)

Use a hexagonal socket set screw (double-point), etc., to secure the load firmly and prevent it from spinning.

5.4 Permissible radial load and permissible axial load

Make sure that the radial load and axial load applied to the output shaft do not exceed the permissible values shown in the table below.

Note Failure due to fatigue may occur when the motor or gearhead bearings and output shaft are repeatedly subjected to a radial load or an axial load that exceeds the permissible limit.

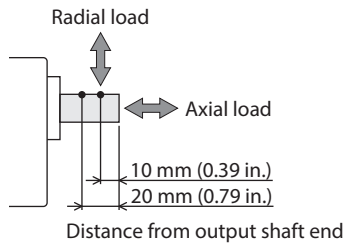

Motor and parallel shaft gearhead (GF)

The values are based on a rated speed of 3000 r/min or less. The values in parentheses () are based on a rated speed of 4000 r/min.

Gearhead model	□: Gear ratio	Permissible radial load [N (lb.)] Distance from output shaft end of the gearhead		Permissible axial load [N (lb.)]
		10 mm (0.39 in.)	20 mm (0.79 in.)	
GFV2G□	5	100 (22) [90 (20)]	150 (33) [110 (24)]	40 (9.0)
	10 to 20	150 (33) [130 (29)]	200 (45) [170 (38)]	
	30 to 200	200 (45) [180 (40)]	300 (67) [230 (51)]	
GFV4G□	5	200 (45) [180 (40)]	250 (56) [220 (49)]	100 (22)
	10 to 20	300 (67) [270 (60)]	350 (78) [330 (74)]	
	30 to 200	450 (101) [420 (94)]	550 (123) [500 (112)]	
GFV5G□	5	300 (67) [230 (51)]	400 (90) [300 (67)]	150 (33)
	10 to 20	400 (90) [370 (83)]	500 (112) [430 (96)]	
	30 to 200	500 (112) [450 (101)]	650 (146) [550 (123)]	

Motor and parallel shaft gearhead (GN, GE)

Gearhead model	□: Gear ratio	Permissible radial load [N (lb.)] Distance from output shaft end of the gearhead		Permissible axial load [N (lb.)]
		10 mm (0.39 in.)	20 mm (0.79 in.)	
4GN□K	3 to 18	100 (22)	150 (33)	50 (11.2)
	25 to 180	200 (45)	300 (67)	
5GN□K	3 to 18	250 (56)	350 (78)	100 (22)
	25 to 180	300 (67)	450 (101)	
5GE□S	3 to 9	400 (90)	500 (112)	150 (33)
	12.5 to 18	450 (101)	600 (135)	
	25 to 180	500 (112)	700 (157)	

■ Motor and hollow shaft flat gearhead

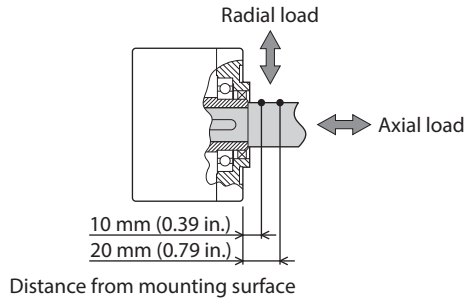

Gearhead model	□: Gear ratio	Permissible radial load [N (lb.)] Distance from gearhead mounting surface		Permissible axial load [N (lb.)]
		10 mm (0.39 in.)	20 mm (0.79 in.)	
GFS2G□FR	5, 10	450 (101) [410 (92)]	370 (83) [330 (74)]	200 (45)
	15 to 200	500 (112) [460 (103)]	400 (90) [370 (83)]	
GFS4G□FR	5, 10	800 (180) [730 (164)]	660 (148) [600 (135)]	400 (90)
	15 to 200	1200 (270) [1100 (240)]	1000 (220) [910 (200)]	
GFS5G□FR	5, 10	900 (200) [820 (184)]	770 (173) [700 (157)]	500 (112)
	15, 20	1300 (290) [1200 (270)]	1110 (240) [1020 (220)]	
	30 to 200	1500 (330) [1400 (310)]	1280 (280) [1200 (270)]	

■ Motor (Round shaft type)

Model	Permissible radial load [N (lb.)] Distance from output shaft end of the motor		Permissible axial load [N (lb.)]
	10 mm (0.39 in.)	20 mm (0.79 in.)	
BL2M230KCP-A	70 (15.7)	100 (22)	15 (3.3)
BL2M460KCP-A	120 (27)	140 (31)	20 (4.5)
BL2M5120KCP-A	160 (36)	170 (38)	25 (5.6)

6 Grounding

■ Notes about wiring

Secure the cable near the connector for driver connection, etc., as shown in the figure, so that no stress is applied to the connector connection part of the cable.

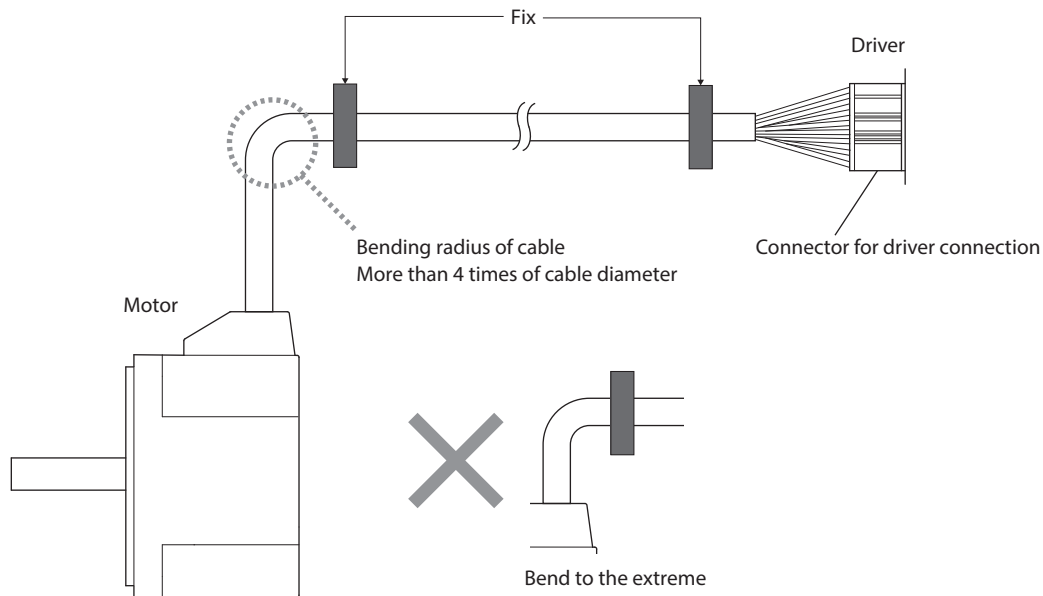

■ Grounding

Ground the motor using one of the four mounting holes on the motor frame shown in the figure.

Ground the motor to the grounding point using the thickest possible wire at the shortest possible distance. Select a large, thick, and uniformly conductive surface for the grounding point.

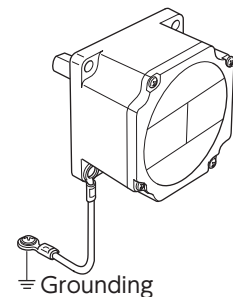

Grounding wire with terminal

- Applicable crimp terminal: Round crimp terminal with insulation cover
- Applicable lead wire: AWG18 to AWG14 (0.75 to 2.0 mm²)
- Screw size: M4
- Tightening torque: 1.2 N·m (10.6 lb-in)

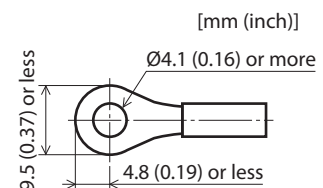

■ Precautions about static electricity

Static electricity may cause the driver to malfunction or be damaged. Be sure to ground the motor and the driver to prevent damage from static electricity.

7 Inspection and maintenance

7.1 Inspection

It is recommended that the following items be inspected periodically after each operation of the motor. If any abnormality occurs, discontinue use of the product and contact your nearest Oriental Motor sales office.



Do not conduct the insulation resistance measurement or dielectric strength test with the motor and driver connected. Doing so may damage the product.

■ Inspection items

- Check to see if any of the mounting screws of the motor and gearhead are loose.
- Check to see if the bearing part (ball bearings) of the motor makes an unusual noise.
- Check to see if the bearing part (ball bearings) or the gear meshing part of the gearhead makes an unusual noise.
- Check to see if the output shaft of the motor and gearhead and a load shaft are out of alignment.
- Check if a damage or stress is applied on the cable or the connection part between the cable and driver is loose.

7.2 Warranty

Check on the Oriental Motor Website for the product warranty.

7.3 Disposal

Dispose the product correctly in accordance with laws and regulations, or instructions of local governments.

8 Specifications

8.1 Specifications

Check on the Oriental Motor Website for the product specifications.

8.2 General specifications

Operating environment	Ambient temperature	0 to +40 °C (+32 to +104 °F) (non-freezing)	
	Ambient humidity	85 % or less (non-condensing)	
	Altitude	Up to 1000 m (3300 ft.) above sea level	
	Surrounding atmosphere	No corrosive gas or dust. No water or oil. Cannot be used in radioactive materials, magnetic field, vacuum or other special environments.	
	Vibration	Not subject to continuous vibration or excessive impact. In conformance with JIS C 60068-2-6 "Sine-wave vibration test method" Frequency range: 10 to 55 Hz Pulsating amplitude: 0.15 mm (0.006 in.) Sweep direction: 3 directions (X, Y, Z) Number of sweeps: 20 times	
Storage environment Shipping environment	Ambient temperature	-25 to +70 °C (-13 to +158 °F) (non-freezing)	
	Ambient humidity	85 % or less (non-condensing)	
	Altitude	Up to 3000 m (10000 ft.) above sea level	
	Surrounding atmosphere	No corrosive gas or dust. No water or oil. Cannot be used in radioactive materials, magnetic field, vacuum or other special environments.	
Degree of protection	IP65	Motor with parallel shaft gearhead (GF) or hollow shaft flat gearhead, Round shaft type (excluding the connector for driver connection and the mounting surface of the round shaft type)	
	IP40	Motor with parallel shaft gearhead (GN, GE) (excluding the connector for driver connection)	

9 Regulations and standards

■ RoHS Directive

This product does not contain the substances exceeding the restriction values.

- Unauthorized reproduction or copying of all or part of this manual is prohibited.
If a new copy is required to replace an original manual that has been damaged or lost, please contact your nearest Oriental Motor sales office.
- Oriental Motor shall not be liable whatsoever for any problems relating to industrial property rights arising from use of any information, circuit, equipment or device provided or referenced in this manual.
- Characteristics, specifications and dimensions are subject to change without notice.
- While we make every effort to offer accurate information in the manual, we welcome your input. Should you find unclear descriptions, errors or omissions, please contact the nearest office.
- **Oriental motor** is a registered trademark or trademark of Oriental Motor Co., Ltd., in Japan and other countries.
Other product names and company names mentioned in this manual may be registered trademarks or trademarks of their respective companies and are hereby acknowledged. The third-party products mentioned in this manual are recommended products, and references to their names shall not be construed as any form of performance guarantee. Oriental Motor is not liable whatsoever for the performance of these third-party products.

© Copyright ORIENTAL MOTOR CO., LTD. 2024

Published in October 2024

- Please contact your nearest Oriental Motor office for further information.

ORIENTAL MOTOR U.S.A. CORP.
Technical Support Tel:800-468-3982
8:30am EST to 5:00pm PST (M-F)

ORIENTAL MOTOR (EUROPA) GmbH
Schiessstraße 44, 40549 Düsseldorf, Germany
Technical Support Tel:00 800/22 55 66 22

ORIENTAL MOTOR (UK) LTD.
Unit 5 Faraday Office Park, Rankine Road,
Basingstoke, Hampshire RG24 8QB UK
Tel:+44-1256347090

ORIENTAL MOTOR (FRANCE) SARL
Tel:+33-1 47 86 97 50

ORIENTAL MOTOR ITALIA s.r.l.
Tel:+39-02-93906347

ORIENTAL MOTOR ASIA PACIFIC PTE. LTD.
Singapore
Tel:1800-842-0280

ORIENTAL MOTOR (MALAYSIA) SDN. BHD.
Tel:1800-806-161

ORIENTAL MOTOR (THAILAND) CO., LTD.
Tel:1800-888-881

ORIENTAL MOTOR (INDIA) PVT. LTD.
Tel:1800-120-1995 (For English)
1800-121-4149 (For Hindi)

TAIWAN ORIENTAL MOTOR CO., LTD.
Tel:0800-060708

SHANGHAI ORIENTAL MOTOR CO., LTD.
Tel:400-820-6516

INA ORIENTAL MOTOR CO., LTD.
Korea
Tel:080-777-2042

ORIENTAL MOTOR CO., LTD.
4-8-1 Higashiueno, Taito-ku, Tokyo
110-8536 Japan
Tel:+81-3-6744-0361
www.orientalmotor.co.jp/ja