

**Servo Motor**

**AZX Series /**

**Motorized Actuator equipped with AZX Series**

**EtherCAT Compatible Driver**

---

**OPERATING MANUAL Hardware Edition**

---

Thank you for purchasing an Oriental Motor product.

This Operating Manual describes product handling procedures and safety precautions.

- Please read it thoroughly to ensure safe operation.
- Always keep the manual where it is readily available.

Original instructions

## Table of contents

<b>1</b>	<b>Introduction .....</b>	<b>3</b>	<b>9</b>	<b>Power removal function .....</b>	<b>30</b>
1-1	Before using the product.....	3	9-1	Safety parameters.....	30
1-2	Related operating manual.....	3	9-2	Notes when using the power removal function.....	31
1-3	How to use operating manuals .....	3	9-3	I/O signals .....	32
<b>2</b>	<b>Overview of the product.....</b>	<b>4</b>	9-4	Operation of power removal function ....	33
<b>3</b>	<b>Safety precautions .....</b>	<b>5</b>	9-5	Example of use.....	35
3-1	Graphical symbols on the driver's front panel.....	6	9-6	Verification testing of power removal function.....	36
3-2	Description of warning.....	7	9-7	Related functions.....	37
<b>4</b>	<b>Precautions for use.....</b>	<b>8</b>	<b>10</b>	<b>Inspection and maintenance .....</b>	<b>40</b>
<b>5</b>	<b>System configuration.....</b>	<b>9</b>	10-1	Inspection.....	40
<b>6</b>	<b>Preparation .....</b>	<b>10</b>	10-2	Warranty.....	40
6-1	Checking the product .....	10	10-3	Disposal.....	40
6-2	How to identify the product model .....	10	<b>11</b>	<b>Cables .....</b>	<b>41</b>
6-3	Products that can be combined.....	10	11-1	Connection cables (For cable type).....	41
6-4	Information about nameplate .....	11	11-2	Connection cables (For connector type).....	44
6-5	Names and functions of parts.....	11	11-3	I/O signal cables .....	45
6-6	Indication of LEDs.....	13	<b>12</b>	<b>Accessories.....</b>	<b>46</b>
<b>7</b>	<b>Installation .....</b>	<b>15</b>	12-1	Relay contact protection parts/circuits.....	46
7-1	Installation location .....	15	12-2	Regeneration resistor .....	46
7-2	Installing the driver.....	15	<b>13</b>	<b>Appendix.....</b>	<b>47</b>
7-3	Installing the regeneration resistor.....	17	13-1	Timing chart .....	47
<b>8</b>	<b>Connection .....</b>	<b>18</b>	13-2	Specifications .....	47
8-1	Connection example .....	18	13-3	Regulations and standards.....	49
8-2	Connecting the control power supply, regeneration resistor, and electromagnetic brake (CN1) .....	19			
8-3	Connecting the main power supply (CN4).....	21			
8-4	Grounding the driver.....	22			
8-5	Connecting the EtherCAT cable (CN5, CN6) .....	23			
8-6	Connecting the USB cable.....	23			
8-7	Connecting the I/O signals (CN7).....	24			
8-8	Noise elimination measures .....	27			
8-9	Compliance with EMC Directive/ Regulations .....	28			

# 1 Introduction

---

## 1-1 Before using the product

Only qualified personnel of electrical and mechanical engineering should work with the product.

Use the product properly after thoroughly reading the section "3 Safety precautions" on p.5. In addition, be sure to observe the contents described in warning, caution, and note in this manual.

The product described in this manual is designed and manufactured to be incorporated in general industrial equipment. Do not use it for any other purpose. Oriental Motor Co., Ltd. is not responsible for any compensation for damage caused through failure to observe this warning.

## 1-2 Related operating manual

For operating manuals, download from Oriental Motor Website Download Page or contact your nearest Oriental Motor sales office.

- **AZX** Series / Motorized Actuator equipped with **AZX** Series EtherCAT Compatible Driver OPERATING MANUAL Hardware Edition (this document)
- **AZX** Series / Motorized Actuator equipped with **AZX** Series EtherCAT Compatible Driver OPERATING MANUAL Software Edition

Read the following operating manuals for a motor or a motorized actuator.

- OPERATING MANUAL Motor Edition
- OPERATING MANUAL Actuator Edition
- Motorized Actuator OPERATING MANUAL Function Setting Edition

## 1-3 How to use operating manuals

To use the product, read both the Hardware Edition (this document) and the Software Edition of the **AZX** Series operating manuals.

The Hardware Edition describes installation, connection, and others.

The Software Edition describes operating methods, control methods via EtherCAT, object list, troubleshooting, and others.

## 2 Overview of the product

---

### ■ How to set parameters

Parameters can be set via EtherCAT or using the support software **MEXE02**.

### ■ Equipped with the power removal function





The power removal function is a function that stops supplying the power to the motor by the hardware. The power removal function is assumed to be used to prevent unexpected starting of the moving parts of equipment when an operator works inside the operating range of the moving parts.

### ■ Providing the ESI File

The ESI (EtherCAT SubDevice Information) file is a file that describes the specific information of the EtherCAT SubDevice products in XML format. By importing the ESI file into the EtherCAT Configuration Tool of a PLC (programmable controller), the settings of EtherCAT can be configured before the driver is delivered. The ESI file can be downloaded from Oriental Motor Website Download Page.



# 3 Safety precautions

The precautions described below are intended to ensure the safe and proper use of the product and to prevent the user and other personnel from exposure to the risk of injury. Use the product only after carefully reading and fully understanding these instructions.

 <b>WARNING</b>	Handling the product without observing the instructions that accompany a "WARNING" symbol may result in serious injury or death.
 <b>CAUTION</b>	Handling the product without observing the instructions that accompany a "CAUTION" symbol may result in injury or property damage.
	The items under this heading contain important handling instructions that the user should observe to ensure safe use of the product.
	The items under this heading contain related information and contents to gain a further understanding of the text in this manual.

## **WARNING**

### General

- Do not use the product in explosive or corrosive environments, in the presence of flammable gases, in areas subject to splashing water, or near combustible materials. Doing so may result in fire, electric shock, or injury.
- Assign qualified personnel to the task of installing, wiring, operating, inspecting, and troubleshooting the product. Handling by unqualified personnel may result in fire, electric shock, injury, or damage to equipment.
- Do not transport, install, connect, or inspect the product while the power is supplied. Doing so may result in electric shock.
- Do not touch the driver while the power is on. Doing so may result in fire or electric shock.
- Do not touch the terminals indicated   signs on the driver's front panel while the power is supplied because high voltage is applied. Doing so may result in fire or electric shock.
- When using the product in a vertical drive application such as elevating equipment, be sure to provide a means of holding the moving part in position. Failure to do so may result in injury or damage to equipment.
- When an alarm of the driver is generated (any of the driver's protective functions is triggered), remove the cause before resetting the alarm (protective function). Continuing the operation without correcting the cause of the problem may cause the motor and driver to malfunction, resulting in injury or damage to equipment.

### Installation

- Install the driver in an enclosure. Failure to do so may result in electric shock or injury.
- Be sure to ground the driver as it is Class I equipment. Failure to do so may result in electric shock.

### Connection

- Keep the input power voltage of the driver within the specified range. Failure to do so may result in fire or electric shock.
- Connect the product securely according to the connection diagram. Failure to do so may result in fire or electric shock.
- Do not forcibly bend, pull, or pinch the cable. Doing so may result in fire or electric shock.

### Operation

- Turn off the main power supply and the control power supply in the event of a power failure. Failure to do so may result in injury or damage to equipment.
- Take safety measures to protect against momentary voltage drops. Failure to do so may cause the motor to stop or reduce the holding force or rotational torque, resulting in injury or damage to equipment.
- Do not remove the motor excitation during operation. Doing so may cause the motor to stop and lose holding torque, resulting in injury or damage to equipment.

### Repair, disassembly, and modification

- Do not disassemble or modify the driver. Doing so may result in injury or damage to equipment.

### Maintenance and inspection

- Do not touch the connection terminals of the driver immediately after turning off the main power supply and the control power supply. Before performing connection or inspection, turn off the main power supply and the control power supply, and check the CHARGE LED has been turned off. Residual voltage may cause electric shock.

**⚠ CAUTION**

**General**

- Do not use the driver beyond the specifications. Doing so may result in electric shock, injury, or damage to equipment.
- Keep your fingers and objects out of the openings in the driver. Failure to do so may result in fire, electric shock, or injury.
- Do not touch the driver during operation or immediately after stopping. The surface is hot, and this may cause a skin burn(s).
- Do not forcibly bend or pull the cable that is connected to the driver. Doing so may cause damage to the product.

**Installation**

- Keep the area around the driver free of combustible materials. Failure to do so may result in fire or a skin burn(s).
- Do not leave anything around the driver that would obstruct ventilation. Doing so may result in damage to equipment.



**Operation**

- Use a motor and driver only in the specified combination. An incorrect combination may cause a fire.
- For the control power supply, use a DC power supply with reinforced insulation on its primary and secondary sides. Failure to do so may result in electric shock.
- Provide an emergency stop device or emergency stop circuit external to the equipment so that the entire system will operate safely in the event of a system failure or malfunction. Failure to do so may result in injury.
- Before turning on the main power supply and the control power supply, turn OFF all input signals to the driver. Failure to do so may result in injury or damage to equipment.
- When moving the moving part by hand, put the motor in a non-excitation state. Continuing to work while the motor is in an excitation state may result in injury.
- When an abnormal condition occurs, immediately stop operation to turn off the main power supply and the control power supply. Failure to do so may result in fire, electric shock, or injury.
- Take measures against static electricity when operating the switches of the driver. Failure to do so may result in the driver malfunction or damage to equipment.

**Inspection and maintenance**

- Do not touch the terminals while conducting the insulation resistance measurement or the dielectric strength test. Accidental contact may result in electric shock.

**3-1 Graphical symbols on the driver's front panel**

	<b>⚠ WARNING</b> This is the Protective Earth Terminal. Be sure to ground because improper grounding may result in electric shock.
	<b>⚠ WARNING</b> A high voltage is applied to the motor connector (CN3) and the main power supply input terminal (CN4). Do not touch them while the power is on. Doing so may result in fire or electric shock.

## 3-2 Description of warning

A warning about handling precautions is described on the driver. Be sure to observe the description contents when handling the product.

### Electrical hazard warning label

<p><b>⚠ WARNING – Risk of electric shock.</b></p>	
⚠	<ul style="list-style-type: none"> <li>• Read manual before installing. (Multiple rated)</li> <li>• Do not touch the driver immediately after the power is cut off, or until the CHARGE LED (lit in red) turns off. Doing so may result in electric shock due to residual voltage.</li> </ul>
<p><b>⚠ AVERTISSEMENT – Risque de décharge électrique.</b></p>	
⚠	<ul style="list-style-type: none"> <li>• Lire le manuel avant l'installation.</li> <li>• Ne pas toucher au variateur immédiatement après la mise hors tension ou avant que la LED "présence de la tension" (Rouge) ne soit éteinte. Le non respect de ces règles pourrait entraîner un choc électrique.</li> </ul>
<p><b>⚠ 警告 – けが・感電のおそれがあります。</b></p>	
⚠	<ul style="list-style-type: none"> <li>• 据え付け、運転の前には必ず取扱説明書をお読み下さい。</li> <li>• 電源を切った直後、CHARGE LED(赤色点灯)が消灯するまでドライバに触れないで下さい。残留電圧により感電の原因になります。</li> </ul>

Material: PET

# 4 Precautions for use

---

This chapter explains restrictions and requirements the user should consider when using the product.

- **Always use Oriental Motor cables to connect a motor and a driver.**

Refer to p.41 for the cable models.

- **When conducting the insulation resistance measurement or the dielectric strength test, be sure to separate the connection between the motor and the driver.**

Conducting the insulation resistance measurement or the dielectric strength test with the motor and driver connected may result in damage to the product.

- **Preventing leakage current**

Stray capacitance exists between the driver's current-carrying line and other current-carrying lines, the earth and the motor, respectively. A high-frequency current may leak out through such capacitance, having a detrimental effect on the surrounding equipment. The actual leakage current depends on the driver's switching frequency, the length of wiring between the driver and motor, and so on. When installing an earth leakage breaker, use a product offering resistance against high frequency current such as the one specified below.

Mitsubishi Electric Corporation: NV series

- **If a vertical drive such as gravitational operation is performed or if sudden start-stop operation of a large inertia is repeated frequently, connect the Oriental Motor regeneration resistor RGB200.**

The factory setting is to use the built-in regeneration resistor. Using the built-in regeneration resistor, however, continuous regeneration operation, vertical drive such as gravitational operation, or sudden start-stop operation of a large inertia cannot be performed. When performing such operation, use the Oriental Motor regeneration resistor **RGB200**. Refer to p.20 for the connection method.

- **Note when connecting a power supply whose positive side is grounded**

The USB connector, CN5, CN6, and CN7 connectors on the driver are not electrically insulated. When grounding the positive terminal of the power supply, do not connect any equipment (PC, etc.) whose negative terminal is grounded. Doing so may cause the driver and this equipment to short, damaging both. When connecting, do not ground equipment.

- **Saving data to the non-volatile memory**

Do not turn off the control power supply while writing the data to the non-volatile memory, and also do not turn off for five seconds after the completion of writing the data. Doing so may abort writing the data and cause an alarm of EEPROM error to generate. The non-volatile memory can be rewritten approximately 100,000 times.

- **Noise elimination measures**

Refer to p.27 for noise elimination measures.



## 5 System configuration

The figure shows an example when the cable type electromagnetic brake motor with three-phase 200 to 240 VAC input is used.

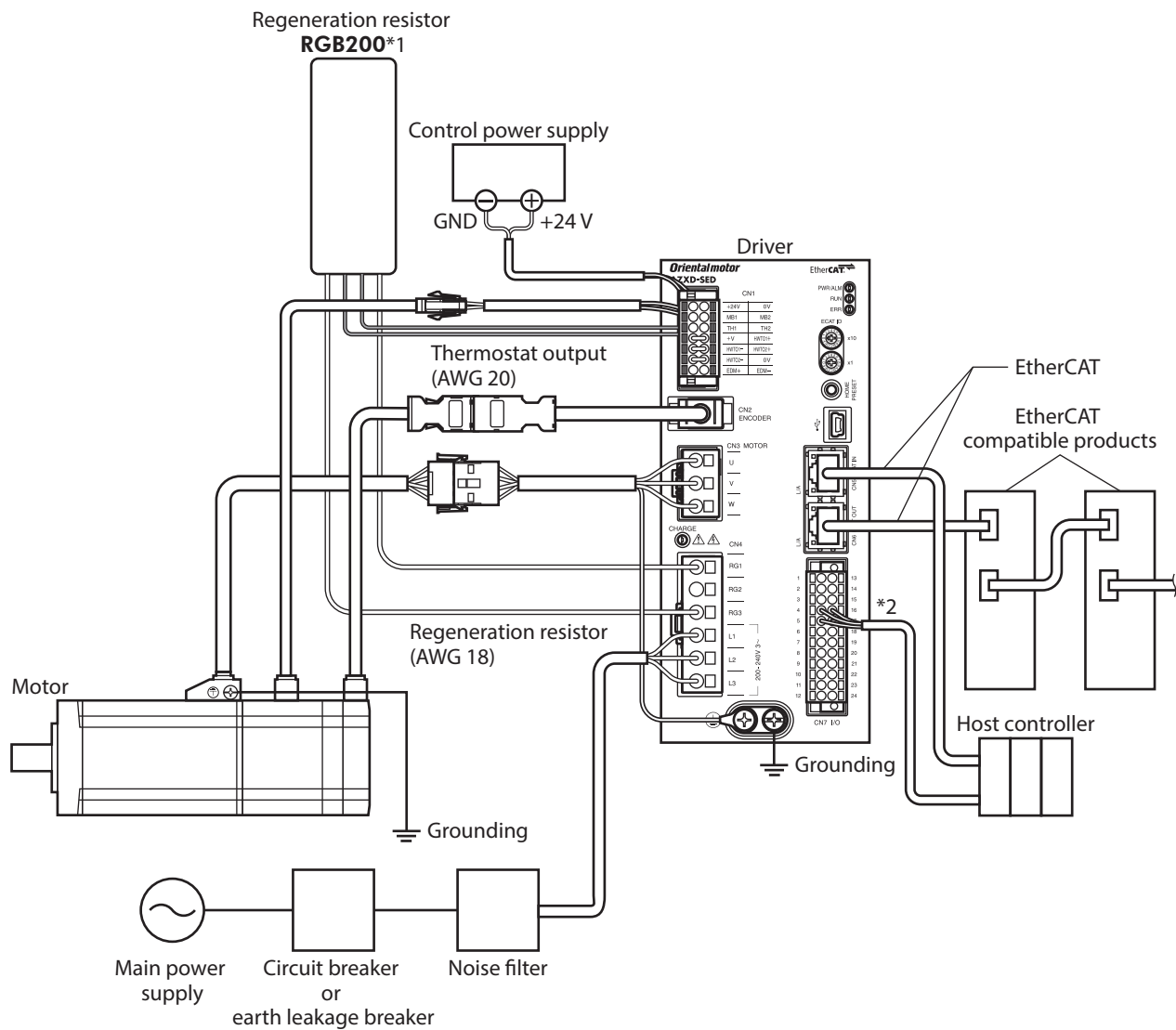

\*1 If a vertical drive such as gravitational operation is performed or if sudden start-stop operation of a large inertia is repeated frequently, connect the regeneration resistor.

\*2 Connect when using direct I/O or sensors.

## 6 Preparation

This chapter explains the items you should check and the names and functions of each part.

### 6-1 Checking the product

Verify that the items listed below are included. Report any missing or damaged items to the Oriental Motor sales office from which you purchased the product.

- Driver ..... 1 unit
- CN1 connector (14 pins) ..... 1 piece
- CN4 connector (6 pins) ..... 1 piece
- CN7 connector (24 pins) ..... 1 piece
- Connector lever ..... 1 piece (for CN4 connector)
- Instructions and Precautions for Safe Use ..... 1 copy

#### Included connector model

Type	Part number	Manufacturer
CN1 connector	DFMC1,5/7-ST-3,5-LR	PHOENIX CONTACT GmbH & Co. KG
CN4 connector	1-2271454-6	TE Connectivity
CN7 connector	DFMC1,5/12-ST-3,5	PHOENIX CONTACT GmbH & Co. KG

### 6-2 How to identify the product model

Check the model name of the driver against that shown on the nameplate. Refer to for how to identify the nameplate p.11.

**AZXD** - **S** **ED**  
 1            2    3

1	Series	<b>AZXD: AZX Series driver</b>
2	Power supply input	<b>S: Three-phase 200-240 VAC</b>
3	Network type	<b>ED: EtherCAT</b>



This driver can also be used with a power supply of single-phase 200-240 VAC.

### 6-3 Products that can be combined

Products with which the driver can be combined are listed below.

For details about the models, refer to the Oriental Motor Website or the brochure of the product to be combined.

Power supply type	Product type	Applicable Series	Model name representing Series name	Example of model name
AC input	Servo motor	<b>AZX Series</b>	<b>AZXM</b>	<b>AZXM640AC</b> <b>AZXM940AC-PS10</b>
	Motorized actuator	<b>DGII Series</b>	<b>DGM</b>	<b>DGM200R18-AZXAC</b>

## 6-4 Information about nameplate

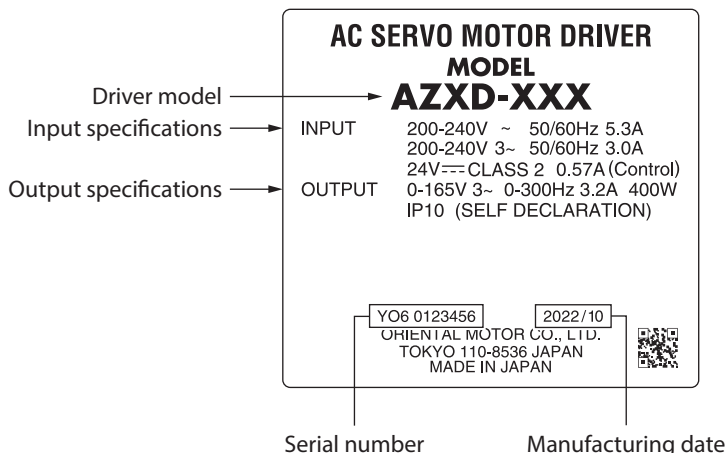

The figure shows an example.

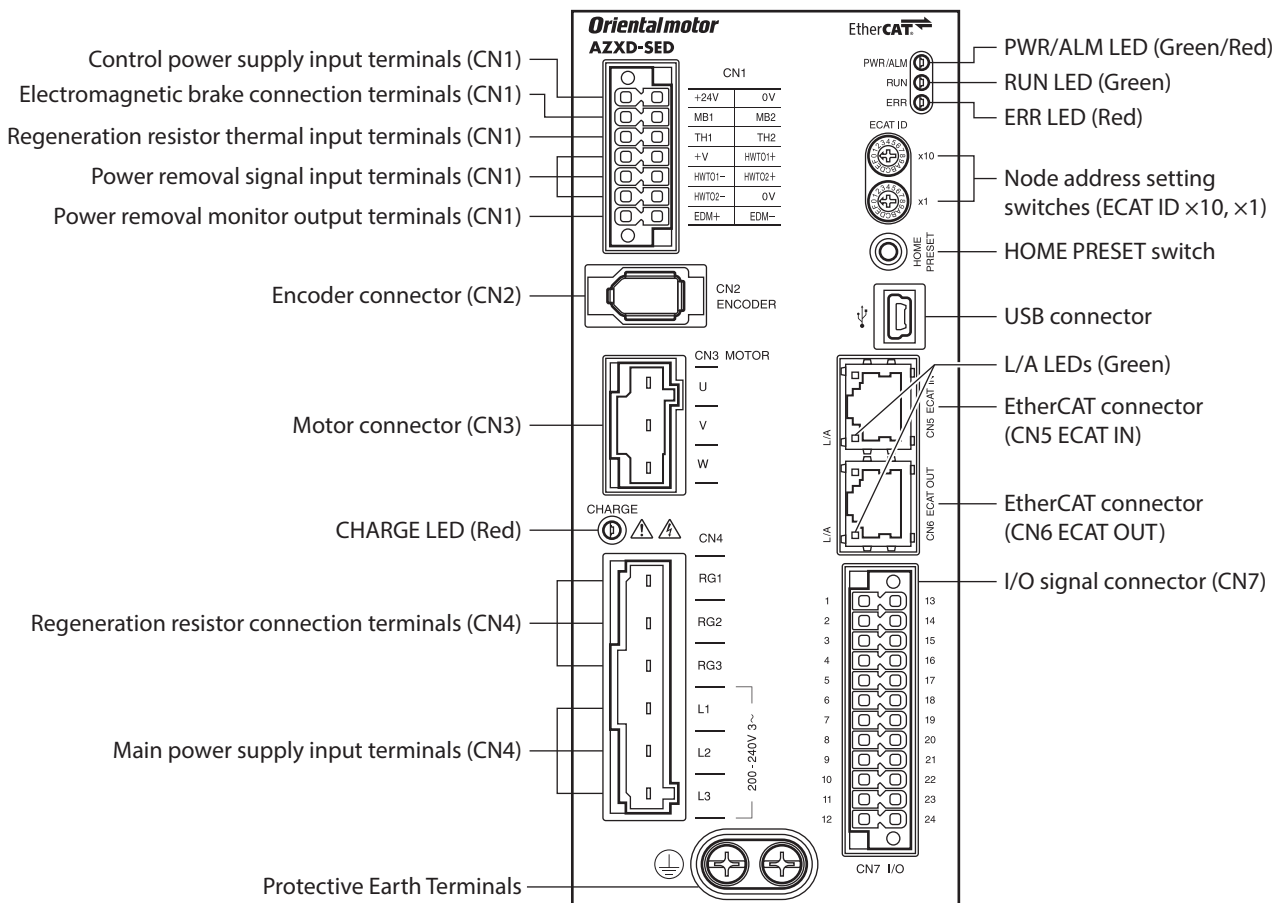

**memo** The position describing the information may vary depending on the product.

## 6-5 Names and functions of parts



Type	Name	Sign	Description
LED	CHARGE LED (Red)	CHARGE	This LED is lit while the main power supply is turned on. After the main power supply is turned off, the LED is turned off once the residual voltage in the driver drops to a safe level.
	PWR/ALM LED (Green/Red)	PWR/ALM	<ul style="list-style-type: none"> <li>This LED is lit in green while the control power supply is turned on.</li> <li>If an alarm (protective function) is generated, the LED will blink in red.</li> <li>If the power removal function (p.30) is triggered, the LED will blink in green.</li> <li>If information is generated, the LED will simultaneously blink in green and red twice. (Green and red colors may overlap and it may be visible to orange.)</li> </ul>
	RUN LED (Green)	RUN	This LED indicates the status of EtherCAT.
	ERR LED (Red)	ERR	This LED blinks when an error occurred via EtherCAT.
	L/A LEDs (Green)	L/A	This LED indicates the LINK/ACT status of EtherCAT.
Switch	Node address setting switches	ECAT ID×10 ECAT ID×1	Sets the node address. Factory setting: 00 (×10: 0, ×1: 0)
	HOME PRESET switch	HOME PRESET	This switch is used to set the starting position (home) when positioning operation is performed.
Connector	Encoder connector (CN2)	ENCODER	Connects the encoder.
	Motor connector (CN3)	MOTOR	Connects the motor.
	USB connector		Connects a PC in which the <b>MEXE02</b> software has been installed. (USB2.0 mini-B port)
	EtherCAT connector (CN5)	ECAT IN	Connects to the EtherCAT compatible product on the host side.
	EtherCAT connector (CN6)	ECAT OUT	Connects to the EtherCAT compatible product of the following node address.
	I/O signal connector (CN7)	I/O	Connects when using direct I/O or sensors.
Terminal	Control power supply input terminals (CN1)	+24 V, 0 V	Connects a control power supply.
	Electromagnetic brake connection terminals (CN1)	MB1, MB2	Connects the lead wires from the cable for electromagnetic brake.
	Regeneration resistor thermal input terminals (CN1)	TH1, TH2	Connects the Oriental Motor regeneration resistor <b>RGB200</b> . If the regeneration resistor <b>RGB200</b> is not connected, short the TH1 and TH2 terminals.
	Power removal signal input terminals (CN1)	HWT01+, HWT01– HWT02+, HWT02–	Connects the external device.
	Power removal monitor output terminals (CN1)	EDM+, EDM–	
	Regeneration resistor connection terminals (CN4)	RG1, RG2, RG3	Connects the Oriental Motor's regeneration resistor <b>RGB200</b> . If the regeneration resistor <b>RGB200</b> is not connected, short the RG2 and RG3 terminals.
	Main power supply input terminals (CN4)	L1, L2, L3	Connects a main power supply.
Protective Earth Terminals		Ground using a grounding wire of AWG 16 to 14 (1.25 to 2.0 mm <sup>2</sup> ).	

## 6-6 Indication of LEDs

### ■ LED indication related to driver status

PWR/ALM LED status		Description
Green	Red	
No light	No light	The control power supply is not turned on.
Light	No light	The control power supply is on.
No light	Blinking	An alarm is being generated. The number of blinking times of LED varies depending on the alarm type. For details about alarms, refer to the <b>AZX</b> Series <u>OPERATING MANUAL Software Edition</u> . The LED is lit in green when the alarm is reset.
Blinking	No light	The power removal function has been activated. After the power removal function is released, the LED is lit in green when the ETO-CLR input is turned ON.
Blinking twice at the same time*		<ul style="list-style-type: none"> <li>Information is being generated. The LED is lit in green when the information is cleared. For details about information, refer to the <b>AZX</b> Series <u>OPERATING MANUAL Software Edition</u>.</li> <li>Remote operation is being executed with the <b>MEXE02</b> software. The LED is lit in green when remote operation is completed.</li> </ul>
Blinking at the same time*		The interlock was released by holding down the HOME PRESET switch. The LED is lit in green when the time set in the Extended input (EXT-IN) interlock releasing duration (4973h) is elapsed.
Lit at the same time*		The input signal assigned to the HOME PRESET switch is being executed. The LED is lit in green when it is completed.
Repeating "Green → Red → Simultaneously lit* → No light"		This is the driver simulation mode.

\* Green and red colors may overlap and it may be visible to orange.

### ■ LED indication related to EtherCAT status

LED indicator	LED status	Description
RUN (Green)	No light	Initialization state
	Blinking*	Pre-Operational state
	Single flash*	Safe-Operational state
	Lit	Operational state (Normal condition)
ERR (Red)	No light	No communication error
	Blinking*	Communication setting error
	Single flash*	Communication data error
	Double flash*	Communication watchdog timeout
L/A (Green)	No light	No link
	Light	Link establishment
	Flickering*	In operation after link establishment

\* The blinking state of the LED is as follows. (Unit: ms)

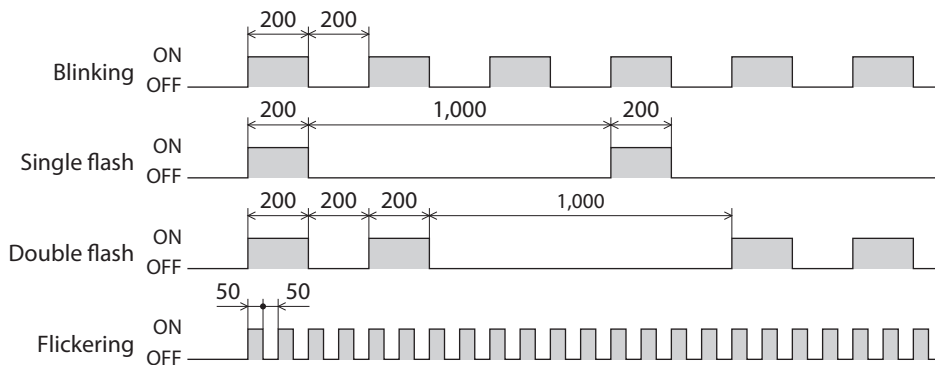

# 7 Installation

This chapter explains the installation location and installation method of the driver.

## 7-1 Installation location

The driver is designed and manufactured to be incorporated in equipment. Install it in a well-ventilated location that provides easy access for inspection. The location must also satisfy the following conditions:

- Inside an enclosure that is installed indoors (provide vent holes)
- Operating ambient temperature  
The operating ambient temperature varies depending on the product combined or the main power supply specifications.

Product model to be combined	Three-phase 200-240 VAC	Single-phase 200-240 VAC
<b>AZXM640</b> <b>AZXM940</b>	0 to +55 °C (+32 to +131 °F) (non-freezing)	
<b>AZXM960</b> <b>AZXM1260</b> <b>DGM200</b>	0 to +55 °C (+32 to +131 °F) (non-freezing)	0 to +50 °C (+32 to +122 °F) (non-freezing)
<b>AZXM1075</b> <b>AZXM1175</b>	0 to +55 °C (+32 to +131 °F) (non-freezing)	0 to +40 °C (+32 to +104 °F) (non-freezing)

- Operating ambient humidity: 85 % or less (non-condensing)
- Area free of explosive atmosphere, toxic gas (such as sulfuric gas), or liquid
- Area not exposed to direct sun
- Area free of excessive amount of dust, iron particles or the like
- Area not subject to splashing water (rain, water droplets), oil (oil droplets) or other liquids
- Area free of excessive salt
- Area not subject to continuous vibration or excessive shocks
- Area free of excessive electromagnetic noise (from welders, power machinery, etc.)
- Area free of radioactive materials, magnetic fields, or vacuum
- Up to 1,000 m (3,300 ft.) above sea level

## 7-2 Installing the driver

The driver is designed so that heat is dissipated via air convection and conduction through the enclosure. Install the driver to a flat metal plate offering high heat conductivity [material: aluminum, 200×200×2 mm (7.87×7.87×0.08 in.) or equivalent]. When installing the driver, allow at least 25 mm (0.98 in.) of horizontal and vertical clearance between the driver and the enclosure or other equipment inside the enclosure.

When installing the driver, use three screws (M4, not included) to secure the mounting hole and the cutouts.



- Install the driver in an enclosure with at least IP54 protection when used in a pollution degree 3 environment.
- Do not install any equipment that generates a large amount of heat or noise near the driver.
- Do not install the driver under a host controller or other heat-sensitive equipment.
- Be sure to install the driver vertically (in vertical position).
- If the ambient temperature of the driver exceeds the upper limit of the operating ambient temperature, reconsider the ventilation condition, such as providing forced cooling by using fans or creating spaces between the drivers. Refer to "7-1 Installation location" for the operating ambient temperature of the driver.

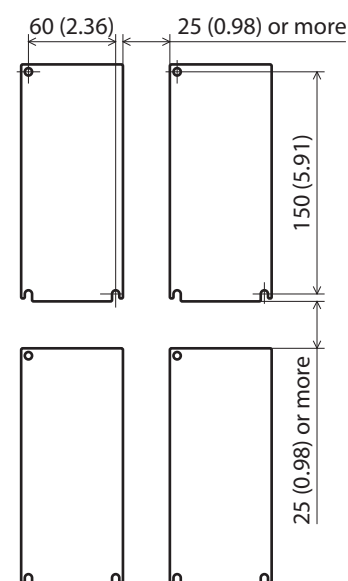

Unit: mm (in.)

● **When closely installing drivers in horizontal direction**

The drivers can be installed closely in the horizontal direction when the following conditions are satisfied.

- Metal plate [material: aluminum, 350×350×2 mm (13.78×13.78×0.08 in.) or equivalent]
- Ambient temperature

The ambient temperature varies depending on the product combined or the main power supply specifications.

Product model to be combined	Three-phase 200-240 VAC	Single-phase 200-240 VAC
<b>AZXM640</b> <b>AZXM940</b>	0 to +45 °C (+32 to +113 °F) (non-freezing)	
<b>AZXM960</b> <b>AZXM1260</b> <b>DGM200</b>	0 to +45 °C (+32 to +113 °F) (non-freezing)	0 to +40 °C (+32 to +104 °F) (non-freezing)
<b>AZXM1075</b> <b>AZXM1175</b>	0 to +45 °C (+32 to +113 °F) (non-freezing)	Close installation is not allowed

Can be installed closely.

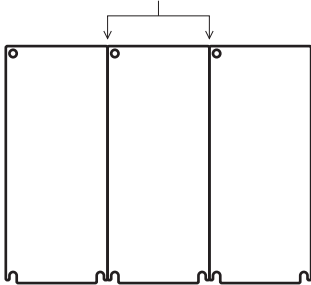

■ **Dimensions [Unit: mm (in.)]**

Mass: 1.5 kg (3.3 lb.)

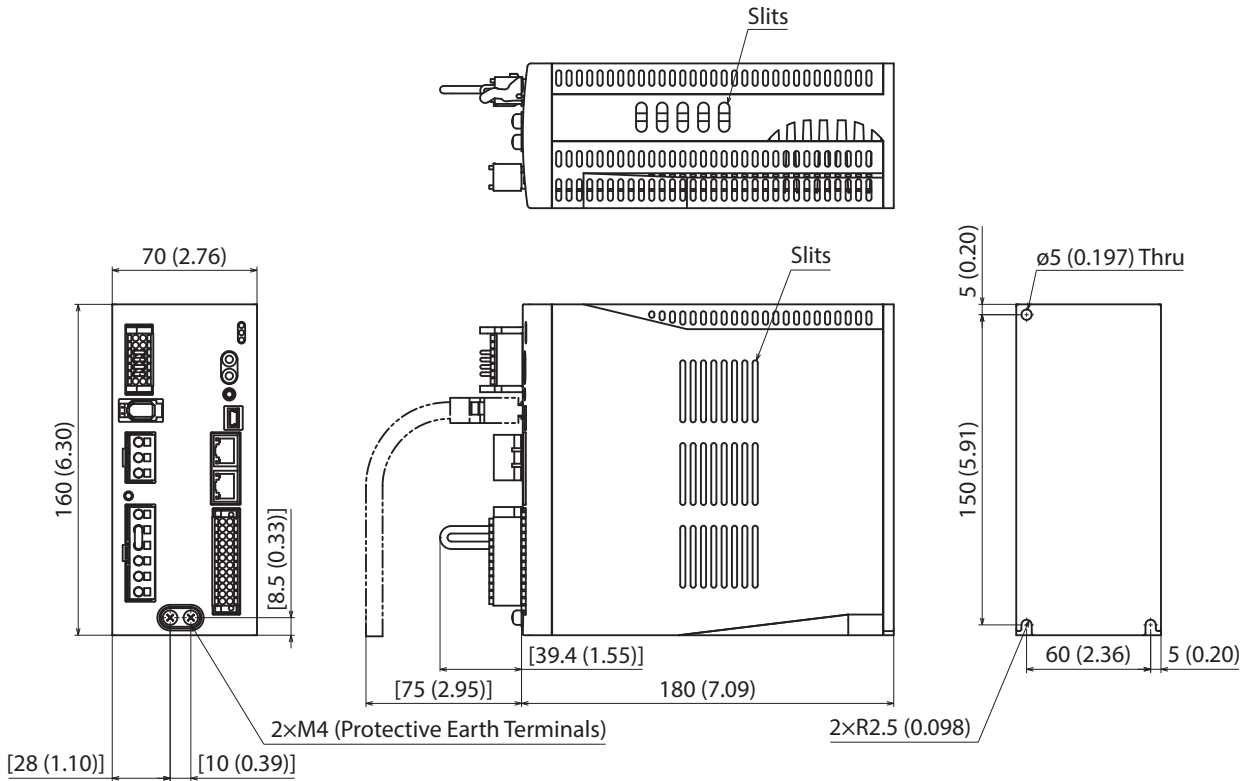



## 7-3 Installing the regeneration resistor

Install the regeneration resistor in a location where heat dissipation capacity equivalent to a level achieved with a heat sink [made of aluminum, 350×350×3 mm (13.78×13.78×0.12 in.)] is ensured.

Use two screws (M4, not included) to secure the regeneration resistor on a smooth metal plate offering high heat conductivity.

After that, install the protection cover using four screws (M4, not included).

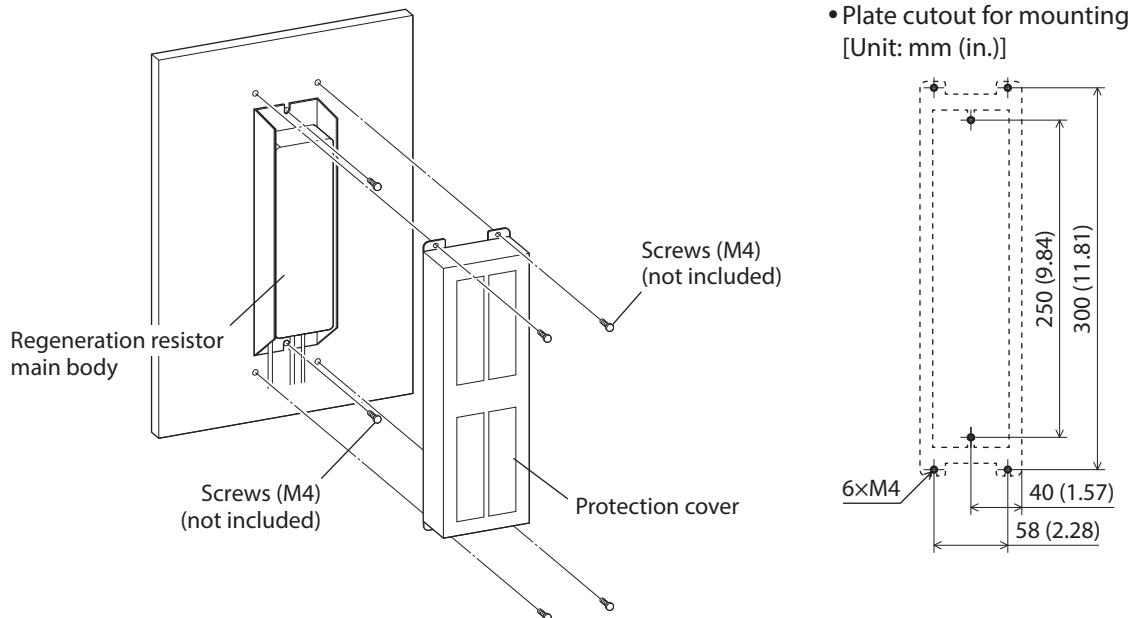

### **⚠ CAUTION**

The regeneration resistor main body will reach a high temperature. Be sure to use it with the protection cover to prevent hands from touching. Failure to do so may result in a skin burn(s).

# 8 Connection

This chapter explains a connection example of a driver and a motor, connection methods of power supplies and the regeneration resistor **RGB200**, grounding method, etc. Noise suppression measures and installation and wiring methods to comply with the EMC Directive/Regulations are also explained.

## ! WARNING

- For protection against electric shock, do not turn on the power supply until the wiring is completed.
- A high voltage is applied to the motor connector (CN3) and the main power supply input terminals (CN4). Do not touch them while the power is on. Doing so may result in fire or electric shock.

### 8-1 Connection example

The figure shows an example when the cable type electromagnetic brake motor with three-phase 200 to 240 VAC input is used.

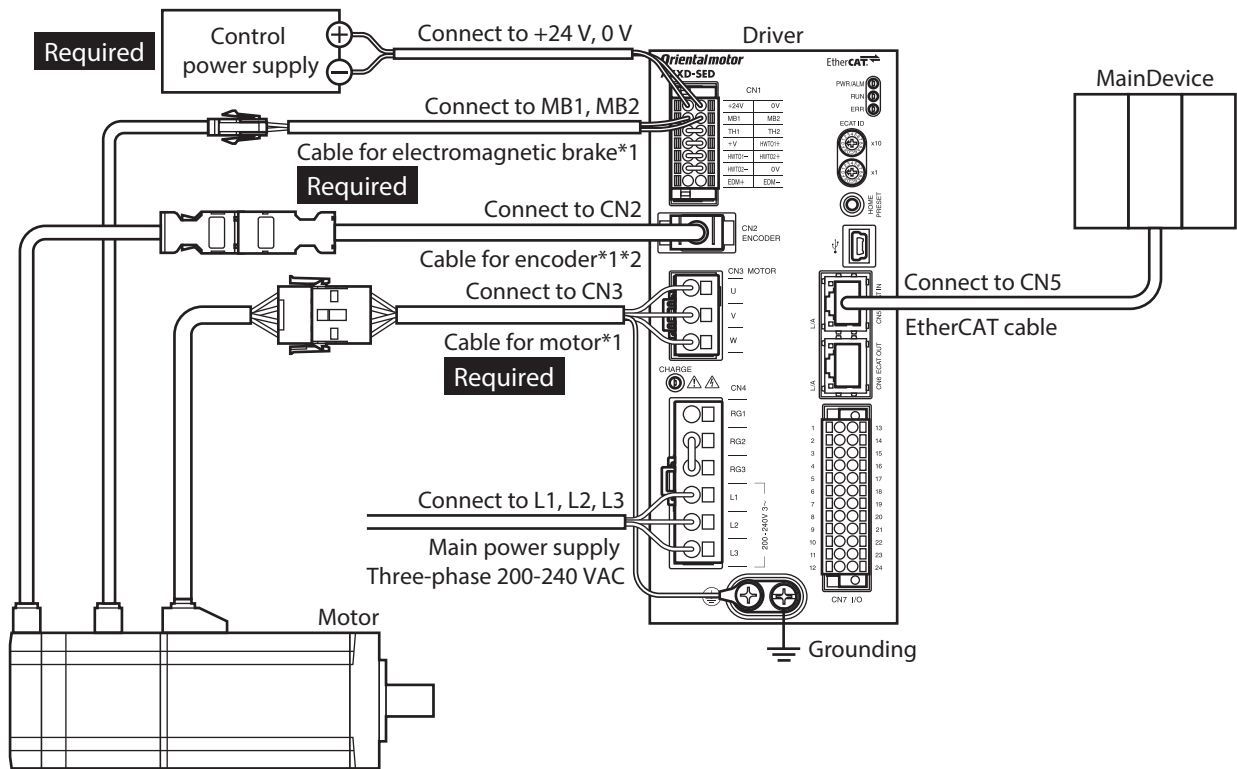

\*1 Purchase is required separately.

\*2 Use the cable for encoder when the length of the encoder cable of motor is not enough.

## Note

- Connect the connectors securely. Insecure connections of the connectors may cause malfunction or damage to the motor or driver.
- Before connecting or disconnecting a connector, turn off the main power supply and the control power supply, and check the CHARGE LED has been turned off. Residual voltage can cause electric shock.
- The lead wires of the cable for electromagnetic brake have polarities, so connect them with the correct polarity. If the lead wires are connected with reversed polarity, the electromagnetic brake will not operate properly.
- Do not wire the power supply cable of the driver in the same cable duct with other power lines or the motor cable. Doing so may cause malfunction due to noise.

**Note** Keep the wiring distance between the motor and the driver equal to or less than the following values. Exceeding the following wiring distance may cause the driver to generate heat or increase the electrical noise emitted from the product.  
 Cable type: 20 m (65.6 ft.)  
 Connector type: 10 m (32.8 ft.)

- memo**
- A control power supply is required with or without an electromagnetic brake. Be sure to connect it.
  - When disconnecting the motor cable, pull out while pressing the latches on the connector with fingers.
  - When installing the motor on a moving part, use flexible cables. Refer to p.41 for the model name.

■ **Electrical wire size**

Connector	Terminal symbol	Recommended wire size
CN1	+24 V, 0 V, MB1, MB2, TH1, TH2, HWTO1+, HWTO1-, HWTO2+, HWTO2-, EDM+, EDM-	Stranded wire or solid wire AWG 24 to 16 (0.2 to 1.25 mm <sup>2</sup> )
CN4	RG1, RG2, RG3, L1, L2, L3	Stranded wire or solid wire AWG 18 to 14 (0.75 to 2.0 mm <sup>2</sup> )
CN7	-	Stranded wire or solid wire AWG 24 to 16 (0.2 to 1.25 mm <sup>2</sup> )

## 8-2 Connecting the control power supply, regeneration resistor, and electromagnetic brake (CN1)

Use the CN1 connector (14 pins) to connect the control power supply, the regeneration resistor, and the electromagnetic brake.

■ **Pin assignment**

There are two terminals for 0 V: one for control power supply and the other for internal connection. Refer to the figure and the table to check each position.

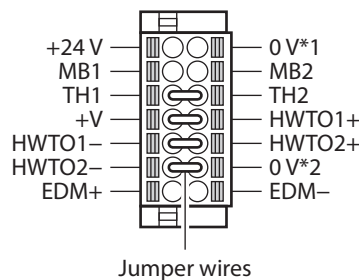

Sign	Description
+24 V, 0 V*1	Connects a control power supply.
MB1, MB2	Connects the lead wires from the cable for electromagnetic brake. MB1: Electromagnetic brake- (Black) MB2: Electromagnetic brake+ (White)
TH1, TH2	Connects the signal lines of the Oriental Motor regeneration resistor <b>RGB200</b> . If the regeneration resistor is not used, connect a jumper wire between the terminals to short-circuit as shown in the figure.
HWTO1+, HWTO1- HWTO2+, HWTO2-	Connects the external device. When using the power removal function, remove the jumper wires and connect the external device. If the power removal function is not used, connect jumper wires between the terminals to short-circuit as shown in the figure.
EDM+, EDM-	Connects the external device. If the power removal function is not used, do not connect anything.
+V, 0 V*2	These are for internal connection. Do not connect anything. If the power removal function is not used, connect jumper wires between the terminals to short-circuit as shown in the figure.

### ■ Wiring method of CN1 connector

- Applicable lead wire: AWG 24 to 16 (0.2 to 1.25 mm<sup>2</sup>)
- Stripping length of wire insulation: 10 mm (0.39 in.)

1. Strip the insulation of the lead wire.
2. Insert the lead wire while pushing the button of the orange color with a screwdriver.
3. After having inserted, release the button to secure the lead wire.

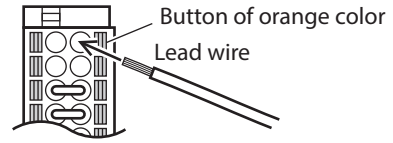

#### Note

When inserting a lead wire, make sure that the strand does not come into contact with the adjacent lead wire and the terminal. This may cause a short circuit between the strand and the lead wire or between the strand and the terminal, damaging the motor, the driver, or user's power supply equipment.

### ■ Connecting the control power supply

Use a control power supply with the following capacity.

The control power supply is a power supply for control circuit. Be sure to connect it.

Product model to be combined	Input power supply voltage	Power supply current capacity	
		Without electromagnetic brake	With electromagnetic brake
AZXM640 AZXM940	24VDC±5 %	0.27 A	0.57 A
AZXM960 AZXM1260 DGM200			0.62 A
AZXM1075 AZXM1175			—

### ■ Connecting the regeneration resistor

#### ● When using the built-in regeneration resistor

The driver has the built-in regenerative resistor. TH1 and TH2 terminals of CN1 as well as RG2 and RG3 terminals of CN4 are short-circuited at the time of shipment. This is the setting that the built-in regeneration resistor is used. Using the built-in regeneration resistor, however, continuous regeneration operation, vertical drive such as gravitational operation, or sudden start-stop operation of a large inertia cannot be performed. When performing such operation, use the Oriental Motor regeneration resistor **RGB200**.

#### ● When using the Oriental Motor regeneration resistor RGB200

- The two thin lead wires (AWG 20: 0.5 mm<sup>2</sup>) of the regeneration resistor are the thermostat outputs. Connect them to the TH1 and TH2 terminals using the CN1 connector.
- Regenerative current flows through the two thick lead wires (AWG 18: 0.75 mm<sup>2</sup>) of the regeneration resistor. Connect them to the RG1 and RG3 terminals using the CN4 connector.

Regeneration resistor **RGB200**

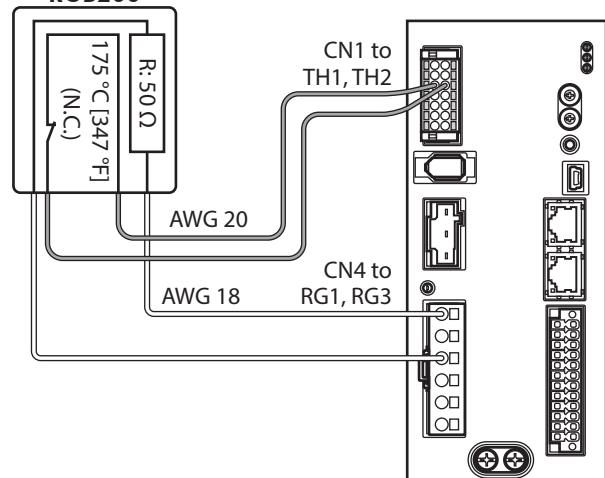



- When connecting the regeneration resistor, remove the jumper wires from the CN1 and CN4 connectors.
- If the power consumption of the regeneration resistor exceeds the allowable level, the thermostat will be triggered to generate an alarm of Regeneration resistor overheat. When an alarm of Regeneration resistor overheat is generated, turn off the main power supply and check the error content.

● **Regeneration resistor specifications**

Install the regeneration resistor in a location where heat dissipation capacity equivalent to a level achieved with a aluminum plate [350×350×3 mm (13.78×13.78×0.12 in.)] is ensured.

Model	<b>RGB200</b>
Permissible power consumption	Continuous regenerative power: 200 W Instantaneous regenerative power: 2,250 W
Resistance value	50 Ω
Thermostat operating temperature	Operation: Opens at 175±5 °C (347±9 °F) Reset: Closes at 115±15 °C (239±27 °F) (normally closed)
Thermostat electrical rating	227 VAC, 8 A 115 VAC, 22 A



The regeneration resistor main body will reach a high temperature. Be sure to use it with the protection cover to prevent hands from touching. Failure to do so may result in a skin burn(s).

**8-3 Connecting the main power supply (CN4)**

The driver can also be used with a power supply of single-phase 200-240 VAC. The connection method varies depending on the power supply specifications.

Three-phase 200-240 VAC –15 to +6 %  
50/60 Hz

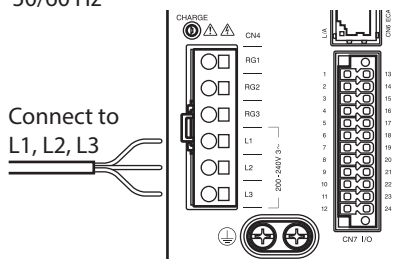

Single-phase 200-240 VAC –15 to +6 %  
50/60 Hz

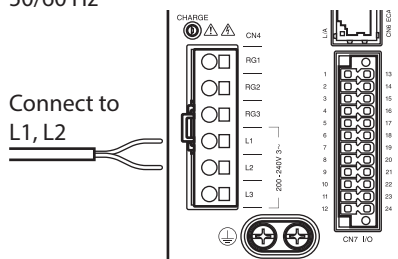

■ **Wiring method of CN4 connector**

- Applicable lead wire: AWG 18 to 14 (0.75 to 2.0 mm<sup>2</sup>)
- Stripping length of wire insulation: 8.5 mm (0.33 in.)

1. Strip the insulation of the lead wire.
2. Insert the connector lever.
3. Insert the lead wire while pushing down the connector lever.
4. After having inserted, release the connector lever to secure the lead wire.

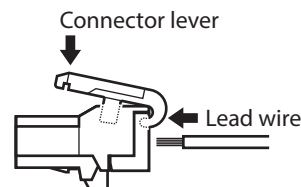

When inserting a lead wire, make sure that the strand does not come into contact with the adjacent lead wire and the terminal. This may cause a short circuit between the strand and the lead wire or between the strand and the terminal, damaging the motor, the driver, or user's power supply equipment.

## ■ Power supply current capacity

The current capacity for the main power supply varies depending on the product combined.

### ● Three-phase 200-240 VAC

Product model to be combined	Power supply current capacity
<b>AZXM640</b>	3.0 A or more
<b>AZXM940</b>	3.0 A or more
<b>AZXM960</b>	3.9 A or more
<b>AZXM1260</b>	3.9 A or more
<b>DGM200</b>	3.9 A or more
<b>AZXM1075</b>	4.8 A or more
<b>AZXM1175</b>	4.8 A or more

### ● Single-phase 200-240 VAC

Product model to be combined	Power supply current capacity
<b>AZXM640</b>	5.3 A or more
<b>AZXM940</b>	5.3 A or more
<b>AZXM960</b>	7.1 A or more
<b>AZXM1260</b>	7.1 A or more
<b>DGM200</b>	7.1 A or more
<b>AZXM1075</b>	8.7 A or more
<b>AZXM1175</b>	8.7 A or more

## 8-4 Grounding the driver

Two Protective Earth Terminals (screw size: M4) are provided on the driver. Be sure to ground one of the Protective Earth Terminals. Either of the two Protective Earth Terminals can be used for grounding the driver.

- Grounding wire: AWG 16 to 14 (1.25 to 2.0 mm<sup>2</sup>)
- Tightening torque: 1.2 N·m (170 oz-in)

Connect the grounding wire of the cable for motor to the other terminal to ground the motor.

Do not share the grounding wire with a welder or any other power equipment.

When grounding the Protective Earth Terminal, use a round terminal and secure the grounding point near the driver.

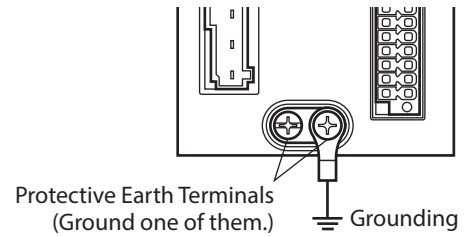

## 8-5 Connecting the EtherCAT cable (CN5, CN6)

Use the EtherCAT cable to connect an MainDevice to the CN5 connector (ECAT IN) of the driver. Be sure to connect from the CN6 (ECAT OUT) connector to the CN5 (ECAT IN) connector when connecting between drivers.

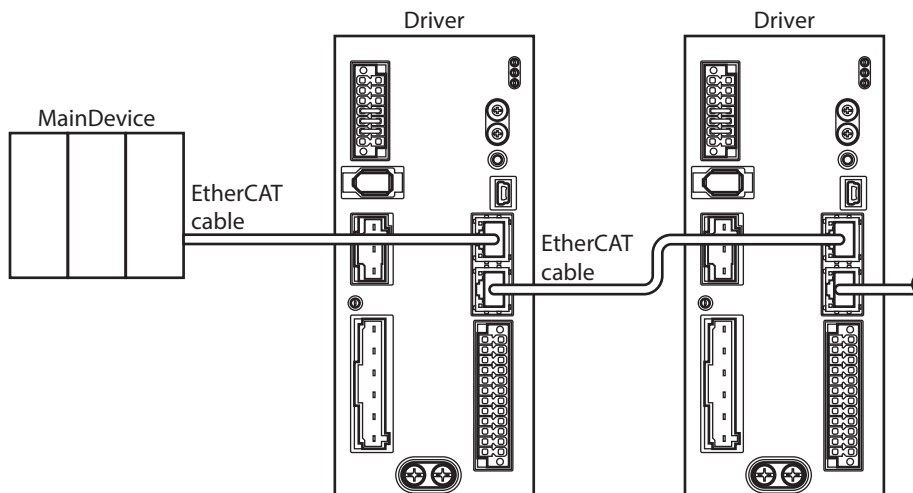

### Pin assignment

Signal name	Description
TXP	Transmitted data +
TXN	Transmitted data -
RXP	Received data +
N.C.	-
N.C.	-
RXN	Received data -
N.C.	-
N.C.	-

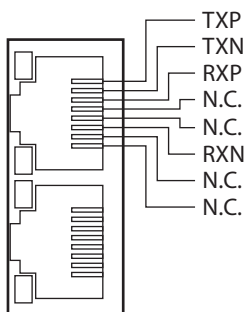

## 8-6 Connecting the USB cable

Use a USB cable with the following specifications to connect a PC on which the **MEXE02** software has been installed to the USB connector.

Specifications	USB2.0 (Full speed)
Cable	Length: 3 m (9.8 ft.) or less Shape: A to mini B



- Use a USB cable to connect the driver directly to a PC.
- In large electrically noisy environments, use the USB cable with a ferrite core or install a ferrite core on the USB cable.

## 8-7 Connecting the I/O signals (CN7)

Connect when using direct I/O or sensors.

### ■ Pin assignment

Pin No.	Signal name	Description*
1	NC	No connection
2	NC	No connection
3	IN0	Control input 0 (HOMES)
4	IN2	Control input 2 (ETO-CLR)
5	IN-COM 0-3	IN0 to IN3 inputs common
6	IN4	Control input 4 (FW-LS)
7	OUT0	Control output 0 (HOME-END)
8	OUT2	Control output 2 (Not used)
9	OUT4	Control output 4 (MOVE)
10	OUT-COM	Output common
11	ASG+	Phase A pulse output positive
12	BSG+	Phase B pulse output positive

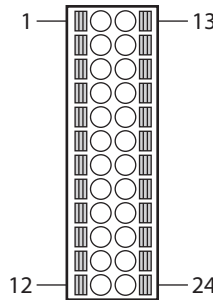

Pin No.	Signal name	Description*
13	NC	No connection
14	NC	No connection
15	IN1	Control input 1 (FREE)
16	IN3	Control input 3 (EXT1)
17	IN-COM 4-5	IN4, IN5 inputs common
18	IN5	Control input 5 (RV-LS)
19	OUT1	Control output 1 (ETO-MON)
20	OUT3	Control output 3 (SON-MON)
21	OUT5	Control output 5 (ALM-B)
22	GND	GND
23	ASG-	Phase A pulse output negative
24	BSG-	Phase B pulse output negative

\* ( ): Initial value

### ■ Wiring method of CN7 connector

- Applicable lead wire: AWG 24 to 16 (0.2 to 1.25 mm<sup>2</sup>)
- Stripping length of wire insulation: 10 mm (0.39 in.)

1. Strip the insulation of the lead wire.
2. Insert the lead wire while pushing the button of the orange color with a screwdriver.
3. After having inserted, release the button to secure the lead wire.

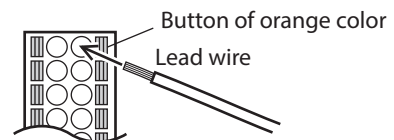

**Note** When inserting a lead wire, make sure that the strand does not come into contact with the adjacent lead wire and the terminal. This may cause a short circuit between the strand and the lead wire or between the strand and the terminal, damaging the motor, the driver, or user's power supply equipment.

**memo** Wire the I/O signal cable as short as possible. The maximum input frequency will decrease as the cable length increases.



### ■ Connection example with a current sink output circuit

Values in parentheses ( ) in the figure are initial values.

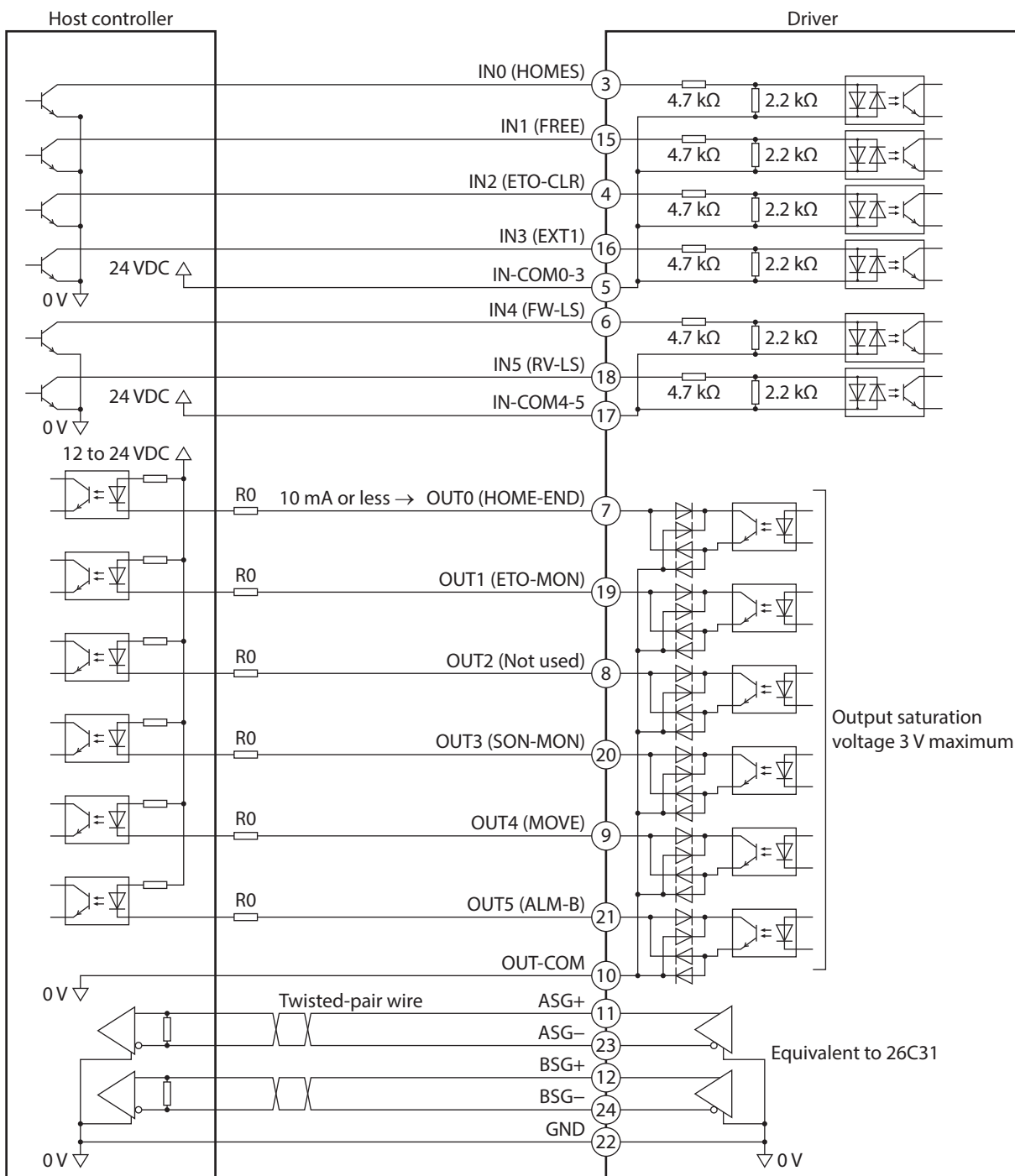

- Use input signals at 24 VDC.
- Use output signals at 12 to 24 VDC, 10 mA or less. If the current exceeds 10 mA, connect an external resistor R0 to keep the current at 10 mA or less.
- The saturation voltage of the output signal is 3 V maximum.

### ■ Connection example with a current source output circuit

Values in parentheses ( ) in the figure are initial values.

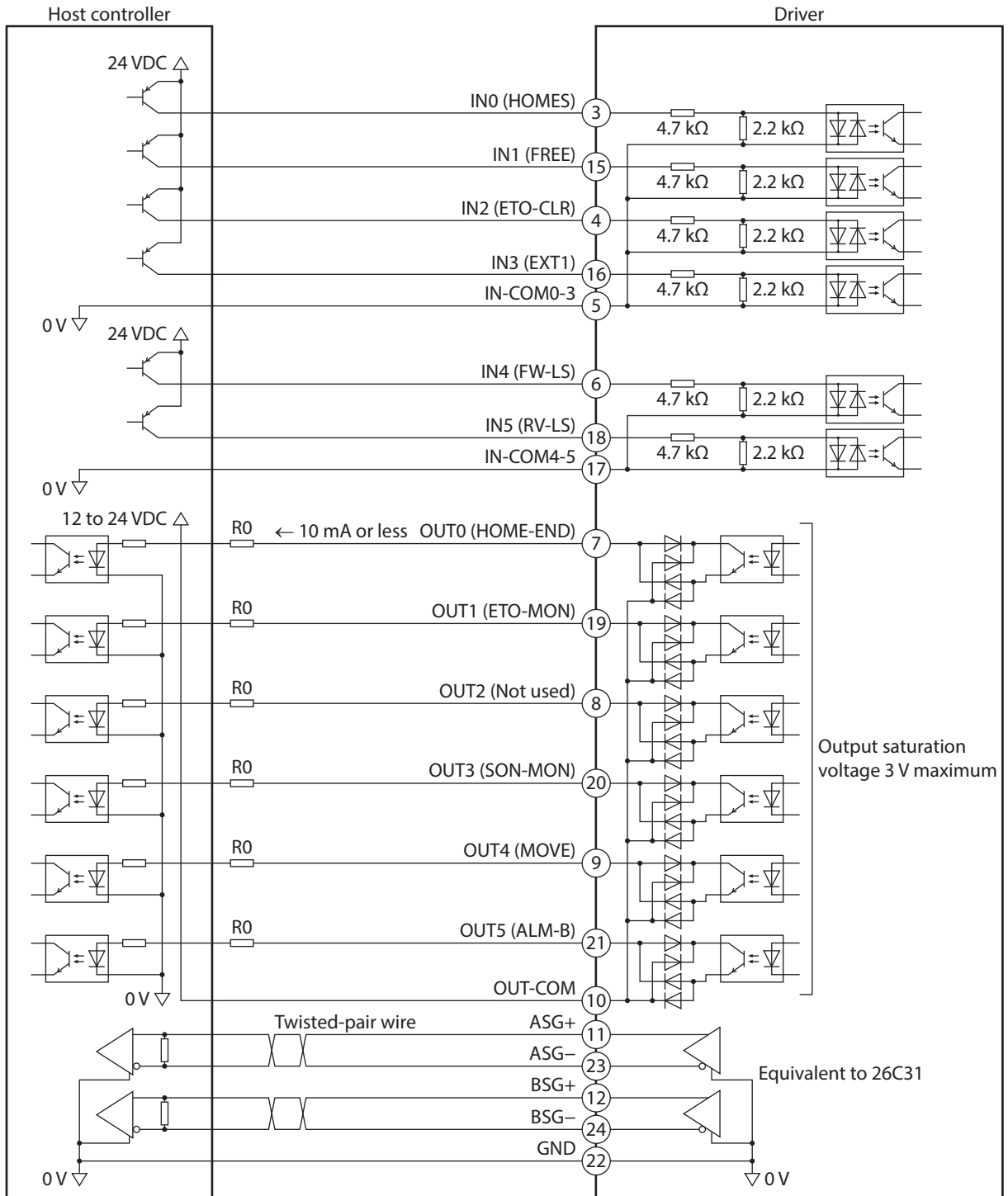

- Use input signals at 24 VDC.
- Use output signals at 12 to 24 VDC, 10 mA or less. If the current exceeds 10 mA, connect an external resistor R0 to keep the current at 10 mA or less.
- The saturation voltage of the output signal is 3 V maximum.

## 8-8 Noise elimination measures

There are two types of electrical noises: One is a noise to invade into the driver from the outside and cause the driver malfunction, and the other is a noise to emit from the driver and cause peripheral equipment malfunction. For the noise that is invaded from the outside, take measures to prevent the driver malfunction. It is necessary to take adequate measures because the signal lines are very likely to be affected by the noise. For the noise that is emitted from the driver, take measures to suppress it.

### ■ Measures against electrical noise

There are the following three methods mainly to take measures against the electrical noise.

#### ● Noise suppression

- When relays or electromagnetic switches are used, use noise filters or CR circuits to suppress surge generated by them.
- Use an Oriental Motor connection cable when extending the wiring distance between the motor and the driver. Refer to p.41 for the model name. This is effective in suppressing the electrical noise emitted from the motor.
- Cover the driver by a metal plate such as aluminum. This is effective in shielding the electrical noise emitted from the driver.

#### ● Prevention of noise propagation

- Connect a noise filter to the power supply cable of the driver.
- Keep power lines, such as motor and power supply cables, at least 200 mm (7.87 in.) away from signal lines, and do not bundle or parallel them. If a power cable and a signal cable must cross, cross them at right angles.
- Use shielded twisted pair cables for power lines and signal lines.
- Keep cables as short as possible without coiling and bundling extra lengths.
- Grounding multiple points will increase the effectiveness of blocking electrical noise because the impedance at the grounding points will be reduced. However, ground them to a stable potential so that there is no potential difference between the grounding points. I/O signal cables that include a grounding wire are provided in Oriental Motor products. Refer to p.45 for the model name.
- To ground a shielded cable, use a metal cable clamp that can maintain contact with the entire circumference of the shielded cable, and ground as close to the product as possible.

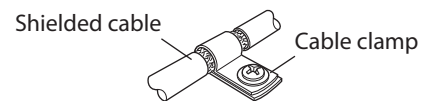

#### ● Suppression of effect by noise propagation

Loop the cable where the noise is propagated around a ferrite core. This will prevent the propagated noise from invading into the driver or emitting from the driver. The frequency band in which an effect by the ferrite core can be seen is generally 1 MHz or more. Check the frequency characteristics of the ferrite core used. To increase the noise attenuation effect of the ferrite core, loop the cable many times.

### ■ Noise suppression products

#### ● Noise filter

- Connect the following noise filter (or equivalent) to the power line. This will prevent the noise from propagating through the power line. Install the noise filter as close to the driver as possible.

Manufacturer	Three-phase 200-240 VAC	Single-phase 200-240 VAC
SOSHIN ELECTRIC CO., LTD.	HF3010C-SZA	HF2010A-UPF

- Use the AWG 16 (1.25 mm<sup>2</sup>) or thicker wire for the input and output cables of the noise filter, and secure firmly using a cable clamp or others so that the cable does not come off the enclosure.
- Keep the input cable as far away from the output cable as possible and do not wire the cables in parallel. If the input and output cables are placed at a close distance or wired in parallel, the noise in the enclosure will affect the power cable through stray capacitance, and the noise suppression effect will be reduced.
- For a wire to ground the noise filter, use a wire that is as thick as possible to ground the shortest distance possible.
- When connecting a noise filter in an enclosure, wire the input cable of the noise filter as short as possible. Wiring over a long distance may reduce the noise suppressing effect.

## ■ Oriental Motor's noise suppression products

### ● I/O signal cables

This is a shielded cable for good noise immunity to connect the driver and host controller. The grounding wires useful for grounding are come out of both ends of the cable. Refer to p.45 for the model name. The EMC testing is conducted using Oriental Motor I/O signal cable.

### ● Surge suppressors

These are effective in suppressing the surge that occurs in a relay contact part. Connect when using a relay or electromagnetic switch. A CR circuit for surge suppression and a CR circuit module are provided. Refer to p.46 for the model name.

## 8-9 Compliance with EMC Directive/Regulations

Effective measures must be taken against the EMI that the motor and driver may give to adjacent control system equipment, as well as the EMS of the motor and driver itself, to prevent the occurrence of serious malfunctions in the functions of the mechanical device. Using the following installation and wiring methods will enable the motor and driver to comply with the EMC Directive/Regulations.

Oriental Motor conducts EMC testing on its motors and drivers in accordance with "Example of installation and wiring" on p.29.

The user is responsible for ensuring the machine's compliance with EMC, based on the installation and wiring explained below.

### CAUTION

This equipment is not intended for use in residential environments nor for use on a low-voltage public network supplied in residential premises, and it may not provide adequate protection to radio reception interference in such environments.

### ● Connecting the noise filter

In large electrically noisy environments, connect a noise filter. Refer to "Noise filter" on p.27 for details.

### ● Connecting the control power supply

Use a power supply that complies with the EMC Directive/Regulations for the control power supply.

Use shielded cables and keep wiring and grounding as short as possible.

Refer to "Prevention of noise propagation" on p.27 for how to ground the shielded cable.

### ● Connecting the motor cable

Use an Oriental Motor connection cable when extending the wiring distance between the motor and the driver. Refer to p.41 for the model name.

### ● Connecting the signal cable

Refer to "Prevention of noise propagation" on p.27.

### ● Grounding method

- For a cable used to ground the motor, driver, and noise filter, use a cable that is as thick as possible to ground the shortest distance possible.
- Choose a large, thick and uniformly conductive surface for the grounding point.
- Ground the Protective Earth Terminals for the motor and the driver. Refer to p.22 for the grounding method.

● **Example of installation and wiring**

The figure shows an example when the cable type electromagnetic brake motor is used.

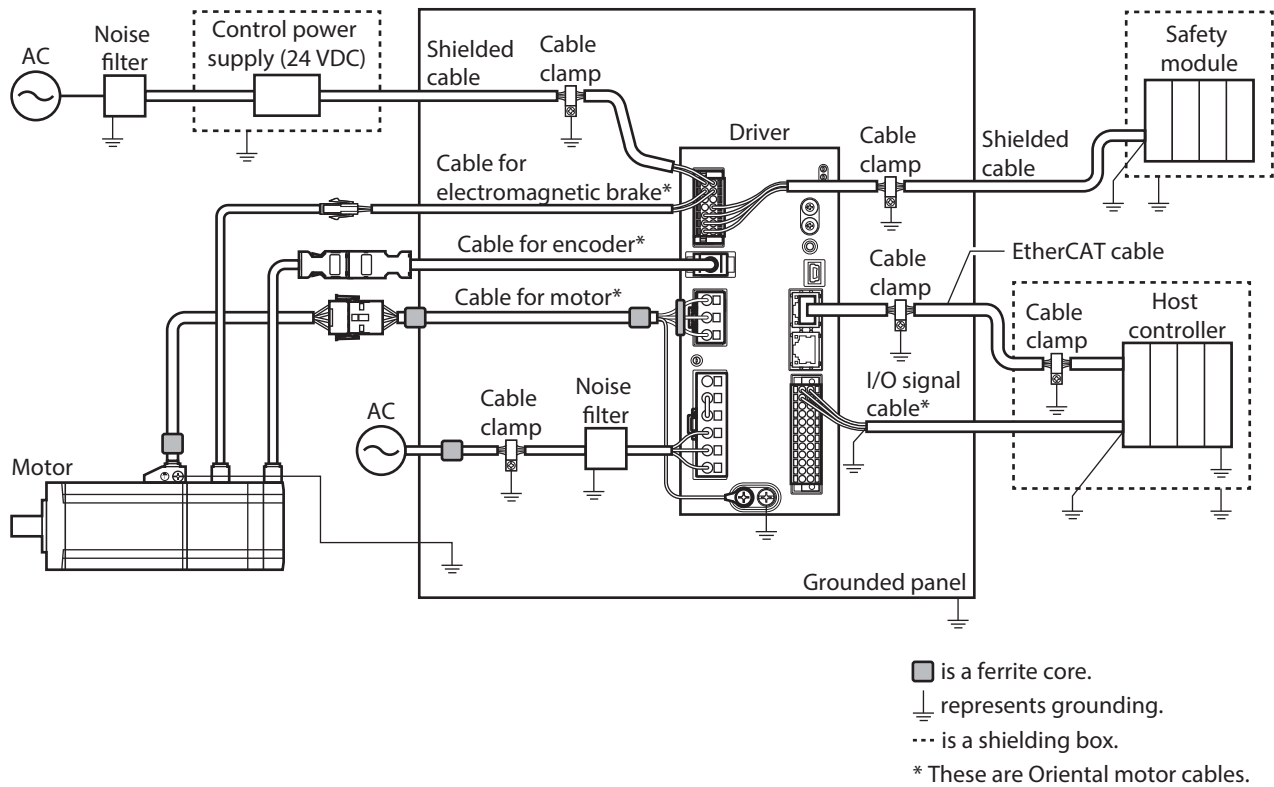

**Note** The driver uses components that are sensitive to static electricity. Take measures against static electricity since it may cause the driver to malfunction or be damaged.

- memo**
- When using the Oriental Motor **RGB200** regeneration resistor, install a ferrite core on the thick lead wire (AWG 18) of the regeneration resistor.
  - Connect a termination resistor even if only the wiring for the phase A and phase B pulse outputs is provided.

# 9 Power removal function

The power removal function is a function that stops supplying the power to the motor by the hardware. This function shuts off the drive signal of the inverter circuit that controls the motor current by two input channels (HWTO1 input, HWTO2 input). This will bring the power supply to the motor to a shut-off state (power removal status). The power removal function is assumed to be used to prevent unexpected starting of the moving parts of equipment when an operator works inside the operating range of the moving parts.

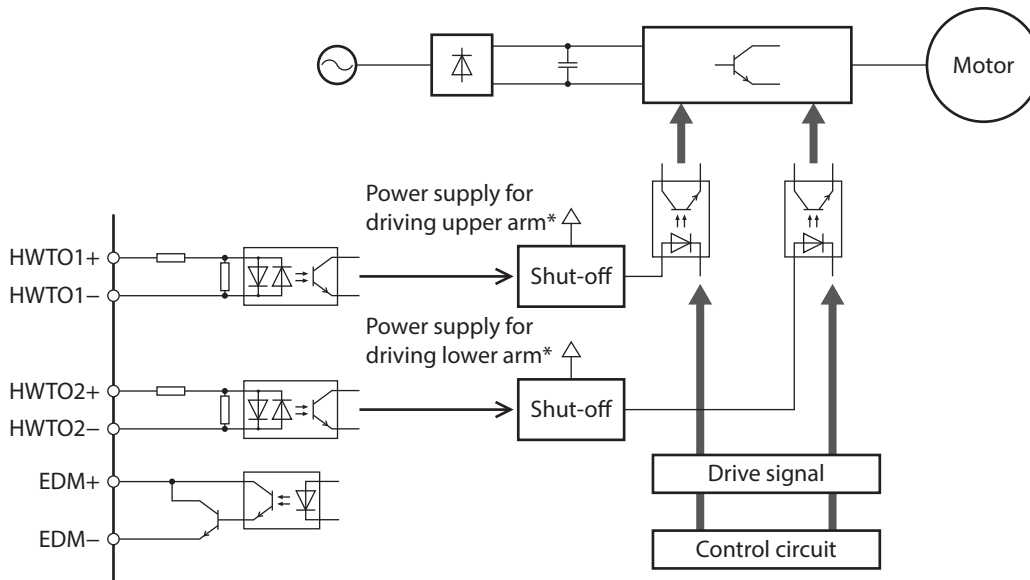

\* Turning the HWTO1 input OFF causes the upper arm drive signal of the inverter circuit to shut off. Turning the HWTO2 input OFF causes the lower arm drive signal of the inverter circuit to shut off.

**Note** Be sure to check the motor is in a standstill state before executing the power removal function. If the power removal function is executed while the motor is in operation, it may cause damage to the motor, driver, or equipment.

## 9-1 Safety parameters

Item	Specifications
Safety integrity level	SIL 3*
Average frequency of a dangerous failure per hour	PFH=2.32×10 <sup>-9</sup> [1/h]
Hardware fault tolerance	HFT=1
Subsystem	Type A
Mission time	20 years
Response time	15 ms or less
Performance level	PL e (Category 3)*
Mean time to dangerous failure	MTTFd: High
Average diagnostic coverage	DC <sub>avg</sub> : Medium
Stop category	0 (IEC 60204-1)

\* It is necessary to monitor the EDM output using an external device.

## 9-2 Notes when using the power removal function

- When the power removal function is used, be sure to conduct a risk assessment of equipment in advance and check that the safety requirements of the safety-related parts of a control system are satisfied.
- The design of the safety-related parts of a control system using the power removal function should be performed by qualified personnel who are trained in the relevant safety standards and understand the contents of this chapter.
- If the power removal function is activated, the output shaft may be rotated by external forces (gravity on a vertical axis, etc.). To hold the output shaft in position, install an external brake mechanism or equivalent. The brake mechanism of the electromagnetic brake motor is used for the purpose to hold the position. Do not use the brake mechanism of the electromagnetic brake motor for braking the motor rotation. This may result in injury or damage to equipment.
- If the power removal function is activated, the driver stops supplying the power to the motor. However, the power supplying to the driver is not shut off, and the driver is not electrically insulated either. Before performing any maintenance or inspection, always turn off the driver power and check that the CHARGE LED is turned off. Failure to do so may result in electric shock.
- If the inverter circuit is failed, the motor output shaft may rotate up to 180 degrees in an electrical angle (30 degrees in a mechanical angle) even when the power removal function is activated. Make sure that this movement does not cause hazardous situations. Failure to do so may result in injury or damage to equipment.
- Connect the I/O signals related to the power removal function to an external device that conforms to the safety standard.
- Be sure to perform the verification testing of the power removal function when starting up or maintaining the equipment, or when replacing the driver. Failure to do so may result in injury or damage to equipment. If the power removal function is used in an incorrect state, such as when I/O signals are wired incorrectly, the power removal function may not be activated properly, resulting in a hazardous situation.

## 9-3 I/O signals

### ■ HWTO1 input, HWTO2 input

These signals are used to activate the power removal function.  
Connect 24 VDC to HWTO1+ and HWTO2+ and 0 V to HWTO1- and HWTO2-.

**Note** Provide individual contacts for operating the HWTO1 input and the HWTO2 input.

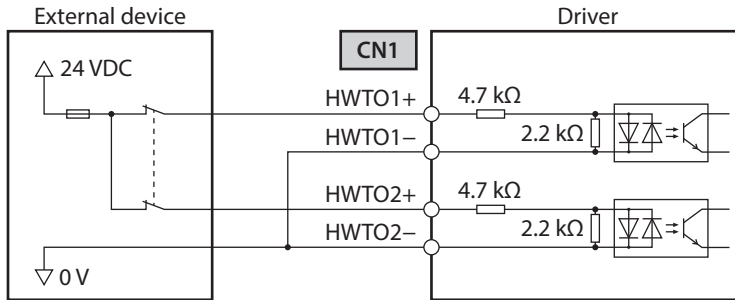

#### Specification

- Input voltage: 24 VDC±10 %

#### Safety input-off shot pulse for self-diagnosis of external device

If the safety output signal output from an external device includes the safety input-off shot pulse for self-diagnosis, use an external device with a pulse width of 1 ms or less. If the OFF-time of the HWTO1 input or the HWTO2 input by the safety input-off shot pulse is 1 ms or less, the power removal function is not activated.

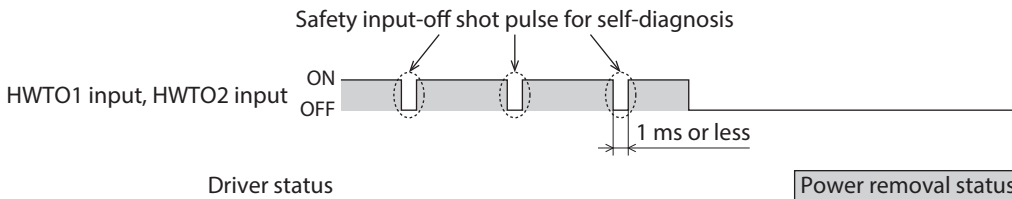

### ■ EDM output

The EDM output is a signal to monitor a failure in the power removal function.

**Note** The EDM output is not an output signal to ensure the safety. Do not use the EDM output for any purpose other than monitoring for failures.

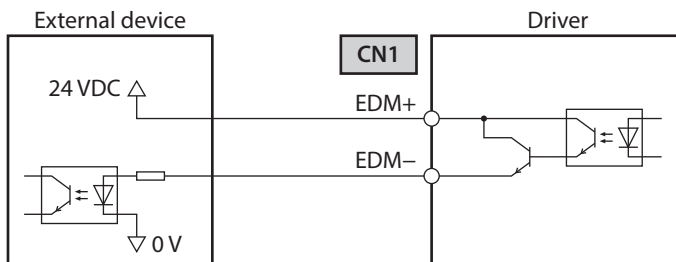

#### Specifications

- Voltage: 30 VDC or less
- Current: 50 mA or less
- Output saturation voltage: 1.1 V maximum



## 9-4 Operation of power removal function

### ■ Transition to power removal status

If both the HWTO1 and HWTO2 inputs are turned OFF, the driver will transition to the power removal status, and the power supplying to the motor will be cut off by the hardware, placing the motor in a non-excitation state. In the power removal status, the status of the motor and driver will be as follows. [When the HWTO mode selection (4190h) is set to "0: Alarm is not present (initial value)"]

- The ETO-MON output is ON.
- The DCMD-RDY output, the READY output, and the MBC output are OFF.
- The PWR/ALM LED blinks in green.
- When an electromagnetic brake motor is used, the electromagnetic brake is in a state of holding the motor shaft.

#### Note

- Be sure to check the motor is in a standstill state before executing the power removal function. If the power removal function is executed while the motor is in operation, it may cause damage to the motor, driver, or equipment.
- It takes 15 ms maximum from when the HWTO1 and HWTO2 inputs are turned OFF until when the driver is in the power removal status.
- To transition to the power removal status, be sure to turn the HWTO1 and HWTO2 inputs OFF for at least 15 ms.
- The ETO-MON output, the DCMD-RDY output, the READY output, the MBC output, and the PWR/ALM LED, and the electromagnetic brake are not safety-related parts of a control system.

### ● Timing chart

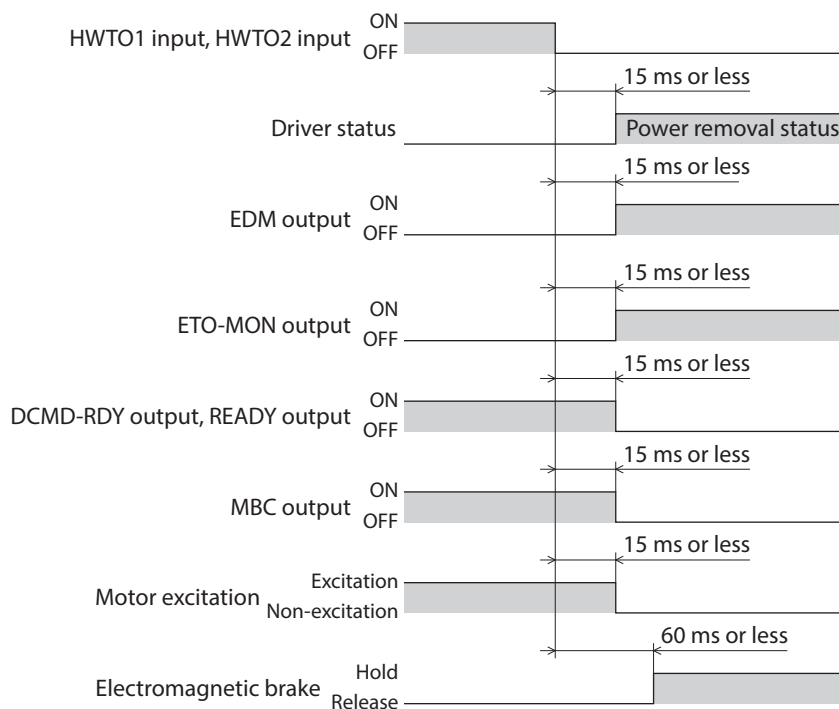

## Return from power removal status

If both the HWTO1 input and the HWTO2 input are turned ON, the power removal status is released. At this time, the motor remains in a non-excitation state.

To excite the motor, turn the ETO-CLR input ON in a state where the excitation command is input from the MainDevice. When the ETO-CLR input is turned ON, the status of the motor and driver will be as follows.

- The ETO-MON output is OFF.
- The DCMD-RDY output, the READY output, and the MBC output are ON.
- The PWR/ALM LED is lit in green.
- When an electromagnetic brake motor is used, the electromagnetic brake is in a state of releasing the motor shaft.



- Check that the equipment is in a safe state before returning the driver from the power removal status.
- Even if either the HWTO1 input or the HWTO2 input is turned ON, the power removal status cannot be released.
- If the ON-time of the HWTO1 and HWTO2 inputs is less than 15 ms, the power removal status may not be released.
- When the power removal status is released, a shut-off state of supplying the power to the motor by the hardware is also released.
- The ETO-CLR input is not a safety-related part of a control system.

### Timing chart

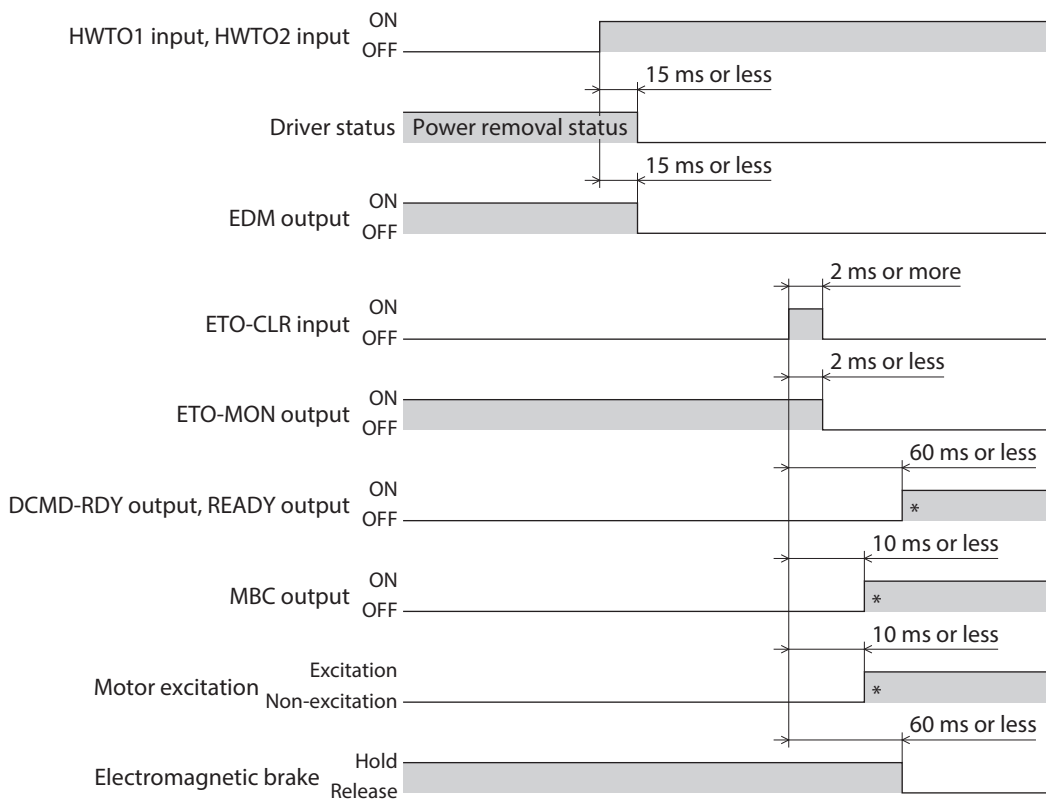

\* It is the movement when the excitation command is input from the MainDevice at the time the ETO-CLR input is turned ON.

## ■ Detection for failure of the power removal function

Monitoring the input status of the HWTO1 and HWTO2 inputs and the output status of the EDM output relative to the inputs can detect the failure of the power removal function.

When the power removal function is properly operated, the combination of each signal is any of the following. Combinations other than the table indicate the power removal function of the driver is in a failure state.

HWTO1 input	HWTO2 input	EDM output
ON	ON	OFF
OFF	OFF	ON
ON	OFF	OFF
OFF	ON	OFF

If only one of the HWTO1 input and the HWTO2 input is ON or OFF, the external device or wiring has failed. Check the cause and take a measure immediately. At this time, the EDM output will be in an OFF state and the motor will be in a non-excitation state.



- Do not release the power removal function when the EDM output is in an OFF state.
- If the driver or external device is failed or an error in wirings occurs, check the cause and take a measure immediately.
- The power removal function of the driver is classified in Category 3 of ISO 13849-1. Not all dangerous failures can be detected by the EDM output.

## 9-5 Example of use

This section describes the connection method that the power removal function is activated when the door (guard) is opened using a safety module.

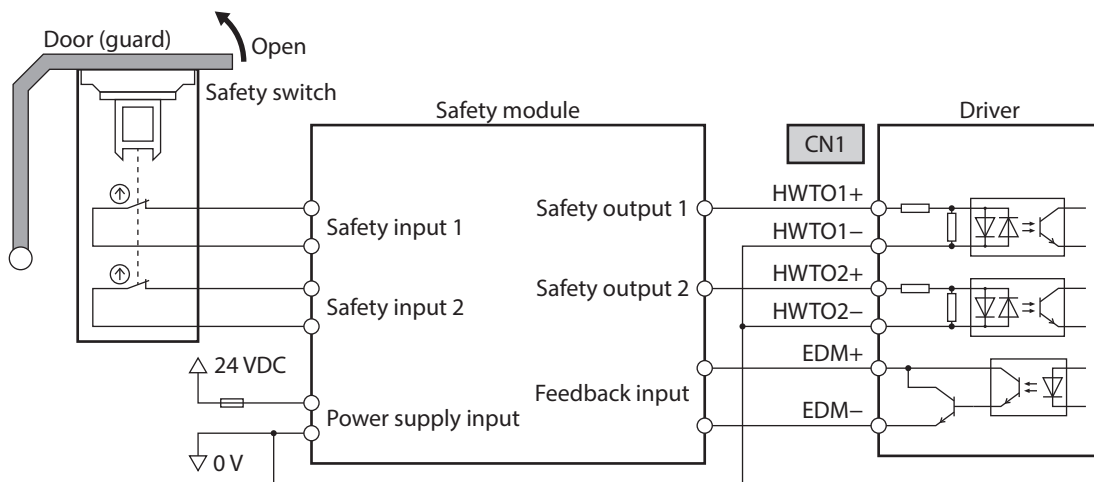

### ■ Operation in normal state

#### ● When the door (guard) is opened

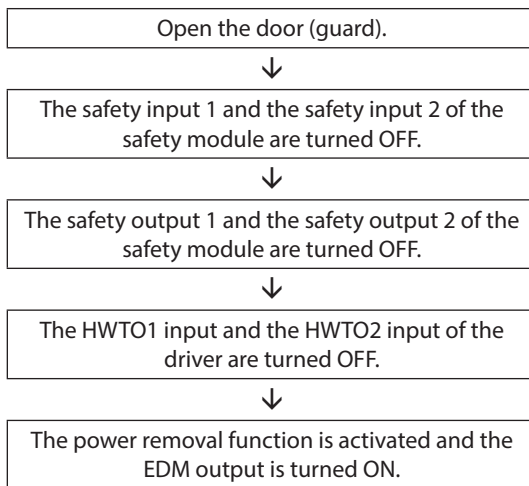

#### ● When the door (guard) is closed

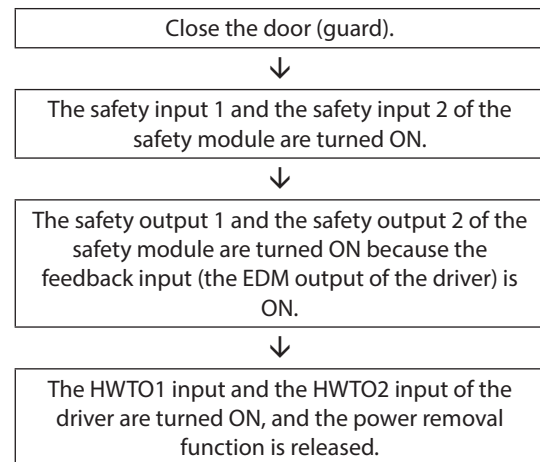

### ■ How to detect a failure

If a failure that the HWTO1 input or the HWTO2 input is not turned OFF occurs, the EDM output is not turned ON. A failure can be detected because the safety module is not reset even if the door (guard) is closed and the motor cannot be started.

## 9-6 Verification testing of power removal function

- Be sure to perform the verification testing of the power removal function when starting up or maintaining the equipment, or when replacing the driver.
- According to use conditions of the safety related parts of a control system, perform a verification test of the power removal function at least once three months.
- Keep the verification result on record.

### ■ Description of verification testing

1. Turn on the control power supply and main power supply of the driver while both the HWTO1 and HWTO2 inputs are an ON state.
2. Use the MainDevice to input the excitation command.
3. Check that the motor is in an excitation state and the EDM output is in an OFF state.
4. Turn both the HWTO1 and HWTO2 inputs OFF.
5. Check that the motor goes into a non-excitation state and the EDM output is turned ON.

## 9-7 Related functions

**Note** The related functions are not safety-related parts of a control system.

### ■ Input signal

#### ● ETO-CLR input

After both the HWTO1 input and the HWTO2 input are turned ON to release the power removal function, if the ETO-CLR input is turned ON in a state where the excitation command is input from the EtherCAT MainDevice, the motor goes into an excitation state.

#### Related parameter

MEXE02 code	Name	Description	Setting range	Initial value
p4	ETO reset action (ETO-CLR)	Sets the judgment criterion of the signal when the motor is excited by the ETO-CLR input.	1: ON edge 2: ON level	1

### ■ Output signals

#### ● HWTOIN-MON output

If the HWTO1 input or the HWTO2 input is turned OFF, the HWTOIN-MON output is turned ON.

#### ● ETO-MON output

If the HWTO1 input or the HWTO2 input is turned OFF when the "HWTO mode selection" parameter is set to "0: Alarm is not present," the ETO-MON output is turned ON. If the ETO-CLR input is turned ON after both the HWTO1 input and the HWTO2 input are turned ON, the ETO-MON output is turned OFF.

#### Related parameter

MEXE02 code	Name	Description	Setting range	Initial value
p4	HWTO mode selection	Generates an alarm when the HWTO1 input or the HWTO2 input is turned OFF.	0: Alarm is not present 1: Alarm is present	0

#### ● EDM-MON output

If both the HWTO1 input and the HWTO2 input are turned OFF, the EDM-MON output is turned ON.

**Note** Be sure to use the EDM output of CN1 to detect the failure of the power removal function.

### ■ Parameters

#### ● ETO reset ineffective period

The motor cannot be excited even if the ETO-CLR input is turned ON until the time set in the "ETO reset ineffective period" parameter has elapsed.

#### Related parameter

MEXE02 code	Name	Description	Setting range	Initial value
p4	ETO reset ineffective period	Sets a time to disable the ETO-CLR input when the motor is excited by the ETO-CLR input after both the HWTO1 and HWTO2 inputs are turned ON. The motor cannot be excited until the time set in this parameter is exceeded even if the ETO-CLR input is turned ON.	0 to 100 ms	0

**When the ETO-CLR input is turned ON before the time set in the “ETO reset ineffective period” parameter has elapsed (When the motor is excited at the ON edge)**

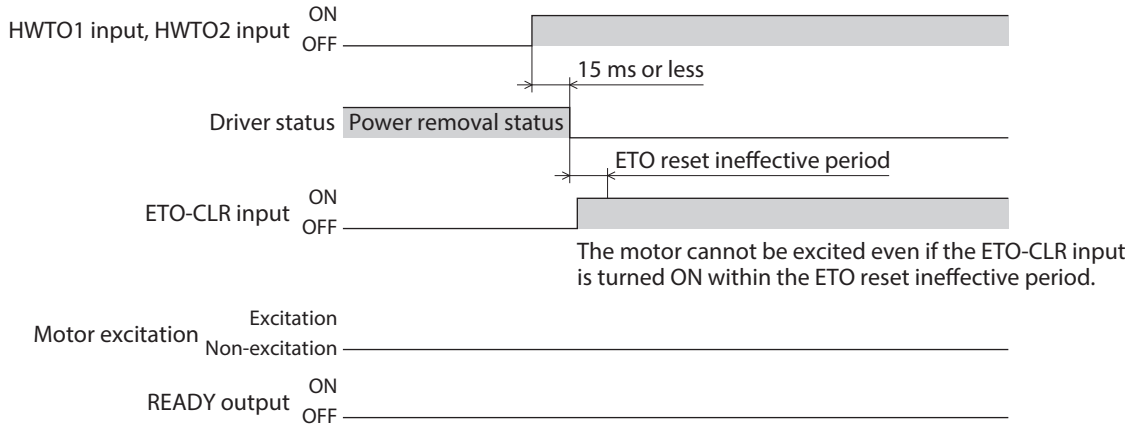

**When the ETO-CLR input is turned ON after the time set in the “ETO reset ineffective period” parameter has elapsed (When the motor is excited at the ON edge)**

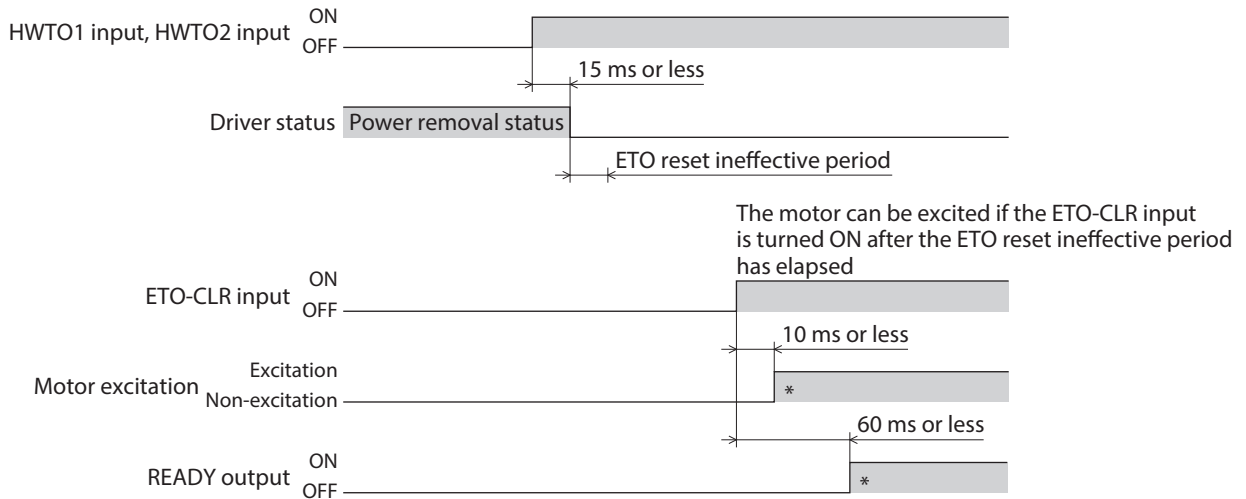

\* It is the movement when the excitation command is input from the EhterCAT MainDevice at the time the ALM-RST input is turned ON.

● **Signal criterion of ETO-CLR input**

If the “ETO reset action (ETO-CLR)” parameter is set to “2: ON-level,” the motor can be excited at the ON level of the ETO-CLR input instead of the ON edge. (Initial value: ON edge)

**Related parameter**

MEXE02 code	Name	Description	Setting range	Initial value
p4	ETO reset action (ETO-CLR)	Sets the judgment criterion of the signal when the motor is excited by the ETO-CLR input.	1: ON edge 2: ON level	1

- **Motor excitation by input signals other than ETO-CLR input**

The function to excite the motor can be set to the ALM-RST input and the STOP input using parameters. In the initial value, this function is set to the STOP input.

#### Related parameters

MEXE02 code	Name	Description	Setting range	Initial value
p4	ETO reset action (ALM-RST)	Excites the motor by the ALM-RST input after the HWTO1 input and the HWTO2 input are turned ON.	0: Disable 1: Excitation at ON edge	0
	ETO reset action (STOP)	Excites the motor by the STOP input after the HWTO1 input and the HWTO2 input are turned ON.		1

## ■ Alarms

- **Alarm of HWTO input detection**

If the "HWTO mode selection" parameter is set to "1: Alarm is present," an alarm will be generated when either the HWTO1 input or the HWTO2 input is turned OFF. (HWTO input detection, alarm code 68h)  
At this time, the PWR/ALM LED will blink red once and repeat.

When the "HWTO mode selection" parameter is set to "1: Alarm is present," the motor can be excited if the ALM-RST input is turned from OFF to ON after the power removal function is released. (It is enabled at the ON edge.)

#### Related parameter

MEXE02 code	Name	Description	Setting range	Initial value
p4	HWTO mode selection	Generates an alarm when the HWTO1 input or the HWTO2 input is turned OFF.	0: Alarm is not present 1: Alarm is present	0

- **Alarm of HWTO input circuit error**

If a time after either the HWTO1 input or the HWTO2 input is turned OFF until the other input is turned OFF exceeds the value set in the "HWTO delay time of checking dual system" parameter, an alarm will be generated. (HWTO input circuit error, alarm code 53h)

At this time, the PWR/ALM LED will blink red twice and repeat.

#### Related parameter

MEXE02 code	Name	Description	Setting range	Initial value
p4	HWTO delay time of checking dual system	Sets a threshold after either the HWTO1 input or the HWTO2 input is turned OFF until the other input is turned OFF. If the other input is not turned OFF even when the threshold is exceeded, an alarm will be generated.	0 to 10: Disable 11 to 100 ms	0

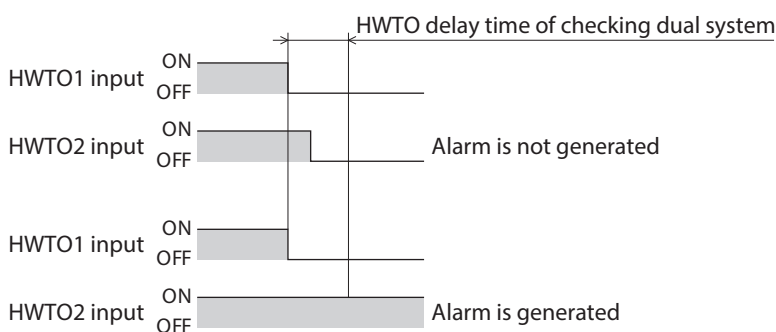

# 10 Inspection and maintenance

---

## 10-1 Inspection

It is recommended that periodic inspections are conducted for the items listed below after each operation of the motor. If any abnormality occurs, discontinue use of the product and contact your nearest Oriental Motor sales office.

### ■ Inspection items

- Check if the openings in the driver are clogged.
- Check if any of the mounting screws secured the driver is loose.
- Check if any of the connection parts of the driver is loose.
- Check if dust is deposited on the driver.
- Check if the driver has unusual smells or appearance defects.



The driver uses semiconductor components. Static electricity may damage the semiconductor components of the driver, so be extremely careful when handling them.

---

## 10-2 Warranty

Check on the Oriental Motor Website for the product warranty.

## 10-3 Disposal

Dispose the product correctly in accordance with laws and regulations, or instructions of local governments.



# 11 Cables

## 11-1 Connection cables (For cable type)

### ■ Connection cable sets / Flexible connection cable sets

These cables are used when connecting a motor and a driver. The cable set includes two cables for the motor and the encoder.

The cable set of electromagnetic brake motors includes three cables for the motor, the encoder, and the electromagnetic brake.

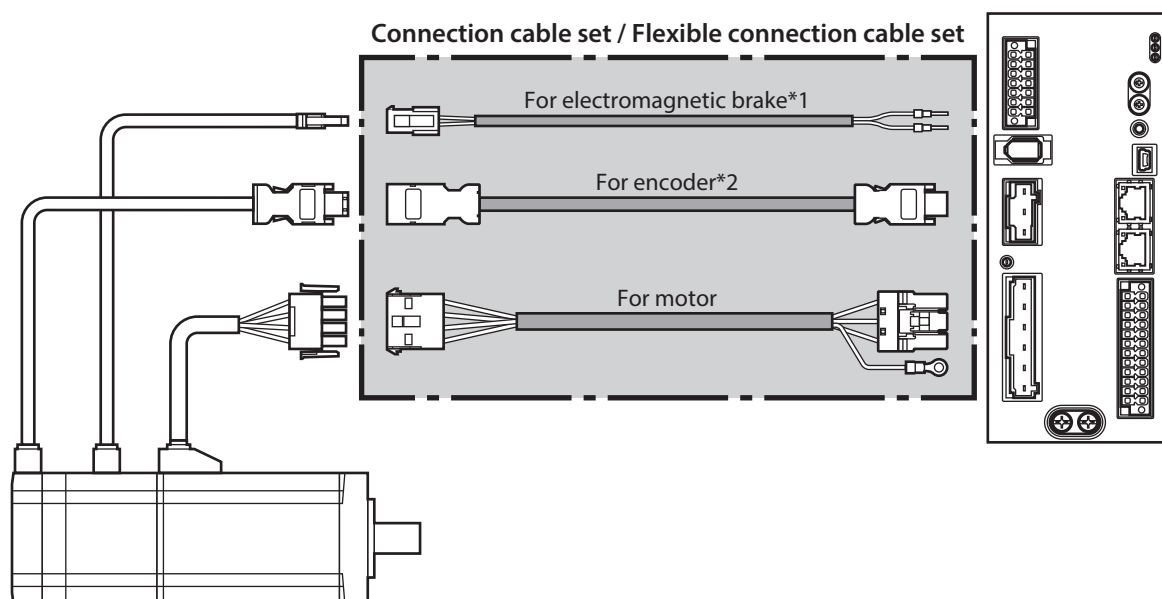

\*1 Only when the motor is the electromagnetic brake type.

\*2 Use the cable for encoder when the length of the encoder cable of motor is not enough.



When installing the motor on a moving part, use a flexible cable.

● **Connection cable sets**

**For motor/encoder**

Model	Length [m (ft.)]
<b>CC010VXF</b>	1 (3.3)
<b>CC020VXF</b>	2 (6.6)
<b>CC030VXF</b>	3 (9.8)
<b>CC050VXF</b>	5 (16.4)
<b>CC070VXF</b>	7 (23.0)
<b>CC100VXF</b>	10 (32.8)
<b>CC150VXF</b>	15 (49.2)
<b>CC200VXF</b>	20 (65.6)

**For motor/encoder/electromagnetic brake**

Model	Length [m (ft.)]
<b>CC010VXFB</b>	1 (3.3)
<b>CC020VXFB</b>	2 (6.6)
<b>CC030VXFB</b>	3 (9.8)
<b>CC050VXFB</b>	5 (16.4)
<b>CC070VXFB</b>	7 (23.0)
<b>CC100VXFB</b>	10 (32.8)
<b>CC150VXFB</b>	15 (49.2)
<b>CC200VXFB</b>	20 (65.6)

● **Flexible connection cable sets**

**For motor/encoder**

Model	Length [m (ft.)]
<b>CC010VXR</b>	1 (3.3)
<b>CC020VXR</b>	2 (6.6)
<b>CC030VXR</b>	3 (9.8)
<b>CC050VXR</b>	5 (16.4)
<b>CC070VXR</b>	7 (23.0)
<b>CC100VXR</b>	10 (32.8)
<b>CC150VXR</b>	15 (49.2)
<b>CC200VXR</b>	20 (65.6)

**For motor/encoder/electromagnetic brake**

Model	Length [m (ft.)]
<b>CC010VXRB</b>	1 (3.3)
<b>CC020VXRB</b>	2 (6.6)
<b>CC030VXRB</b>	3 (9.8)
<b>CC050VXRB</b>	5 (16.4)
<b>CC070VXRB</b>	7 (23.0)
<b>CC100VXRB</b>	10 (32.8)
<b>CC150VXRB</b>	15 (49.2)
<b>CC200VXRB</b>	20 (65.6)

● **Driver side connector of cable for motor**

The connector on the driver side of the cable for motor can be removed. When passing the cable for motor through a thin pipe, once remove the connector on the driver side if the connector cannot be inserted. Be sure to assemble the connector again after wiring the cable.

**How to remove the connector**

1. Insert the connector lever (included with the driver).
2. Remove the lead wire while pushing down the connector lever.

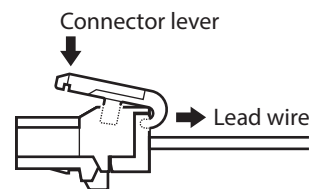

**How to wire the connector**

1. Insert the connector lever.
2. Insert the lead wire while pushing down the connector lever.
3. After having inserted, release the connector lever to secure the lead wire.

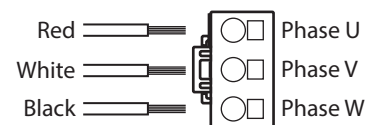

**Note** When inserting a lead wire, make sure that the strand does not come into contact with the adjacent lead wire and the terminal. This may cause a short circuit between the strand and the lead wire or between the strand and the terminal, damaging the motor, the driver, or user's power supply equipment.

## ■ Extension cable sets / Flexible extension cable sets

These cables are used when extending the connection cable (add between the motor and connection cable). Use if the length of the connection cable used is not enough when extending the distance between a motor and a driver.

The cable set includes two cables for the motor and the encoder. The cable set of electromagnetic brake motors includes three cables for the motor, the encoder, and the electromagnetic brake.

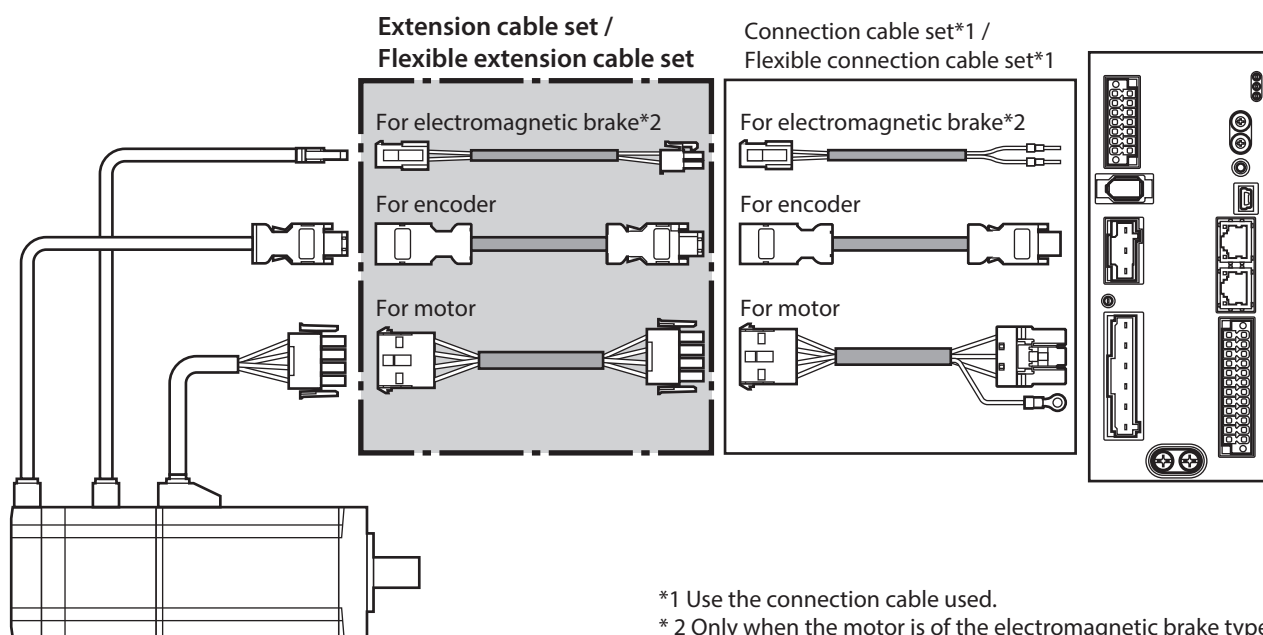

- When installing the motor on a moving part, use a flexible cable.
- When extending the wiring distance by connecting an extension cable to the connection cable, keep the total cable length to 20 m (65.6 ft.) or less.

### ● Extension cable sets

#### For motor/encoder

Model	Length [m (ft.)]
CC010VXFT	1 (3.3)
CC020VXFT	2 (6.6)
CC030VXFT	3 (9.8)
CC050VXFT	5 (16.4)
CC070VXFT	7 (23.0)
CC100VXFT	10 (32.8)
CC150VXFT	15 (49.2)

#### For motor/encoder/electromagnetic brake

Model	Length [m (ft.)]
CC010VXFBT	1 (3.3)
CC020VXFBT	2 (6.6)
CC030VXFBT	3 (9.8)
CC050VXFBT	5 (16.4)
CC070VXFBT	7 (23.0)
CC100VXFBT	10 (32.8)
CC150VXFBT	15 (49.2)

### ● Flexible extension cable sets

#### For motor/encoder

Model	Length [m (ft.)]
CC010VXRT	1 (3.3)
CC020VXRT	2 (6.6)
CC030VXRT	3 (9.8)
CC050VXRT	5 (16.4)
CC070VXRT	7 (23.0)
CC100VXRT	10 (32.8)
CC150VXRT	15 (49.2)

#### For motor/encoder/electromagnetic brake

Model	Length [m (ft.)]
CC010VXRBT	1 (3.3)
CC020VXRBT	2 (6.6)
CC030VXRBT	3 (9.8)
CC050VXRBT	5 (16.4)
CC070VXRBT	7 (23.0)
CC100VXRBT	10 (32.8)
CC150VXRBT	15 (49.2)

## 11-2 Connection cables (For connector type)

### ■ Connection cables / Flexible connection cables

These cables are used when connecting a motor and a driver.

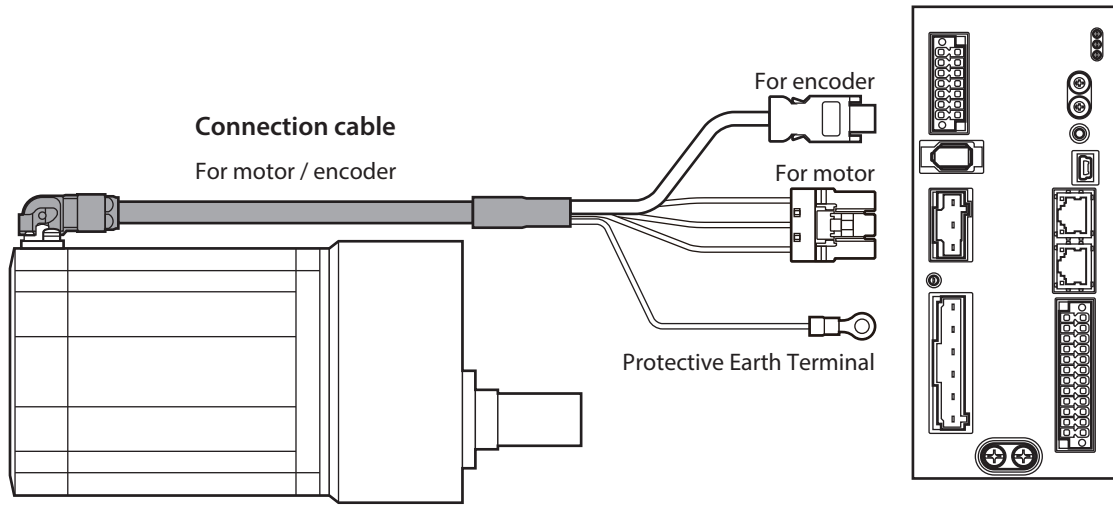

The model name of the connection cable varies depending on the outlet direction from the motor. Refer to the figures.

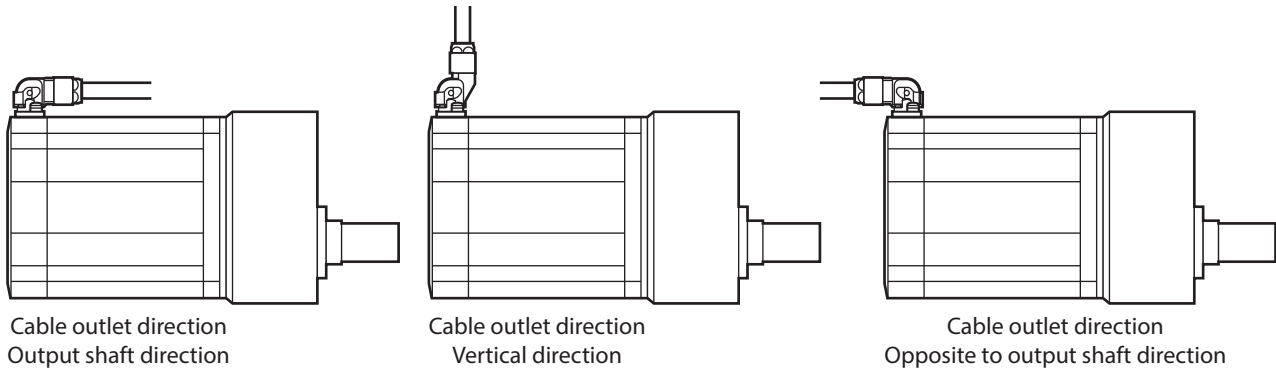

When installing the motor on a moving part, use a flexible cable.

### ● Connection cables

Length [m (ft.)]	Cable outlet direction		
	Output shaft direction	Vertical direction	Opposite to output shaft direction
0.5 (1.6)	<b>CCM005VXFF</b>	<b>CCM005VXVF</b>	<b>CCM005VXBF</b>
1 (3.3)	<b>CCM010VXFF</b>	<b>CCM010VXVF</b>	<b>CCM010VXBF</b>
2 (6.6)	<b>CCM020VXFF</b>	<b>CCM020VXVF</b>	<b>CCM020VXBF</b>
3 (9.8)	<b>CCM030VXFF</b>	<b>CCM030VXVF</b>	<b>CCM030VXBF</b>
5 (16.4)	<b>CCM050VXFF</b>	<b>CCM050VXVF</b>	<b>CCM050VXBF</b>
10 (32.8)	<b>CCM100VXFF</b>	<b>CCM100VXVF</b>	<b>CCM100VXBF</b>

### ● Flexible connection cables

Length [m (ft.)]	Cable outlet direction		
	Output shaft direction	Vertical direction	Opposite to output shaft direction
0.5 (1.6)	<b>CCM005VXFR</b>	<b>CCM005VXVR</b>	<b>CCM005VXBR</b>
1 (3.3)	<b>CCM010VXFR</b>	<b>CCM010VXVR</b>	<b>CCM010VXBR</b>
2 (6.6)	<b>CCM020VXFR</b>	<b>CCM020VXVR</b>	<b>CCM020VXBR</b>
3 (9.8)	<b>CCM030VXFR</b>	<b>CCM030VXVR</b>	<b>CCM030VXBR</b>
5 (16.4)	<b>CCM050VXFR</b>	<b>CCM050VXVR</b>	<b>CCM050VXBR</b>
10 (32.8)	<b>CCM100VXFR</b>	<b>CCM100VXVR</b>	<b>CCM100VXBR</b>

### ● About a connector for motor

The connector on the driver side of the cable for motor can be removed. When passing the cable for motor through a thin pipe, once remove the connector on the driver side if the connector cannot be inserted. Be sure to assemble the connector again after wiring the cable.

#### How to remove the connector

1. Insert the connector lever (included with the driver).
2. Remove the lead wire while pushing down the connector lever.

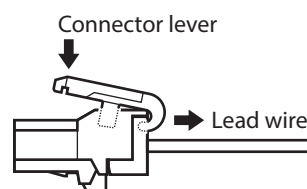

#### How to wire the connector

1. Insert the connector lever.
2. Insert the lead wire while pushing down the connector lever.
3. After having inserted, release the connector lever to secure the lead wire.

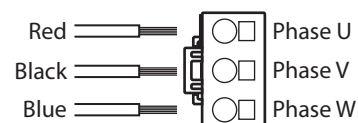

#### Note

- When inserting a lead wire, make sure that the strand does not come into contact with the adjacent lead wire and the terminal. This may cause a short circuit between the strand and the lead wire or between the strand and the terminal, damaging the motor, the driver, or user's power supply equipment.
- When using a cable with a ferrite core installed, do not remove the ferrite core. Doing so may cause the driver to malfunction or be damaged due to noise.

## 11-3 I/O signal cables

These are shielded cables offering good noise immunity to connect the I/O signals of the host controller to the driver. The grounding wires useful for grounding are come out of both ends of the cable. A connector is assembled at the driver side.

Model	Cable length [m (ft.)]	Number of lead wire cores
<b>CC24D005C-1</b>	0.5 (1.6)	24
<b>CC24D010C-1</b>	1 (3.3)	
<b>CC24D020C-1</b>	2 (6.6)	

# 12 Accessories

---

## 12-1 Relay contact protection parts/circuits

- **CR circuit for surge suppression**

This product is effective to suppress the surge which occurs in a relay contact part. Use it to protect the contacts of the relay or switch.

Model: **EPCR1201-2**

- **CR circuit module**

This product is effective to suppress the surge which occurs in a relay contact part. Use it to protect the contacts of the relay or switch.

Four pieces of CR circuit for surge suppression are mounted on the compact circuit, and this product can be installed to the DIN rail. This product can make the wiring easily and securely since it also supports terminal block connection.

Model: **VCS02**

## 12-2 Regeneration resistor

If a vertical drive such as gravitational operation is performed or if sudden start-stop operation of a large inertia is repeated frequently, connect the regeneration resistor.

Model: **RGB200**

# 13 Appendix

## 13-1 Timing chart

### ■ Power ON

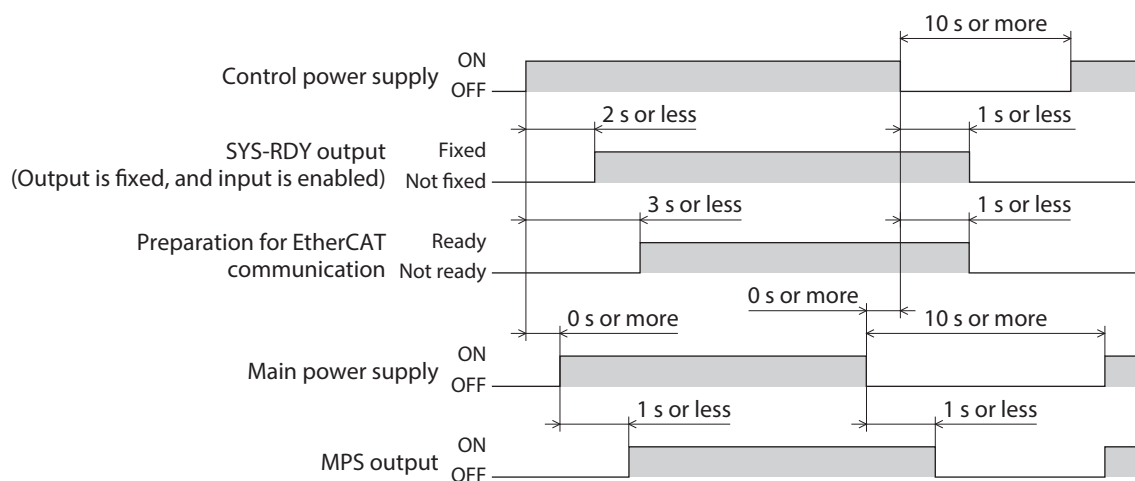

## 13-2 Specifications

### ■ Product specifications

#### ● Power supply

Power supply type	Item	Product model to be combined		
		AZXM640 AZXM940	AZXM960 AZXM1260 DGM200	AZXM1075 AZXM1175
Main power supply	Input voltage	<ul style="list-style-type: none"> <li>• Three-phase 200-240 VAC -15 to +6 % 50/60 Hz</li> <li>• Single-phase 200-240 VAC -15 to +6 % 50/60 Hz</li> </ul>		
	Rated current	<ul style="list-style-type: none"> <li>• Three phase: 3.0 A*1</li> <li>• Single-phase: 5.3 A*1</li> </ul>	<ul style="list-style-type: none"> <li>• Three phase: 3.9 A*1</li> <li>• Single-phase: 7.1 A*1*2</li> </ul>	<ul style="list-style-type: none"> <li>• Three phase: 4.8 A*1</li> <li>• Single-phase: 8.7 A*1</li> </ul>
Control power supply	Input voltage	24 VDC±5 %		
	Input current	0.27 A (0.57 A)*3	0.27 A (0.62 A)*3	0.27 A

\*1 It is the value when operated in the continuous duty region (region that can be used in continuous rating). When operated in the limited duty region (region that is used for acceleration and deceleration), the following current flows.

Main power supply	AZXM640 AZXM940	AZXM960 AZXM1260	DGM200	AZXM1075 AZXM1175
Three-phase	Up to approximately three times the current flow	Up to approximately four times the current flow	Up to approximately twice the current flow	Up to approximately 1.4 times the current flow
Single-phase		Up to approximately twice the current flow		

\*2 The limited duty region is restricted. Refer to the brochure for details.

\*3 The value in parentheses ( ) is the one when the electromagnetic brake motor is connected.

## ● Interface

Control input	Number of input points: 6, photocoupler
Pulse output	Number of output points: 2, line driver
Control output	Number of output points: 6, photocoupler, open collector
Power removal signal input	Number of input points: 2, photocoupler
Power removal monitor output	Number of output points: 1, photocoupler, open collector
Field network	EtherCAT

## ■ General specifications

Item		Product model to be combined		
		AZXM640 AZXM940	AZXM960 AZXM1260 DGM200	AZXM1075 AZXM1175
Operating environment	Ambient temperature	0 to +55 °C (+32 to +131 °F) (non-freezing)*	<ul style="list-style-type: none"> <li>When the main power supply is three-phase 200-240 VAC 0 to +55 °C (+32 to +131 °F) (non-freezing)*</li> <li>When the main power supply is single-phase 200-240 VAC 0 to +50 °C (+32 to +122 °F) (non-freezing)*</li> </ul>	<ul style="list-style-type: none"> <li>When the main power supply is three-phase 200-240 VAC 0 to +55 °C (+32 to +131 °F) (non-freezing)*</li> <li>When the main power supply is single-phase 200-240 VAC 0 to +40 °C (+32 to +104 °F) (non-freezing)*</li> </ul>
	Humidity	85 % or less (non-condensing)		
	Altitude	Up to 1,000 m (3,300 ft.) above sea level		
	Surrounding atmosphere	No corrosive gas or dust. No exposure to water or oil.		
Storage environment Shipping environment	Ambient temperature	-25 to +70 °C (-13 to +158 °F) (non-freezing)		
	Humidity	85 % or less (non-condensing)		
	Altitude	Up to 3,000 m (10,000 ft.) above sea level		
	Surrounding atmosphere	No corrosive gas or dust. No exposure to water or oil.		
Degree of protection		IP10		
Insulation resistance		100 MΩ or more when 500 VDC megger is applied between the following places: <ul style="list-style-type: none"> <li>Protective Earth Terminal - Main power supply input terminal</li> <li>Encoder connector - Main power supply input terminal</li> <li>I/O signal connector - Main power supply input terminal</li> </ul>		
Dielectric strength		Sufficient to withstand the specified voltage applied between the following places for 1 minute: <ul style="list-style-type: none"> <li>Protective Earth Terminal - Main power supply input terminal 1.5 kVAC 50/60 Hz</li> <li>Encoder connector - Main power supply input terminal 1.8 kVAC 50/60 Hz</li> <li>I/O signal connector - Main power supply input terminal 1.8 kVAC 50/60 Hz</li> </ul>		

\* When installing a driver on a heat sink [material: aluminum, 200×200×2 mm (7.87×7.87×0.08 in.) equivalent].



## 13-3 Regulations and standards

### ■ UL Standards, CSA Standards

This product is recognized by UL under UL and CSA Standards.  
It is not provided with the motor overtemperature protection specified in UL and CSA Standards.

### ■ CE Marking / UKCA Marking

This product is affixed with the marks under the following directive/regulations.  
Declaration of Conformity can be downloaded from Download Page of the product in Oriental Motor Website (<https://www.orientalmotor.eu/>).

### ● EU Low Voltage Directive / UK Electrical Equipment (Safety) Regulation

#### Installation conditions

Overvoltage category	II
Pollution degree	2
Degree of protection	IP10
Protection against electric shock	Class I

- This product cannot be used in IT power distribution systems.
- Isolate the motor cable, the power supply cable and other drive cables from the signal cables by means of double insulation.
- The temperature of the driver's heat sink may exceed 90 °C (194 °F) depending on the driving condition. Observe the followings.
  - Be sure to perform test operation and check the driver temperature.
  - Do not use the driver near combustible materials.
  - Do not touch the driver while operating.
- Use a circuit breaker conforming to EN or IEC Standards.
- The driver is not provided with the motor overtemperature protection specified in EN Standards.
- The driver is provided with the electronic motor overload protection specified in EN Standards. The time when the overload alarm is detected varies depending on the load factor.

Load factor (%)	Overload alarm detection time
100	Not detected
125	About 10 s
150	About 4 s
250	About 1 s
300	About 0.5 s
375	About 0.3 s

- Overload alarm detection time (reference)

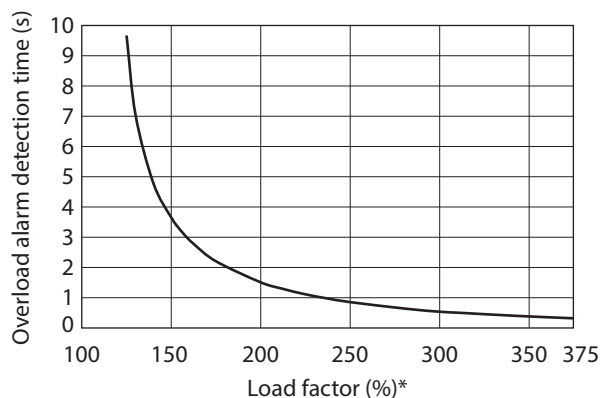

\* This indicates the motor output power presently generated as a percentage of the maximum output power in the continuous duty region.



The driver is equipped with the electronic motor overload protection, but not with the thermal retention function and the speed sensitive function.

- The driver is not equipped with the ground fault protection circuit. Wire the product in accordance with "Example of wiring to power supply considering ground fault protection" on p.50. Also observe the followings.
  - Earth leakage breaker: Rated current 15 A, rated sensitivity current 30 mA
  - When connecting to a power supply of Overvoltage category III, use an insulation transformer to ground its secondary side (N for single-phase, neutral point for three-phase).
  - Fault loop impedance: 1,000 Ω (Single-phase or three-phase Delta connection)  
577 Ω (Three-phase Star connection)

**Example of wiring to power supply considering ground fault protection**

**Single-phase 200 to 240 VAC**

- TN power distribution systems

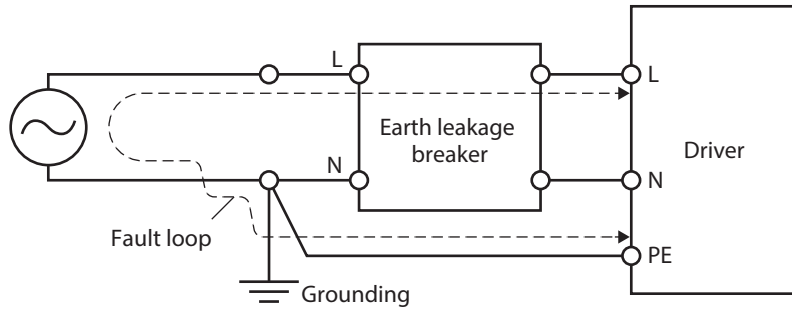

- TT power distribution systems

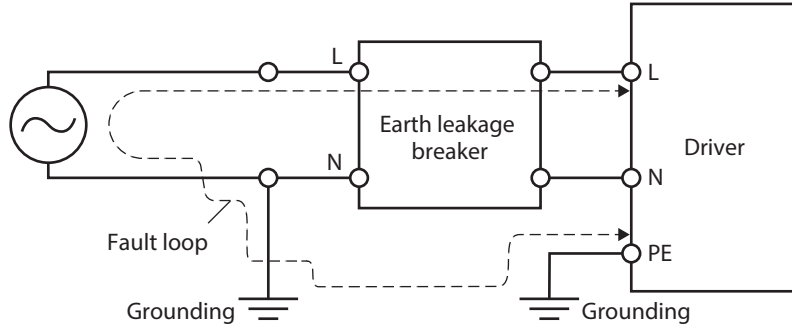

**Three-phase 200-240 VAC**

- TN power distribution systems

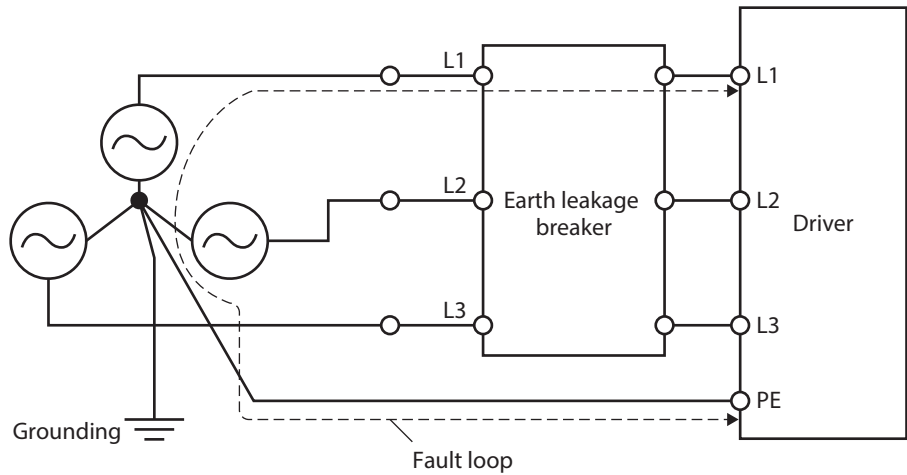

- TT power distribution systems

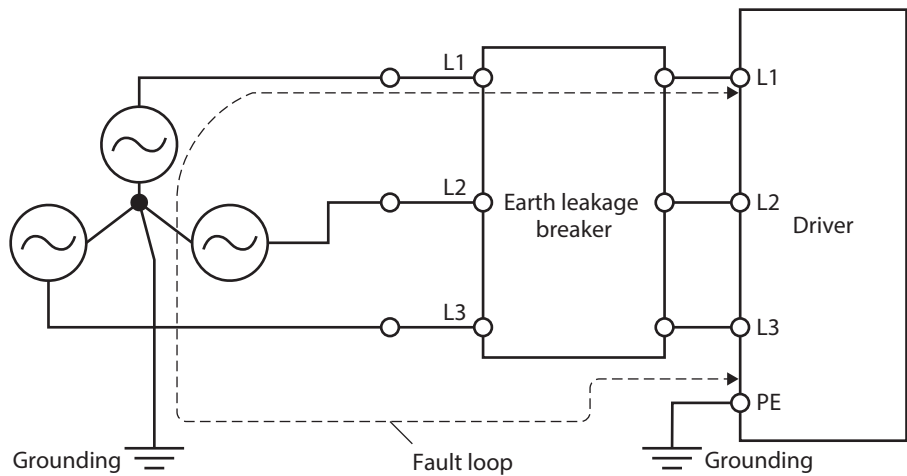

- **EU EMC Directive / UK EMC Regulations**

Refer to “8-9 Compliance with EMC Directive/Regulations” on p.28 for details on compliance.

- **EU Machinery Directive / UK Machinery Regulations**

Applicable standards: EN ISO 12100, EN 61800-5-2, EN ISO 13849-1: 2023

- **EU RoHS Directive / UK RoHS Regulations**

This product does not contain the substances exceeding the restriction values.

- **Functional safety**

This product is certified by TÜV SÜD Product Service GmbH under the following standards and affixed with the TÜV SÜD Mark. It is not a certified product if the TÜV SÜD Mark is not affixed.

Applicable standards	Functional safety	IEC 61800-5-2, EN 61800-5-2 IEC 61508-1, EN 61508-1 IEC 61508-2, EN 61508-2 ISO 13849-1: 2023, EN ISO 13849-1: 2023
	Electrical safety	EN 61800-5-1
	EMC	IEC 61000-6-7, EN 61000-6-7
	Safety function	STO (Safe Torque Off)

- Unauthorized reproduction or copying of all or part of this manual is prohibited.  
If a new copy is required to replace an original manual that has been damaged or lost, please contact your nearest Oriental Motor sales office.
- Oriental Motor shall not be liable whatsoever for any problems relating to industrial property rights arising from use of any information, circuit, equipment or device provided or referenced in this manual.
- Characteristics, specifications and dimensions are subject to change without notice.
- While we make every effort to offer accurate information in the manual, we welcome your input. Should you find unclear descriptions, errors or omissions, please contact the nearest office.
- **Oriental motor** is a registered trademark or trademark of Oriental Motor Co., Ltd., in Japan and other countries.  
EtherCAT® is a registered trademark and patented technology, licensed by Beckhoff Automation GmbH, Germany.  
Other product names and company names mentioned in this manual may be registered trademarks or trademarks of their respective companies and are hereby acknowledged. The third-party products mentioned in this manual are recommended products, and references to their names shall not be construed as any form of performance guarantee. Oriental Motor is not liable whatsoever for the performance of these third-party products.

© Copyright ORIENTAL MOTOR CO., LTD. 2023

Published in December 2024

- Please contact your nearest Oriental Motor office for further information.

ORIENTAL MOTOR U.S.A. CORP.  
Technical Support Tel:800-468-3982  
8:30am EST to 5:00pm PST (M-F)

ORIENTAL MOTOR (EUROPA) GmbH  
Schiessstraße 44, 40549 Düsseldorf, Germany  
Technical Support Tel:00 800/22 55 66 22

ORIENTAL MOTOR (UK) LTD.  
Unit 5 Faraday Office Park, Rankine Road,  
Basingstoke, Hampshire RG24 8QB UK  
Tel:+44-1256347090

ORIENTAL MOTOR (FRANCE) SARL  
Tel:+33-1 47 86 97 50

ORIENTAL MOTOR ITALIA s.r.l.  
Tel:+39-02-93906347

ORIENTAL MOTOR ASIA PACIFIC PTE. LTD.  
Singapore  
Tel:1800-842-0280

ORIENTAL MOTOR (MALAYSIA) SDN. BHD.  
Tel:1800-806-161

ORIENTAL MOTOR (THAILAND) CO., LTD.  
Tel:1800-888-881

ORIENTAL MOTOR (INDIA) PVT. LTD.  
Tel:1800-120-1995 (For English)  
1800-121-4149 (For Hindi)

TAIWAN ORIENTAL MOTOR CO., LTD.  
Tel:0800-060708

SHANGHAI ORIENTAL MOTOR CO., LTD.  
Tel:400-820-6516

INA ORIENTAL MOTOR CO., LTD.  
Korea  
Tel:080-777-2042

ORIENTAL MOTOR CO., LTD.  
4-8-1 Higashiueno, Taito-ku, Tokyo  
110-8536 Japan  
Tel:+81-3-6744-0361  
[www.orientalmotor.co.jp/ja](http://www.orientalmotor.co.jp/ja)