

## Small Robots OVR

# 4-axis Vertically Articulated OVR4048K5-V/OVR4068K5-V/ OVR4088K5-V

## Technical Reference

---

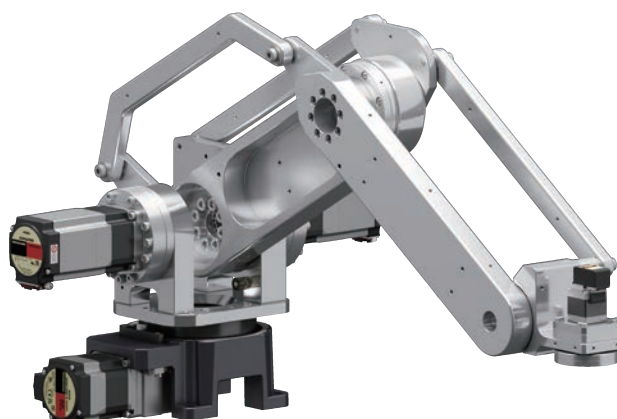

### Table of contents

1	Introduction .....	2	6	Before starting operation .....	15
2	Safety precautions .....	3	7	Maintenance.....	19
3	Preparation .....	6	8	Specifications .....	20
4	Installation.....	9			
5	Connection .....	13			

---

Thank you for purchasing an Oriental Motor product.  
This document describes product handling procedures and safety precautions.

- Please read it thoroughly to ensure safe operation.
- Always keep the document where it is readily available.

# 1 Introduction

---

## 1-1 Before use

Only qualified personnel of electrical and mechanical engineering should work with the product. Use the product correctly after thoroughly reading the "2 Safety precautions" on p.3. In addition, be sure to observe the contents described in warning, caution, and note in this document. The product described in this document is designed and manufactured to be incorporated in general industrial equipment. Do not use for any other purpose. Oriental Motor Co., Ltd. is not responsible for any compensation for damage caused through failure to observe this warning.

## 1-2 Related operating manuals

For operating manuals and technical reference, contact your nearest Oriental Motor sales office.

- Small Robots **OVR** 4-axis Vertically Articulated **OVR4048K5-V/OVR4068K5-V/OVR4088K5-V** technical reference (this document)
- **AZ** Series/Motorized actuator equipped with **AZ** Series OPERATING MANUAL Function Edition

## 1-3 Overview of the product

This product is a 4-axis vertically articulated robot consisting of **AZ** series/**AZ** series equipped hollow rotary actuator equipped with a battery-free absolute sensor. Automation can be achieved without the hassle of design, component selection, and processing. When using it, please pay attention to safety aspects as an industrial robot. It cannot be used as a collaborative robot. The product target is the robot (including the motor). Host controllers, drivers, cables, end effectors, etc. are sold separately. Please contact us for control aspects.





## 2 Safety precautions

The precautions described below are intended to ensure the safe and correct use of the product, and to prevent the customer and others from exposure to the risk of injury. Use the product only after carefully reading and fully understanding these instructions.

In regard to a robot, it is prohibited to start operating the robot (i.e., to operate the device in accordance with the specified purpose) when the machine in which the robot is incorporated does not satisfy any relevant safety standards.

The factory safety manager or safety personnel in charge of the applicable machine must ensure that the machine is operated only by qualified personnel who are familiar with the operation of electronic equipment, and thereby prevent injury or damage to the equipment.

The term "qualified personnel" refers to persons who have received the necessary training or education and have pertinent experience; who are familiar with the relevant standards, regulations, accident-prevention rules and inspection conditions; who are authorized by the factory safety manager to engage in the necessary activities; and who have the ability to discern and prevent potential dangers.

 <b>WARNING</b>	Handling the product without observing the instructions that accompany a "WARNING" symbol may result in death or serious bodily injury.
 <b>CAUTION</b>	Handling the product without observing the instructions that accompany a "CAUTION" symbol may result in bodily injury or property damage.
 <b>Note</b>	The items under this heading contain important handling instructions that the user should observe to ensure the safe use of the product.
 <b>memo</b>	The items under this heading contain related information and contents to gain a further understanding of the text in this document.

### **WARNING**

#### General

- Never use the product for equipment in connection with the maintenance or management of human life or health.
- Do not use the product in explosive or corrosive environments, in the presence of flammable gases, in places subjected to splashing water, or near combustibles. Doing so may result in fire or injury.
- Assign qualified personnel having expert knowledge on electrical and mechanical engineering as well as safety to the task of installing, wiring, operating/controlling, inspecting and troubleshooting the product. Handling by unqualified personnel may result in fire, injury, or damage to equipment.
- Do not install, wire, inspect and troubleshoot the product while the power is on. When working while the power is on, take appropriate safety measures. Failure to do so may result in fire, injury, or damage to equipment.
- Be careful not to get your hands caught in the moving parts of the product. Doing so may result in injury or damage to equipment.
- Do not disassemble or modify the product. Doing so may result in injury or damage to equipment.
- Conduct a risk assessment in a state where all parts and components including the robot have been installed in the equipment. Failure to do so may result in injury or damage to equipment.
- Use the product in a condition where the entire equipment complies with relevant international standards such as ISO 12100, ISO 10218-1, ISO 10218-2, national standards, and legal regulations such as occupational health and safety required in each country. Failure to do so may result in injury or damage to equipment.
- Provide a safety cage that satisfies the safety distance specified in ISO 13857 so that an operator or other personnel does not enter the movable range of the robot during operation of the equipment. Failure to do so may result in injury.
- Provide appropriate safety measures in accordance with the results of the risk assessment of entire equipment when adjusting or inspecting the robot inside the safety cage. Failure to do so may result in injury.
- Provide appropriate safety measures so that the entire equipment will operate safely in the event of a system failure or malfunction. Failure to do so may result in injury.
- The functions and performance of safety-related control systems shall be determined appropriately according to the results of risk assessment of entire equipment. Failure to do so may result in injury.

#### Installation and wiring

- The product is heavy. Two or more people are required to transport and install the product. Failure to do so may result in injury.

- Wear protective equipment such as helmets, safety shoes, and gloves when transporting and installing. Failure to do so may result in injury.
- Do not pull or forcibly bend the arm or cable, or lift the product body by holding the arm or cable part. Doing so may result in injury or damage to equipment.
- The product body should be securely fixed according to the instructions. Failure to do so may result in injury or damage to equipment.
- Wiring and connection are done reliably according to the instructions. Failure to do so may result in fire or damage to equipment.
- To prevent fire caused by large current from the power supply side, install an external fuse as necessary.

### Operation

- When powering on the driver, make sure that no signal is input from the host controller. The product may start to move unintentionally, which may cause injury or damage to the equipment.
- When turning on the power to the driver for the first time, be sure to copy the fixed parameter values of the ABZO sensor to the combined driver. Otherwise, there is a risk of unexpected behavior due to parameter mismatch. Failure to do so may result in injury or damage to the equipment.
- If any abnormality occurs with the product, immediately stop operation and cut off the power to the motor that drives the product. Failure to do so may result in injury or damage to the equipment.
- Do not input the driver's STOP-COFF (current off) signal while the product is in operation. When input, the motor stops and becomes unexcited, which may cause the holding force to disappear and cause unexpected movements. Doing so may cause injury or damage to the equipment.
- Do not input the driver's FREE (non-excitation) signal when the product is stopped or running. When this signal is input, the drive motor's current is cut off and it becomes non-excitation, losing its holding force. At the same time, the power off activated type electromagnetic brakes is released, so the robot's own weight will cause it to lose its posture and the workpiece may fall. Doing so may cause injury or damage to the equipment.
- When cutting off motor power using an external cutoff device or the driver's STOP-COFF (current off) signal, take appropriate safety measures. The motor may lose torque and the product may move unexpectedly. Failure to do so may result in injury or damage to the equipment.
- During the first operation after turning on the power to the driver and cutting off power to the motor, adjust the position at low speed and confirm safety. Failure to do so may result in injury or damage to the equipment.
- In the event of a power outage, turn off the power to the driver. The product may suddenly start up when the power is restored, resulting in injury or equipment damage to equipment.

### Maintenance and inspection

- Perform pre-work (daily) inspections and periodic inspections in accordance with the instructions in the instruction manual and technical materials, and confirm that there are no abnormalities in the product and related equipment before starting work. Failure to do so may result in injury or damage to the equipment.
- If the motor needs replacing during maintenance, please contact your nearest Oriental Motor sales office.

## CAUTION

### General

- Do not use the product beyond its specifications. Doing so may result in injury or damage to equipment.
- Use the driver and cable connected to the motor in the specified combination. Failure to do so may cause fire, injury, or equipment damage.
- When connecting the motor and driver, be careful not to mix them up incorrectly. Incorrect wiring may result in unexpected operation. This may cause injury or damage to the equipment.
- Keep the area around the product free of combustible materials. Failure to do so may result in fire or a skin burn(s).
- Do not leave anything around the product that would obstruct ventilation. Failure to do so may result in damage to equipment.
- When conducting the insulation resistance measurement or the dielectric strength test, be sure to separate the connection between the product and the driver. Failure to do so may result in damage to the equipment.
- When installing and wiring, take measures against EMC. Failure to take effective measures against EMI from the product and driver to the surrounding control system equipment, as well as the EMS of the product and driver, can cause serious damage to the functioning of the equipment.
- When handling, take measures such as static electricity. The encoder (ABZO sensor) or driver of the motor that drives the product may malfunction or be damaged due to static electricity, etc. Failure to do so may result in injury or damage to the equipment.
- Do not move the encoder (ABZO sensor) toward a strong magnetic field. Doing so may cause damage to the encoder (ABZO sensor) or malfunction of the product. Doing so may cause injury or damage to the equipment.
- If abnormal sound or vibration occurs during operation, stop operation. Failure to do so may result in injury or damage to the equipment.

- The status of the operation control device should be clearly displayed, for example, “power on,” “malfunction (failure) detected,” or “automatic operation.” If an indicator light is used, it should be installed in a suitable position and the color should conform to IEC 60204-1.
- The motor surface temperature may exceed 70 °C (158 °F) even under normal operating conditions. If the operator is allowed to approach the motor in operation, affix a warning label shown in the figure on a conspicuous position. Failure to do so may result in a skin burn(s).
- To protect the encoder (ABZO sensor), use the motor at the case surface temperature of 80 °C (176 °F) or less. Failure to do so may result in damage to the equipment.
- Do not subject the encoder (ABZO sensor) of the motor to strong impact. Damage to the encoder (ABZO sensor) may cause the product to malfunction, resulting in injury or damage to equipment. The label shown in the diagram is attached to the motor.
- Be careful not to get your fingers caught in the stoppers (three place) that restricts the movement of the product’s L-axis (M2: lower arm) and U-axis (M3: upper arm). Failure to do so may cause injury. The label shown in the figure is attached to the stopper.



Warning label



Warning label



Warning label

# 3 Preparation

## 3-1 Checking the product

Verify that the items listed below are included. Report any missing or damaged items to the Oriental Motor sales office from which you purchased the product.

- Robot ..... 1 unit
- Positioning pin ..... 1pc.
- Washers.....4pc. \***OVR4088** only
- Unpacking instructions..... 1 copy

## 3-2 How to identify the product model

Check the model against the model shown on the nameplate.

**OVR** **4** **068** **K** **5** - **V**  
 1      2      3      4      5

1	Number of axes	<b>4</b> : 4-axis
2	Reach length	<b>048</b> : 480 mm (18.90 in.) <b>068</b> : 680 mm (26.77 in.) <b>088</b> : 880 mm (34.65 in.)
3	Power supply input	<b>K</b> : 24 VDC
4	Payload	<b>5</b> : 5 kg (11 lb.)
5	Robot type	<b>V</b> : Vertically articulated

## 3-3 Drivers possible to combine

Series	Driver type	Model
<b>AZ Series</b>	Built-in controller type	<b>AZD-KD</b>
	mini Driver RS-485 communication type	<b>AZD-KR2D</b>

## 3-4 Information about nameplate

The figure shows an example.

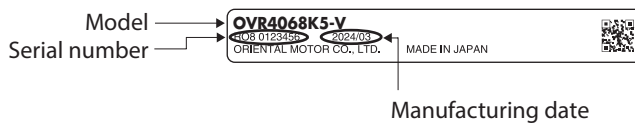

## 3-5 Names and functions of parts

The robot consists of four axes: S-axis (M1: swing), L-axis (M2: lower arm), U-axis (M3: upper arm), and R-axis (M4: wrist rotation).

- All drive motors are **AZ** series equipped with battery-free absolute sensors.
- The motors on the L-axis (M2: lower arm) and U-axis (M3: upper arm) are equipped with the power off activated electromagnetic brake type.

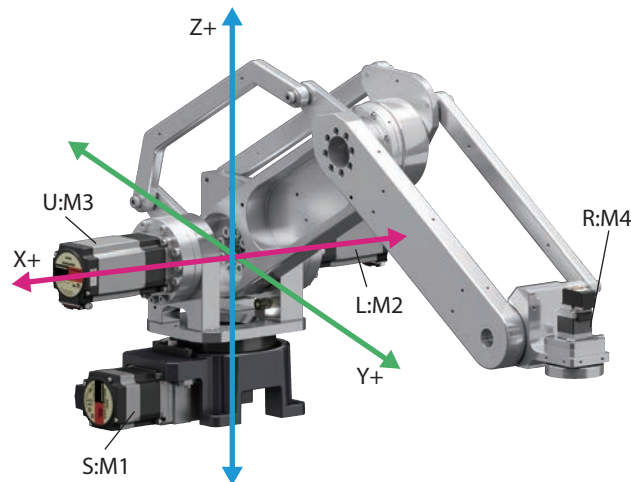

### • OVR4048/4068

Axis	Axis name	Model
S-axis	M1	<b>DGB130R36-AZAKL</b>
L-axis	M2	<b>AZM66MKH,</b> <b>CSG25-100-2UH-LW-SP-A</b> (Harmonic Drive Systems Inc.)
U-axis	M3	<b>AZM66MKH,</b> <b>CSG20-100-2UH-LW-SP-B</b> (Harmonic Drive Systems Inc.)
R-axis	M4	<b>AZM24AK,</b> <b>CSF-8-50-2UP-SP-A</b> (Harmonic Drive Systems Inc.)

### • OVR4088

Axis	Axis name	Model
S-axis	M1	<b>AZM66A0KH,</b> <b>HPN-14A-03-J6AEA-YB1-OM</b> (Harmonic Drive Systems Inc.), <b>RGV063-012GT-VN</b> (Sankyo Seisakusho Co.)
L-axis	M2	<b>AZM66MKH,</b> <b>CSG25-100-2UH-LW-SP-A</b> (Harmonic Drive Systems Inc.)
U-axis	M3	<b>AZM66MKH,</b> <b>CSG20-100-2UH-LW-SP-B</b> (Harmonic Drive Systems Inc.)
R-axis	M4	<b>AZM24AK,</b> <b>CSF-8-50-2UP-SP-A</b> (Harmonic Drive Systems Inc.)

**Relationship between coordinates and rotation direction**

Axis	Coordinate	Rotation direction
S-axis (M1: swing)	+Y	CCW
	-Y	CW
L-axis (M2: lower arm)	+X	CCW
	-X	CW
U-axis (M3: upper arm)	+Z	CCW
	-Z	CW
R-axis (M4: wrist rotation)	+RY	CCW
	-RY	CW

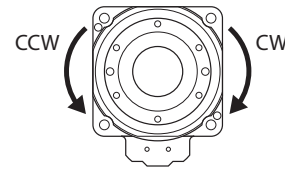

- Note**
- S-axis (M1): The rotation direction of the hollow rotary actuator is the direction seen from the mounting surface of the rotating part.
  - L-axis (M2), U-axis (M3), R-axis (M4): For harmonic geared types, the direction is the direction seen from the opposite output shaft of the **AZ** motor.

**3-6 Rotation limiting mechanical stopper**

The mechanical stoppers are included to limit the range of motion of the robot. When in use, set software limits for each axis to avoid direct contact with the mechanical stopper during teaching or operation.

- Note**
- The S-axis (M1: swing) motor does not have an electromagnetic brake. When the power is turned off, the output shaft becomes free. Please, handle with care.
  - The motors on the L-axis (M2: lower arm) and U-axis (M3: upper arm) are equipped with the power off activated type electromagnetic brakes. Do not input the driver's FREE (non-excitation) signal when the product is stopped or running. When this signal is input, the drive motor's current is cut off and it becomes non-excitation, losing its holding force. At the same time, the power off activated type electromagnetic brakes is released, so the robot's own weight will cause it to lose its posture and the workpiece may fall.
  - The rotation limiting stoppers for the L-axis (M2: lower arm) and U-axis (M3: upper arm) are not intended to protect against dropping. Please ensure safety before using.

**Rotation limiting mechanical stoppers**

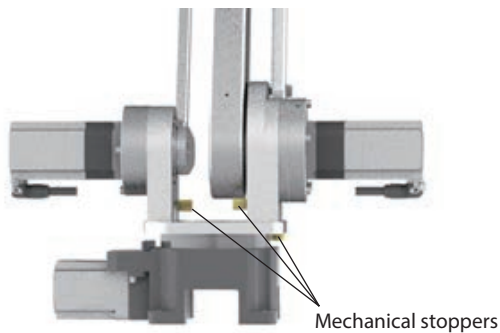



# 4 Installation

## 4-1 Installation location

The product is designed and manufactured to be incorporated in general industrial equipment. Install it in a well-ventilated location that provides easy access for inspection. The location must also satisfy the following conditions:

- Inside an enclosure that is installed indoors (provide vent holes)
- Operating ambient temperature: 0 to +40 °C [+32 to +104 °F] (non-freezing)
- Operating ambient humidity: 85 % or less (non-condensing)
- Area free of explosive atmosphere, toxic gas (such as sulfuric gas), or liquid
- Area not exposed to direct sun
- Area free of excessive amount of dust, iron particles or the like
- Area not subject to splashing water (rain, water droplets), oil (oil droplets) or other liquids
- Area free of excessive salt
- Area not subject to continuous vibration or excessive shocks
- Area free of excessive electromagnetic noise (from welders, power machinery, etc.)
- Area free of radioactive materials, magnetic fields or vacuum
- Up to 1,000 m (3,300 ft.) above sea level

## 4-2 How to unpack



- Wear protective equipment (helmet, safety shoes, safety glasses, gloves) when working.
- The product is heavy [approximately 16.5 to 26.9 kg (36.3 to 59.2 lb.)], so two or more people are required to transport and install it.

1. Place the box on a horizontal, flat surface and unpack it. The product is not fixed to the box and there is a risk of the product tipping over, so please be careful when handling.



2. Take out the product. When removing it, be sure to hold the L-axis motor part and the U-axis motor part with both hands. When doing this, try to hold the motor by its output shaft side as much as possible, without holding the motor connector. If you hold the product incorrectly, such as by holding it with one hand or only by the arm, the arm may move in an unexpected direction, resulting in a fall or injury.



3. Place the product in the installation location and remove the packaging materials.

## 4-3 Installation method

**Note**

- Ensure that the installation location has enough work space to safely perform teaching and maintenance inspections.
- When installing the product, install a safety cage to prevent it from entering the product's movable range.
- Perform a risk assessment of the entire equipment before use to ensure that there is no contact with the product within the cage and that it is safe please.

● **OVR4048/4068**

Fix it using the positioning pin hole and mounting hole of the hollow rotary actuator (**DGB130R36-AZAKL**) of the S-axis (M1: swing).

Please fix it firmly according to the installation specifications.

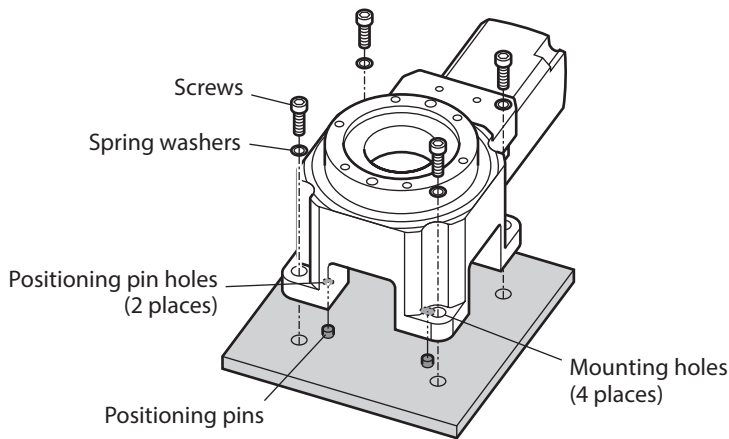

**Note**

- Be sure to install the hollow rotary actuator (**DGB130R36-AZAKL**) from the upper side of the mounting plate. It cannot be installed from below the mounting plate.
- When installing the product, do so in a stable condition so that the product does not tilt.
- Please periodically check that the screws are not loose.

● **OVR4088**

Fix it using the mounting hole of the S-axis (M1: swing). Please fix it firmly according to the installation specifications. Use the provided washers.

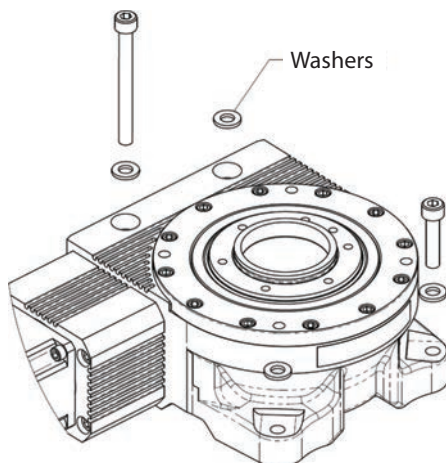

Washer Specifications

- Outside diameter: 16 mm (0.63 in.)
- Thickness: 2 mm (0.08 in.)

**Note**

- When installing the product, do so in a stable condition so that the product does not tilt.
- Please periodically check that the screws are not loose.

## ■ Installation specifications

### ● OVR4048/4068

#### Mounting plate specifications

Thickness	10 mm (0.39 in.) or more
Material	Steel

#### Specifications for mounting holes and positioning pin holes

Provide screw hole machining in the mounting plate. When positioning the product, use the two positioning pin holes. Values of the tightening torque are recommended. Tighten the screws with a suitable torque according to the design conditions of the mounting plate.

Mounting holes	Hole diameter	ø9 mm (ø0.35 in.)
	Nominal size	M8
	Tightening torque	13 N·m (115 lb-in)
Positioning pin holes	Pin hole diameter	ø5 <sup>+0.012</sup> <sub>0</sub> mm (ø0.1969 <sup>+0.0005</sup> <sub>0</sub> in.)
	Pin hole depth	5 mm (0.20 in.), Blind hole

#### Viewing from the opposite side to the output table

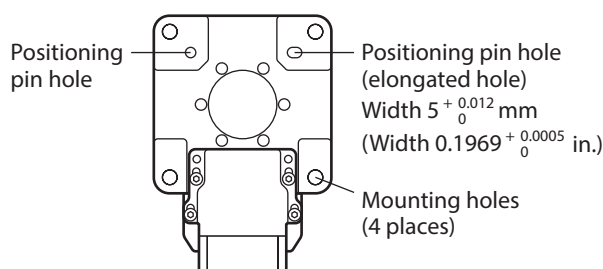

- To prevent vibration, install the product on a metal surface of sufficient strength.
- The outline drawing of the hollow rotary actuator (**DGB130R36-AZAKL**) can be downloaded from the Oriental Motor website.

### ● OVR4088

#### Mounting plate specifications

Thickness	10 mm (0.39 in.) or more
Material	Steel

#### Specifications for mounting holes and positioning pin holes

Provide screw hole machining in the mounting plate. Values of the tightening torque are recommended. Tighten the screws with a suitable torque according to the design conditions of the mounting plate.

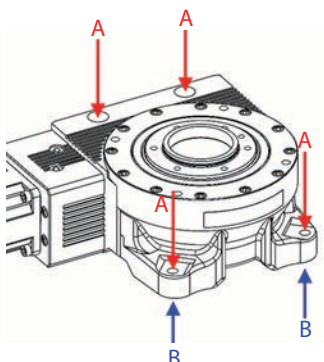

	A	B
Nominal size	M8	M10
Tightening torque	18.5 N·m (163 lb-in)	36.0 N·m (310 lb-in)

Viewing from the opposite side to the output table [Unit: mm]

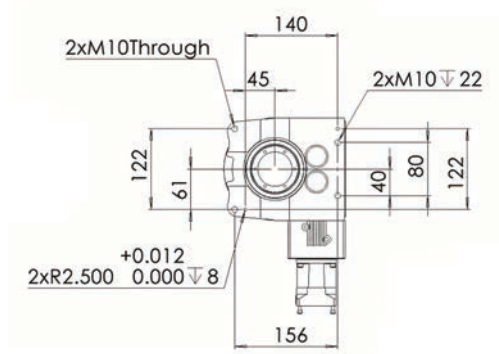

**Note** To prevent vibration, install the product on a metal surface of sufficient strength.

■ **Installing a load**

Install a load with screws using the load-mounting screw holes (four places) onto the output table.

Use the load-mounting pin holes (three places) of the output table when positioning a load.

Values of the tightening torque are recommended. Tighten the screws with a suitable torque according to the design conditions of the load.

Nominal size	M5
Tightening torque	5 N•m (710 oz-in)
Effective depth of screw thread	6.5 mm (0.26 in.)
Material of load	Steel or aluminum
Pin hole diameter	$\varnothing 5^{+0.012}_0$ mm ( $\varnothing 0.1969^{+0.0005}_0$ in.)
Pin hole depth	6.5 mm (0.26 in.), Blind hole

**Mounting face of R-axis (M4: wrist rotation) [Unit: mm (in.)]**

Compliant with ISO 9409-1-31.5-4-M5

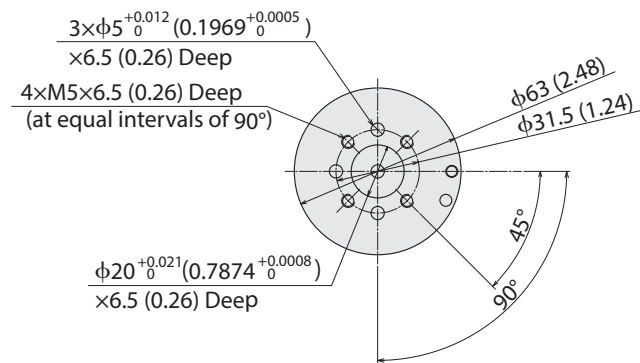

## 5 Connection

---

- Fix the area near the connector so that it does not move.
- Keep 10 m (32.8 ft.) or less for the wiring distance between a motor and a driver.

### ■ Wiring example

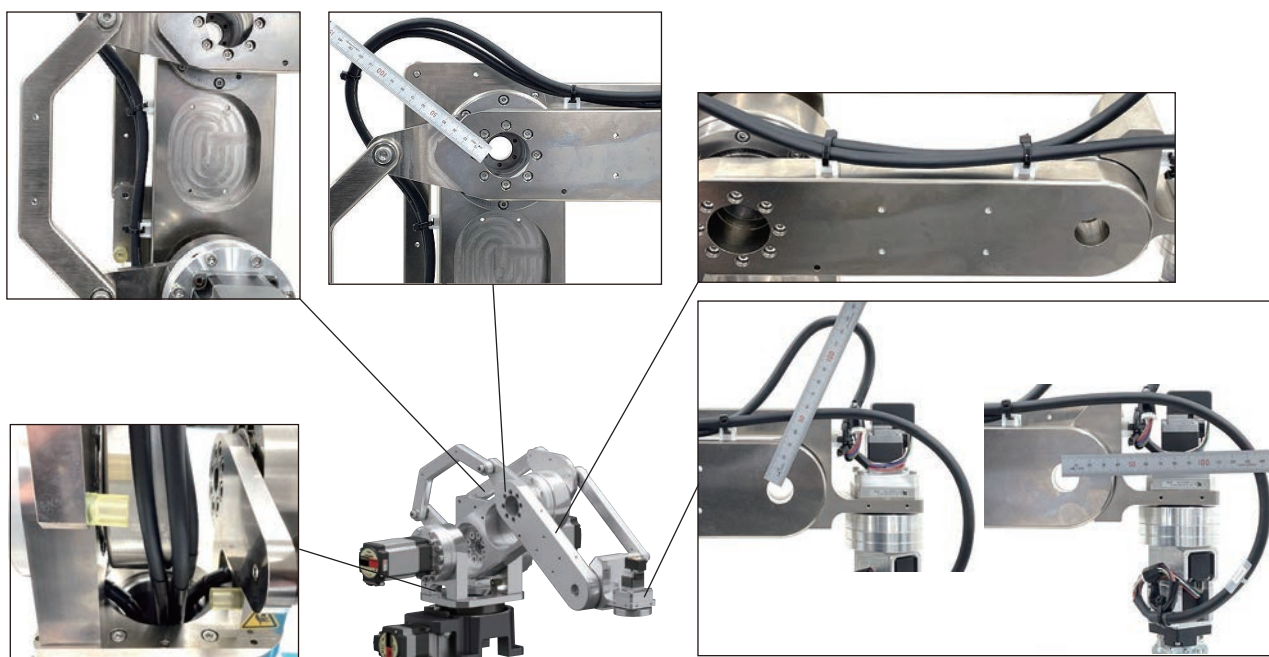
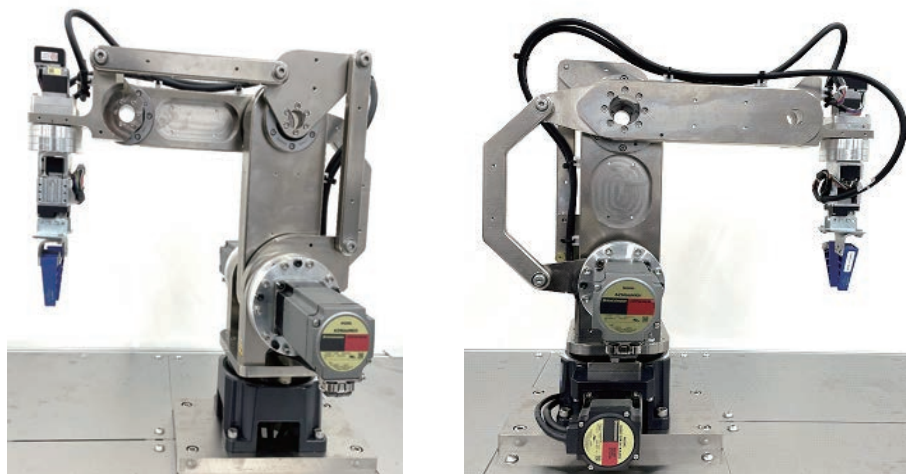

## ■ Connecting the cable

M2 and M3 (**OVR4088** is M1 to M3) are connector type motors. Please check the connection method below.

1. Remove the connector cap.

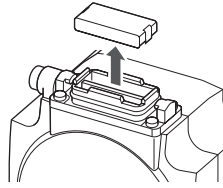

**Note** Do not damage the O-ring of the connector when removing the connector cap.

2. Connect the connector of the connection cable. The figure shows an example using the connection cable of cable outlet in output shaft direction. Check the terminal position of the connector before connecting.

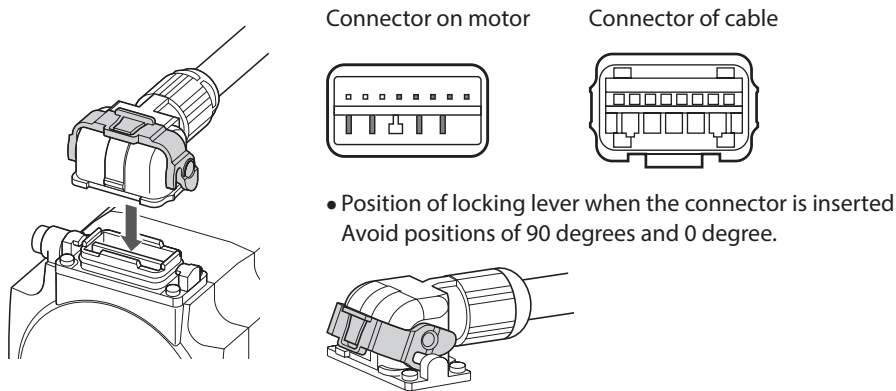

**Note** If the locking lever is in a state of being turned up to the 90-degree position or down to the 0-degree position, parts around the locking lever and the connector contact with each other, and the connector cannot be connected.

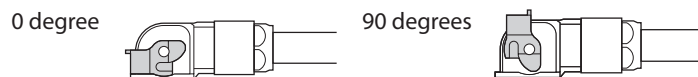

3. Turn down the locking lever to the 0-degree position to fix the connector.

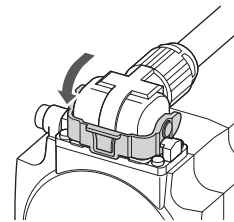

### Handling of locking lever

- Do not apply a strong force to the locking lever. If the locking lever is damaged, the connector may not be fixed securely.
- After connecting the connector, securely turn down the locking lever to the 0-degree position to fix the connector.

**⚠ WARNING** Be sure to turn down the locking lever. If the connector is not fixed, the cable may come off, resulting in fire, electrical shock, or damage to equipment.

### Detaching the cable

Turn up the locking lever and pull out the connector.

**memo** Turning up the locking lever to the 90-degree position will detach the connector at the same.

## 6 Before starting operation

- This product drives the robot (4-axis) with **AZ** series DC power input type drivers (4 units).
- Host controller equipment, drivers, cables, end effectors, etc. are sold separately.
- Connect between drivers using RS-485 communication. You can set operating data and parameters, and input operating commands using RS-485 communication. The protocol supports Modbus (RTU) and can be connected to touch panels, PCs, etc. For operating manual of the driver, download from Oriental Motor Website Download Page or contact your nearest Oriental Motor sales office.

### 6-1 System configuration

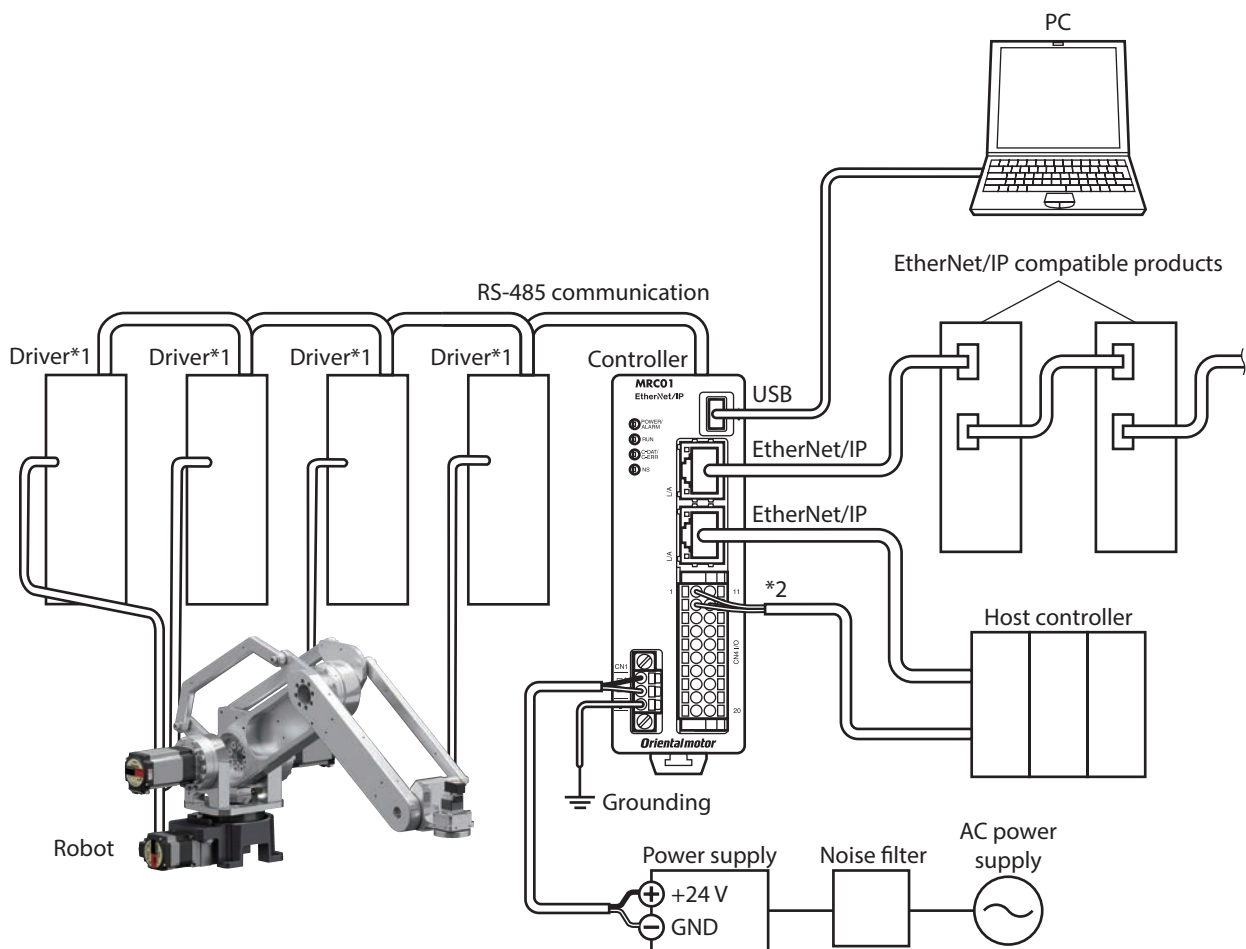

\*1 Connect a power supply to each driver.

\*2 Connect when using direct I/O or sensors.

**Note** If the motor cable or the power supply cable generates an undesirable amount of noise depending on the wiring or configuration, shield the cable or install a ferrite core.

## 6-2 Copying the fixed value (parameter) of the ABZO sensor to a driver

- For parameters of the **AZ** Series, the different values are stored in the ABZO sensor and driver. When turning on the driver for the first time, copy the ABZO information (fixed value) parameter to the driver using support software **MEXE02**.
- The hollow rotary actuator of the S-axis (M1: swing) has parameters unique to the ABZO sensor stored. If you change the **AZ** series parameters with **MEXE02** without copying the fixed values (parameter) of the ABZO sensor to the driver, depending on the parameters, electronic gear settings etc. may be changed and unexpected movements may occur. In order to prevent such problems, copy the ABZO information (fixed value) to the driver, and match the data in the driver parameter with the fixed value in the ABZO sensor.
- Be sure to create a recovery data file before installing the product. The recovery data file is a file that information of the factory setting is stored. At the beginning, create the recovery data file for when the product is replaced with maintenance or the product is malfunctioned. Save the recovery data file in a PC as a data file.
- For details on how to copy the fixed values (parameters) of the ABZO sensor to the driver and how to create a recovery data file, please refer to the "**AZ** Series OPERATING MANUAL Function Edition".



- After writing the parameter (example: electronic gear, etc.), which was changed to [Manual setting] and set, from the **MEXE02** to the driver, even if the ABZO information (fixed value) is copied, the parameter that was changed with the manual setting does not return to the fixed value.
- The work in "6-2 Copying the fixed value (parameter) of the ABZO sensor to a driver" is not necessary when using the robot controller **MRC01**. After completing setup with **MRC Studio**, we recommend backing up your data in case you need to replace the motor during maintenance. You can save data by selecting [Save As] from the **MRC Studio** [File] menu.

### ■ Procedure

1. Click the **MEXE02** [Communication] menu, and click the [Copy the ABZO (fixed) information to the driver in a lump.]

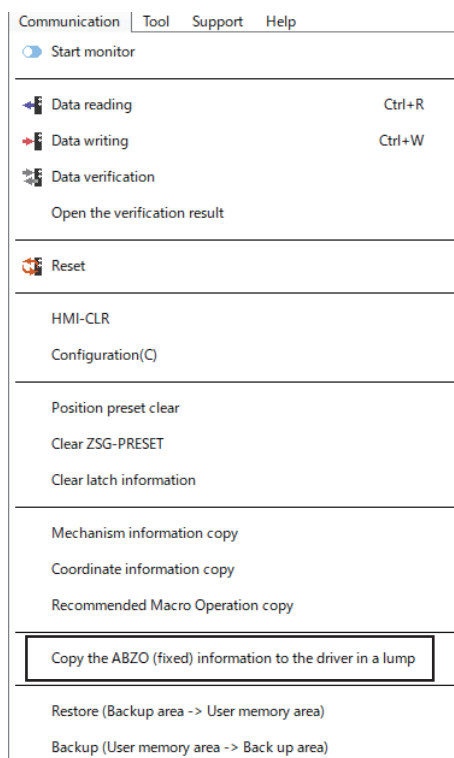

2. Click [Yes]. All ABZO information (fixed value) is copied in the driver.
3. After it is completed, click [OK].
4. Cycle the driver power.
5. Check whether the copied data is updated on the unit information monitor window.



## 6-3 Home position setting

- Home position setting is an operation to set the home position of each axis in order to use the product with high precision. The home position has not been set at the time of shipment. When using the product for the first time after unpacking or when replacing the driver, etc., be sure to determine the origin of the base coordinate system before use.
- This product has four positioning pin holes [ø4mm (ø0.16 in.)] for setting the origin (see the figure below). Can be used when setting the origin of the base coordinate system and the origin of the user coordinate system.
- When adjusting the position, move each axis slowly to a position where the positioning pin can be inserted. Adjust in the order of U-axis (M3: upper arm), L-axis (M2: lower arm), and R-axis (M4: wrist rotation). Each axis will be at a right angle.

**Note** When using the robot controller **MRC01**, it is not necessary to set the origin initially after unpacking.

### Positioning pin hole position for installation origin posture

Pin size: ø4mm [ø0.16 in.] (four places)

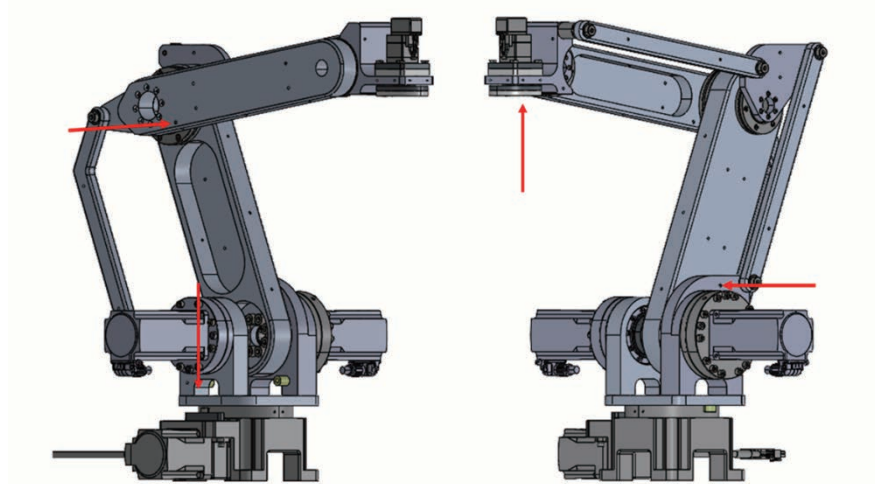

### ■ Procedure

**Note** Do not input the driver's FREE (non-excitation) signal when the product is stopped or running. When this signal is input, the drive motor's current is cut off and it becomes non-excitation, losing its holding force. At the same time, the power off activated type electromagnetic brakes is released, so the robot's own weight will cause it to lose its posture and the workpiece may fall.

#### ● When used in combination with MRC01

Set the information of the robot with the **MRC Studio** software. Once setup is complete, the origin of the base coordinate system is applied.

1. Start the **MRC Studio** software.
2. Click [COM port] to select "**MRC01**."
3. Click [Setup] on the start screen.
4. Set the robot type and the mechanism information according to the instructions on the screen.

#### ● When determining the origin for each axis

Determine the origin using support software **MEXE02**. For details on the setting method, please refer to "**AZ Series OPERATING MANUAL Function Edition**".

1. Start the **MEXE02** software.
2. Click [Teaching, remote operation].
3. Click the [Teaching, remote operation] checkbox.
4. Operate the motor till the home position using the JOG operation buttons. Adjust the position while checking the "Command position (CPOS)" in the "Driver status" field.
5. Click [Position preset]. The home position is set.

**Note**

- 
- The **AZ** series returns to origin using high-speed return-to-home operation. High-speed return-to-home operation is an operation to return to the mechanical home position on the absolute position coordinate set in advance. Since the home position is recognized by the ABZO sensor, return-to-home operation can be executed at the same speed as that of the normal positioning operation without using an external sensor. When performing high-speed return-to-home operation, be sure to follow "2 Safety precautions" on p.3, check the surrounding conditions, and ensure safety before performing the operation.
  - When the ZHOME input is turned ON, high-speed return-to-home operation is started. The motor stops when the operation stop signal is turned ON while the motor is operating.
  - The home position is not set at the time of factory shipment and immediately after the resolution is changed. If high-speed return-to-home operation is started under the status, information of ZHOME start error is generated, and operation is not performed. Be sure to set the home position before starting high-speed return-to-home operation.
-

# 7 Maintenance

Daily and periodic inspections should be carried out by workers with sufficient knowledge and experience in accordance with "2 Safety precautions" on p.3. Be sure to perform these inspections to prevent malfunctions and ensure safety, and confirm that there are no abnormalities in the product and related equipment before starting work. If you find any abnormality, please stop using it immediately and take any necessary repairs or other measures.

## 7-1 Inspection

### ■ Inspection interval

If the robot is operated eight hours a day, perform maintenance according to the applicable period specified in the table. Reduce maintenance intervals accordingly if the operating rate is high such as continuous operation for twenty-four hours.

Maintenance timing	Inspection	Cleaning
When operated for the first time	○	—
Six months after initial operation	○	—
Every six months thereafter	○	—
As needed	—	○

### ■ Inspection item

- Check if any of the screws having installed the product is loose.
- Check if any of the screws having installed a load is loose.
- Check if a damage or stress is applied on the cable.
- Check if the connection part between the motor and driver is loose.
- Check if an unusual noise or vibration is generated from a bearing part (ball bearings) when before and after turning on the power.
- Check if the operating position does not shift during return-to-home operation and during operation (original program operation).



- When carrying out each inspection, please record the inspection results and special notes on the daily inspection sheet.
- Perform inspections outside the moving range as much as possible.
- When repairs are performed during inspection, please record the details and save it for at least 3 years.

### ■ Cleaning

- Wipe off any dirt and stains using a soft cloth. To remove stubborn stains, wipe the area using a soft cloth moistened with neutral detergent.
- Do not apply compressed air. Dust may enter through gaps.
- Do not use petroleum solvents, since they will damage the coated surface.

## 7-2 Warranty

Check on the Oriental Motor Website for the product warranty.

## 7-3 Disposal

Dispose the product correctly in accordance with laws and regulations, or instructions of local governments.

# 8 Specifications

## 8-1 Product specifications

Model		OVR4048K5-V	OVR4068K5-V	OVR4088K5-V
Number of axes		4-axis		
Input voltage		24 VDC		
Maximum reach length	Vertical	570 mm (22.44 in.)	750 mm (29.53 in.)	900 mm (35.43 in.)
	Horizontal	480 mm (18.90 in.)	680 mm (26.77 in.)	880 mm (34.65 in.)
Payload		5 kg (11 lb.)		
Standard cycle time *1		0.7 sec		
Range of movement *2	S-axis (M1: swing)	±170 deg		
	L-axis (M2: lower arm)	-27 to +80 deg		
	U-axis (M3: upper arm)	-58 to +35 deg		
	R-axis (M4: wrist rotation)	±180 deg *3		
Repetitive positioning accuracy *4		±0.05 mm		
Permissible Load Inertia		0.069 kgm <sup>2</sup> (3800 oz-in <sup>2</sup> )		
Mass		16.5 kg (36.3 lb.)	17.4 kg (38.3 lb.)	26.9 kg (59.2 lb.)
Installation		Frame mounting		

Recommended power capacity: 24 VDC, 500 W

\*1 The time required to move a 1 kg (2.2 lb.) load back and forth between two points with a height of 25 mm (0.98 in.) and a width of 300 mm (11.81 in.). This is the cycle time when using the robot controller **MRC01**.

\*2 This is the range in which the robot can move in the ± direction based on the installation origin position (0 deg).

\*3 When using the robot controller **MRC01**, the range is ±170 deg.

\*4 Based on the specifications of each shaft reducer.

## 8-2 General specifications

Degree of protection		IP40 (Excluding connector part)
Operating environment	Ambient temperature	0 to +40 °C [+32 to +104 °F] (non-freezing)
	Humidity	85 % or less (non-condensing)
	Altitude	Up to 1,000 m (3,300 ft.) above sea level
	Surrounding atmosphere	No corrosive gas, dust, water or oil
Storage environment Shipping environment	Ambient temperature	-20 to +60 °C [-4 to 140 °F] (non-freezing)
	Humidity	85 % or less (non-condensing)
	Altitude	Up to 3,000 m (10,000 ft.) above sea level
	Surrounding atmosphere	No corrosive gas, dust, water or oil

8-3 Dimensions [Unit: mm (in.)]

■ OVR4048

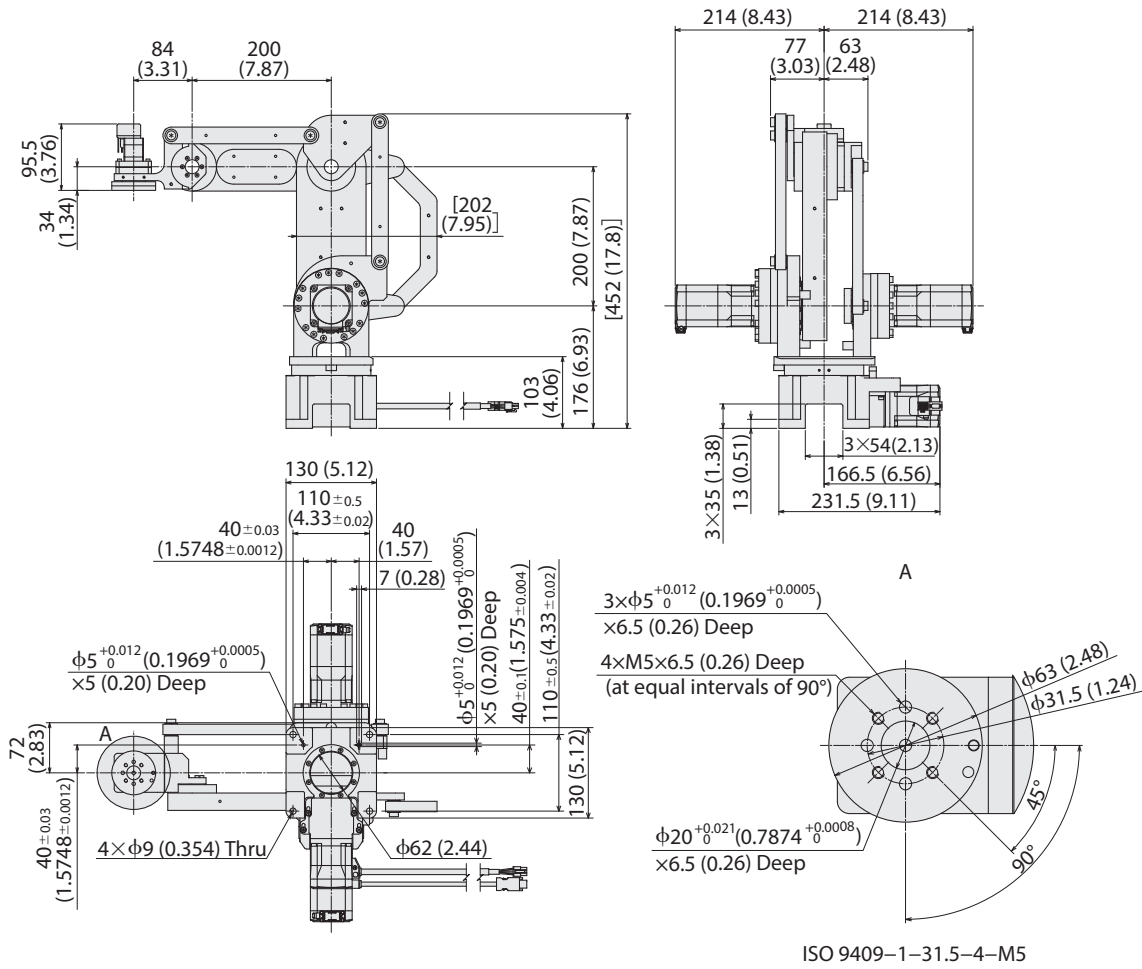

■ OVR4068

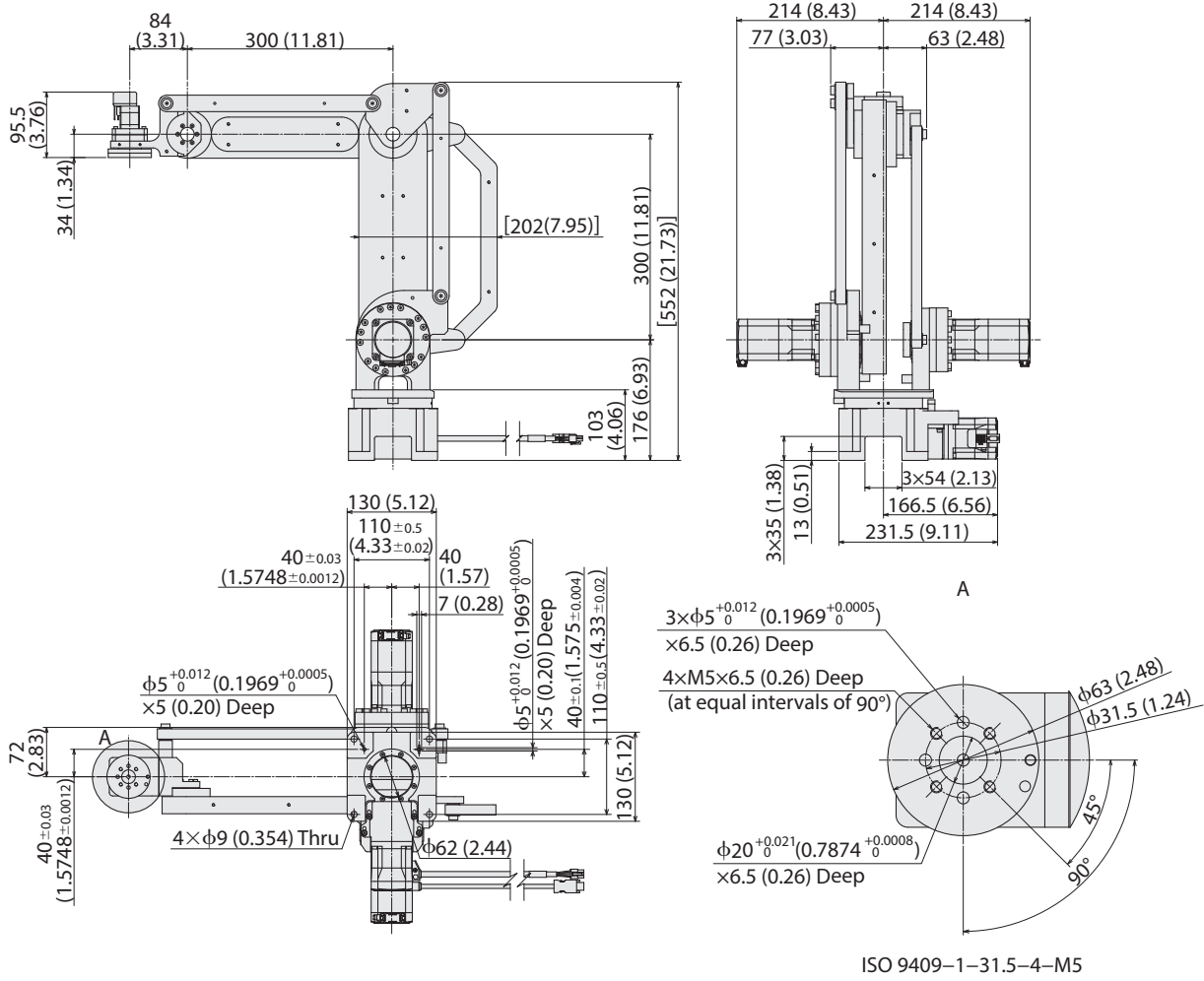

■ OVR4088

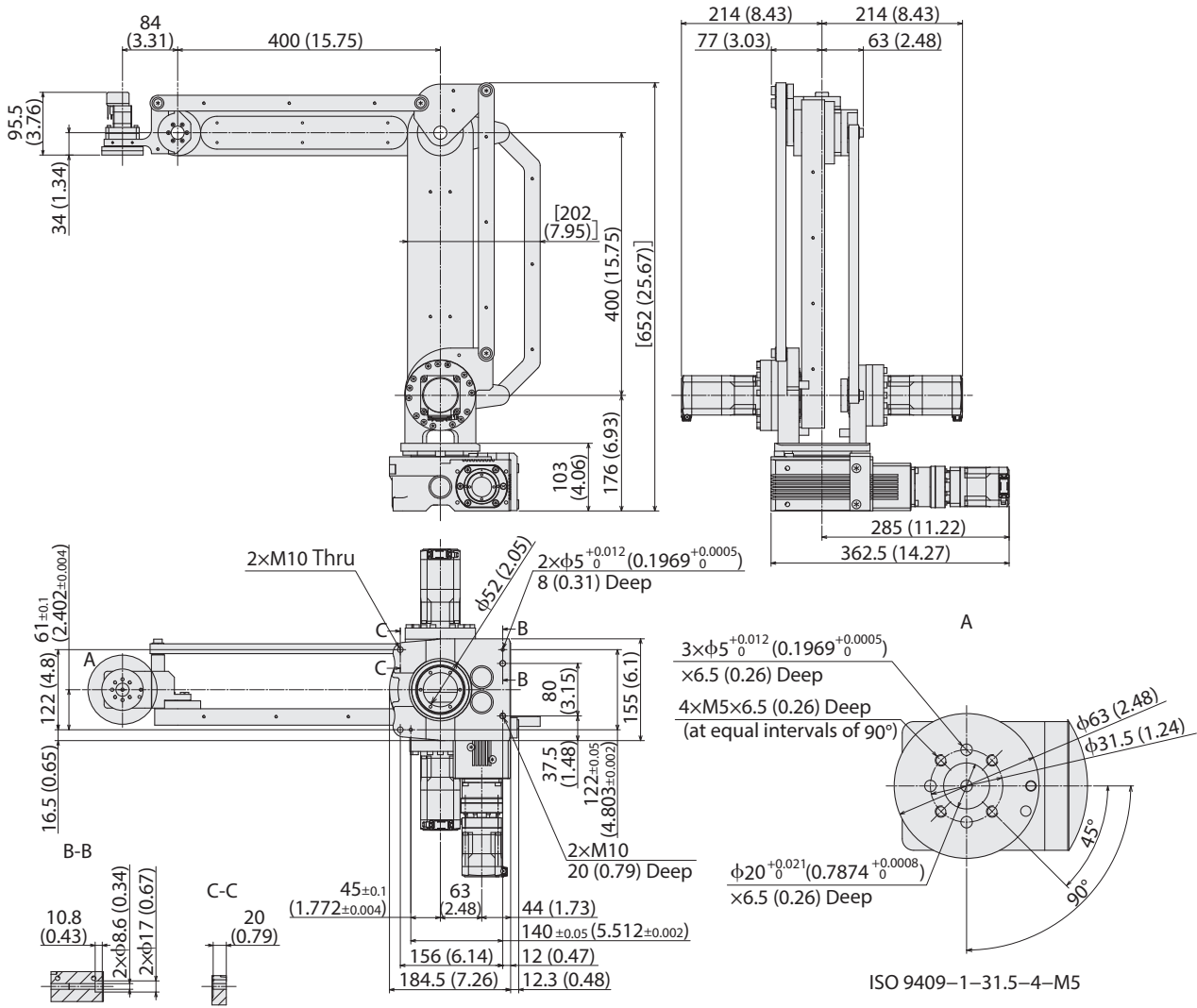

## 8-4 Operating range [Unit: mm (in.)]

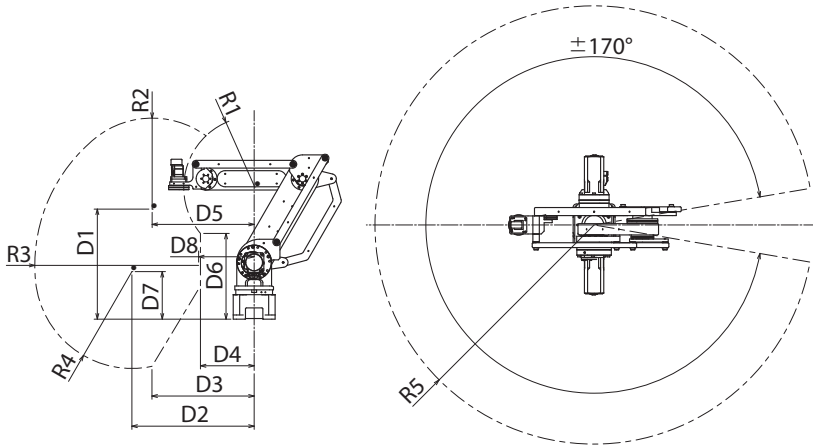

Model	R1	R2	R3	R4	R5	D1	D2	D3	D4	D5	D6	
<b>OVR4048K5-V</b>	203 (7.99)	229 (9.02)	382 (15.04)	232 (9.13)	480 (18.90)	234 (9.21)	255 (10.04)	190 (7.48)	149 (5.87)	225 (8.86)	199 (7.83)	
<b>OVR4068K5-V</b>	221 (8.70)	281 (11.06)	508 (20.00)	300 (11.81)	680 (26.77)	342 (13.46)	380 (14.96)	317 (12.48)	166 (6.54)	317 (12.48)	266 (10.47)	
<b>OVR4088K5-V</b>	278 (10.94)	386 (15.20)	483 (19.02)	386 (15.20)	880 (34.65)	280 (11.02)	498 (19.61)	496 (19.53)	156 (6.14)	473 (18.62)	194 (7.64)	
Model	D7	D8										
<b>OVR4048K5-V</b>	109 (4.29)	102 (4.02)										
<b>OVR4068K5-V</b>	148 (5.83)	172 (6.77)										
<b>OVR4088K5-V</b>	151 (5.94)	403 (15.87)										









- Unauthorized reproduction or copying of all or part of this document is prohibited. If a new copy is required to replace an original document that has been damaged or lost, please contact your nearest Oriental Motor sales office.
- Oriental Motor shall not be liable whatsoever for any problems relating to industrial property rights arising from use of any information, circuit, equipment or device provided or referenced in this document.
- Characteristics, specifications and dimensions are subject to change without notice.
- While we make every effort to offer accurate information in the document, we welcome your input. Should you find unclear descriptions, errors or omissions, please contact your nearest Oriental Motor sales office.
- **Orientalmotor** and ABZO sensor are registered trademarks or trademarks of Oriental Motor Co., Ltd., in Japan and other countries.

Other product names and company names mentioned in this document may be registered trademarks or trademarks of their respective companies and are hereby acknowledged. The third-party products mentioned in this document are recommended products, and references to their names shall not be construed as any form of performance guarantee. Oriental Motor is not liable whatsoever for the performance of these third-party products.

© Copyright ORIENTAL MOTOR CO., LTD. 2024

Published in July 2024

- Please contact your nearest Oriental Motor office for further information.

ORIENTAL MOTOR U.S.A. CORP.  
Technical Support Tel:800-468-3982  
8:30am EST to 5:00pm PST (M-F)

ORIENTAL MOTOR (EUROPA) GmbH  
Schiessstraße 44, 40549 Düsseldorf, Germany  
Technical Support Tel:00 800/22 55 66 22

ORIENTAL MOTOR (UK) LTD.  
Unit 5 Faraday Office Park, Rankine Road,  
Basingstoke, Hampshire RG24 8QB UK  
Tel:+44-1256347090

ORIENTAL MOTOR (FRANCE) SARL  
Tel:+33-1 47 86 97 50

ORIENTAL MOTOR ITALIA s.r.l.  
Tel:+39-02-93906347

ORIENTAL MOTOR ASIA PACIFIC PTE. LTD.  
Singapore  
Tel:1800-842-0280

ORIENTAL MOTOR (MALAYSIA) SDN. BHD.  
Tel:1800-806-161

ORIENTAL MOTOR (THAILAND) CO., LTD.  
Tel:1800-888-881

ORIENTAL MOTOR (INDIA) PVT. LTD.  
Tel:1800-120-1995 (For English)  
1800-121-4149 (For Hindi)

TAIWAN ORIENTAL MOTOR CO., LTD.  
Tel:0800-060708

SHANGHAI ORIENTAL MOTOR CO., LTD.  
Tel:400-820-6516

INA ORIENTAL MOTOR CO., LTD.  
Korea  
Tel:080-777-2042

ORIENTAL MOTOR CO., LTD.  
4-8-1 Higashiueno, Taito-ku, Tokyo  
110-8536 Japan  
Tel:+81-3-6744-0361  
[www.orientalmotor.co.jp/ja](http://www.orientalmotor.co.jp/ja)